

# Bourdon tube pressure switch

## Flameproof enclosure Ex d

### Models BA, BAX

WIKA data sheet PV 32.21



for further approvals, see page 5

## Process Performance Series

### Applications

- Pressure monitoring and control of processes
- Safety-critical applications in general process instrumentation, especially in the chemical and petrochemical industries, oil and gas industries, power generation incl. nuclear power plants, water/wastewater industries, mining
- For gaseous, liquid and aggressive media, also in aggressive ambience

### Special features

- No supply voltage needed for the switching of electrical loads
- Robust switch enclosure from 316L, IP66, NEMA 4X
- Setting ranges from 0 ... 2.5 bar up to 0 ... 1,000 bar, vacuum ranges
- Switch point repeatability < 0.5 %
- 1 or 2 independent set points, SPDT or DPDT, high switching power up to AC 250 V, 20 A



Bourdon tube pressure switch, model BA

### Description

These high-quality pressure switches have been developed especially for safety-critical applications. The high quality of the products and manufacturing in accordance with ISO 9001 ensure reliable monitoring of your plant. In production, the switches are traced by quality assurance software at every step and subsequently are 100 % tested. All wetted materials are from stainless steel as a standard.

In order to ensure as flexible operation as possible, the pressure switches are fitted with micro switches, which enable the switching of an electrical load of up to AC 250 V, 20 A directly. For lower switching power ratings, such as for PLC applications, argon gas-filled micro switches with gold-plated contacts can be selected.

Depending on the application, the appropriate variant for the contact version and the electrical connection can be selected; e.g. adjustable dead band instead of fixed dead band is often a feature necessary for control processes.

For applications with special requirements on the wetted parts, a version with Monel® is available.

By using a Bourdon tube measuring system, the model BA and BAX pressure switch is extremely robust and guarantees optimal operating characteristics and the highest measuring performances, with repeatability lower than 0.5 % of span.

For safety applications, the pressure switch is optionally available in a SIL 2-qualified or a SIL 3-qualified version.

# Specifications

Basic information	
Version	Bourdon tube pressure switch, flameproof enclosure Ex d
Special design feature	<ul style="list-style-type: none"> <li>■ For oxygen, oil- and grease-free</li> <li>■ Per NACE <sup>1)</sup> MR0175 / ISO 15156, use in H<sub>2</sub>S-containing environments in oil and gas production</li> <li>■ Per NACE <sup>1)</sup> MR0103 / ISO 17945, metals resistant to sulphide stress cracking</li> <li>■ Version for hydrogen (H<sub>2</sub>) applications</li> <li>■ Drying of wetted parts</li> <li>■ Offshore version</li> <li>■ Tropical version (suitable for environments with increased air humidity)</li> <li>■ Version for ammonia applications</li> <li>■ Geothermal version</li> <li>■ Low-temperature version to -60 °C</li> <li>■ Assembled as a diaphragm seal system</li> </ul>
Contact version	→ See table "Contact version"
Function	<ul style="list-style-type: none"> <li>■ 1 x SPDT (single pole double throw)</li> <li>■ 2 x SPDT (single pole double throw)</li> <li>■ 1 x DPDT (double pole double throw)</li> </ul> The DPDT function is realised with 2 simultaneously triggering SPDT microswitches, within 0.2 % of span.
Dead band	<ul style="list-style-type: none"> <li>■ 1 or 2 contacts with fixed dead band</li> <li>■ 1 or 2 contacts with adjustable dead band</li> <li>■ 1 contact with fixed dead band and 1 contact with adjustable dead band</li> </ul>
Dielectric strength	Safety class I (IEC 61298-2: 2008)
Switch enclosure	
Design	Housing cover can be secured against unauthorised access with screw locking. Laser-engraved product label from stainless steel.
Material	Aluminium alloy, copper-free, painted with acrylic paint
Mounting <sup>2)</sup>	<ul style="list-style-type: none"> <li>■ Direct mounting</li> <li>■ Mounting bracket for 2" pipe mounting from stainless steel AISI 304</li> <li>■ Wall mounting (only available for model BA)</li> <li>■ Wall bracket from stainless steel AISI 304 (only available for model BAX)</li> </ul>

1) General information about NACE standards; see data sheet IN 00.21  
 2) → See page 6 for permissible mounting positions

Contact version		Electrical rating (resistive load)	
		AC	DC
<b>With fixed dead band</b>			
UN	1 x SPDT, silver	250 V, 15 A	24 V, 2 A, 125 V, 0.5 A, 220 V, 0.25 A
US	1 x SPDT, silver, hermetically sealed, argon gas filling <sup>1)</sup>	250 V, 15 A	24 V, 2 A, 220 V, 0.5 A
UO	1 x SPDT, gold-plated, hermetically sealed, argon gas filling <sup>1)</sup>	125 V, 1 A	24 V, 0.5 A
UG	1 x SPDT, gold-plated	125 V, 1 A	24 V, 0.5 A
DN	2 x SPDT or 1 x DPDT, silver	250 V, 15 A	24 V, 2 A, 125 V, 0.5 A, 220 V, 0.25 A
DS	2 x SPDT or 1 x DPDT, silver, hermetically sealed, argon gas filling <sup>1)</sup>	250 V, 15 A	24 V, 2 A, 220 V, 0.5 A
DO	2 x SPDT, or 1 x DPDT gold-plated, hermetically sealed, argon gas filling <sup>1)</sup>	125 V, 1 A	24 V, 0.5 A
DG	2 x SPDT or 1 x DPDT, gold-plated	125 V, 1 A	24 V, 0.5 A
<b>With adjustable dead band</b>			
UR	1 x SPDT, silver	250 V, 20 A	24 V, 2 A, 220 V, 0.5 A
RR <sup>2)</sup>	2 x SPDT or 1 x DPDT, silver	250 V, 15 A	24 V, 2 A, 220 V, 0.5 A
<b>With fixed dead band and adjustable dead band</b>			
DR <sup>2)</sup>	2 x SPDT, silver (1 x UN + 1 x UR)	250 V, 15 A	24 V, 2 A, 220 V, 0.5 A

1) Permissible ambient temperature range: -30 ... +70 °C  
 2) Information on switching performance for this contact version on request

Accuracy specifications	
Set point repeatability	≤ 0.5 % of span of setting range
Dead band	→ See table "Setting range"

Setting range						
Model	Setting range (=working range)	Proof pressure in bar	Fixed dead band			Adjustable dead band 1 contact, UR in bar
	in bar		1 contact, UN, US, UO, UG in bar	2 contacts, DN, DS, DO, DG in bar		
		Model BA		Model BAX		
BA	-1 ... +1.5	4.5	≤ 0.15	≤ 0.30	-	0.35 ... 1.10
	-1 ... +5	12	≤ 0.20	≤ 0.30	-	0.55 ... 1.70
	-1 ... +15	30	≤ 0.30	≤ 0.40	-	1.40 ... 3.10
	0 ... 2.5	4.5	≤ 0.15	≤ 0.30	-	0.35 ... 1.10
	0 ... 6	12	≤ 0.20	≤ 0.30	-	0.55 ... 1.70
	0 ... 16	30	≤ 0.30	≤ 0.40	-	1.40 ... 3.10
BA, BAX	0 ... 40	75	≤ 0.80	≤ 0.70	≤ 1.2	2.10 ... 6.00
	0 ... 100	160	≤ 2	≤ 2	≤ 5	6 ... 17
	0 ... 160	210	≤ 3	≤ 3	≤ 7	13 ... 35
	0 ... 250	330	≤ 5	≤ 5	≤ 10	21 ... 65
	0 ... 400	480	≤ 8	≤ 8	≤ 12	26 ... 93
	0 ... 600	720	≤ 12	≤ 12	≤ 20	40 ... 115
BAX	0 ... 1,000 <sup>1)</sup>	1,200	≤ 20	-	≤ 50	75 ... 190

1) Wetted parts, bourdon tube: Inconel 718 (2.4668), process connection: Stainless steel AISI 316L

### Distance between set points

For versions with 2 x SPDT the distance between the set points must be > 5 % of the respective span.

### Set point adjustment

The set point can be specified by the customer or factory-set within the setting range.

After unscrewing the cover, set point adjustment can be made using the adjustment screw, which is fastened to the switch and thus secured against loss.

The set point (SP) and the switching direction need to be specified (e.g. SP1: 30 bar falling and SP2: 60 bar rising).

The set point is selectable within the entire setting range. For optimal performance we suggest to adjust the set point between 25 ... 75 % of the setting range. In the following example, the maximum possible setting range is shown to be dependent upon the switching direction.

### Example

Setting range: 0 ... 100 bar with one switch contact

Repeatability: 0.5 % of 100 bar = 0,5 bar

Dead band: ≤ 2 bar → See table "Setting range"

Non-settable range: 2 x repeatability + dead band = 2 x 0.5 bar + 2 bar = 3 bar

Rising pressure: Set point can be adjusted between 3 ... 100 bar

Falling pressure: Set point can be adjusted between 0 ... 97 bar

→ See operating instructions for further details.

Process connection	
<b>Standard</b>	<ul style="list-style-type: none"> <li>■ ANSI/ASME B1.20.1</li> <li>■ DIN EN ISO 228</li> </ul>
<b>Size</b>	
ANSI/ASME B1.20.1	<ul style="list-style-type: none"> <li>■ ¼ NPT, female thread</li> <li>■ ½ NPT, female thread via adapter</li> <li>■ ½ NPT, male thread via adapter</li> </ul>
DIN EN ISO 228	<ul style="list-style-type: none"> <li>■ G ¼, female thread via adapter</li> <li>■ G ½ A, male thread via adapter</li> <li>■ G ¼ A, male thread via adapter</li> </ul>
<b>Material (wetted)</b>	
Sensor element	Depending on the selected version
Process connection	→ See table "Wetted parts"





Other process connections on request

Wetted parts		
Version	Bourdon tube	Process connection
<b>Standard</b>	Stainless steel AISI 316L	
<b>Setting range: 0 ... 1,000 bar</b>	Stainless steel 17-4PH® (1.4542)	Stainless steel AISI 316L
<b>NACE</b> <b>Setting range: 0 ... 40 to 0 ... 400 bar</b>	Monel® 400	Stainless steel AISI 316L
<b>Monel®</b> <b>Setting range: 0 ... 40 to 0 ... 400 bar</b>	Monel® 400	







Electrical connection	
<b>Connection type</b>	<ul style="list-style-type: none"> <li>■ ½ NPT female (standard)</li> <li>■ ¾ NPT, Gk ½, Gk ¾, M20 x 1.5 female</li> <li>■ Cable gland non-armoured, Ex d, nickel-plated brass</li> <li>■ Cable gland non-armoured, Ex d, AISI 304</li> <li>■ Cable gland armoured, Ex d, nickel-plated brass</li> <li>■ Cable gland armoured, Ex d, AISI 304</li> </ul>
<b>Wire cross-section</b>	Use 0.5 ... 1.5 mm <sup>2</sup> (20 ... 16 AWG) for internal terminal block (also suitable for cable lugs). For the grounding cable connection to the protective conductor use max. 4 mm <sup>2</sup> for the internal and external screw.
<b>Pin assignment</b>	Connection details are given on the product label of the instrument. Connection terminals and the ground terminal are appropriately marked.

Operating conditions		
<b>Medium temperature range</b>	-40 ... +85 °C	
<b>Ambient temperature range</b>	T6/T85°C	T <sub>a</sub> -60 ... +60 °C
	T4/T135°C	T <sub>a</sub> -60 ... +85 °C
<b>Ingress protection of the complete instrument</b>	IP66 per EN/IEC 60529 (NEMA 4X)	
<b>Weight</b>	Approx. 2.4 kg for model BA Approx. 3.7 kg for model BAX	

## Approvals

Logo	Description	Region
 	<b>EU declaration of conformity</b>	European Union
	Pressure equipment directive PED, annex 1, category IV, safety accessories, module B + D	
	Low voltage directive	
	RoHS directive	
	ATEX directive <sup>1)</sup> II 1/2 GD (model BAX) II 2 GD (model BA)	
 	<b>IECEx <sup>1)</sup></b> Ex db IIC T6/T4 <sup>2)</sup> Ga/Gb, Ex tb IIIC T85/T135 <sup>2)</sup> Db (model BAX) Ex db IIC T6/T4 <sup>2)</sup> Gb, Ex tb IIIC T85/T135 <sup>2)</sup> Db (model BA)	International

### Optional approvals

Logo	Description	Region
	<b>UKCA</b>	United Kingdom
	Pressure equipment (safety) regulations	
	Electrical equipment designed for use within certain voltage limits in support of the electrical equipment (safety) regulations	
	Restriction of hazardous substances (RoHS) regulations	
	<b>EAC</b>	Eurasian Economic Community
	Hazardous areas <sup>1)</sup>	
	<b>Ex Ukraine</b> Hazardous areas <sup>1)</sup>	Ukraine
	<b>CCC</b> Hazardous areas <sup>1)</sup>	China
	<b>INMETRO</b> Hazardous areas <sup>1)</sup> (only available for model BA)	Brazil
	<b>KCs</b> Hazardous areas <sup>1)</sup>	South Korea
-	<b>ECAS</b> Hazardous areas <sup>1)</sup>	United Arab Emirates

<sup>1)</sup> Double marking ATEX and IECEx on the same product label. Country-specific Ex marking according to selected option.

<sup>2)</sup> The temperature class is related to the ambient temperature range

## Manufacturer's information and certificates

Logo	Description
	<b>SIL 3-capable (option)</b> Functional safety per IEC 61508 Contains performance level calculation per ISO 13849-1

### Certificates (option)

Certificates	
<b>Certificates</b>	<ul style="list-style-type: none"> <li>■ 2.2 test report per EN 10204 (e.g. state-of-the-art manufacturing, indication accuracy)</li> <li>■ 3.1 inspection certificate per EN 10204 (e.g. indication accuracy)</li> </ul>
<b>Recommended calibration interval</b>	1 year (dependent on conditions of use)

For approvals and certificates, see website

# Dimensions in mm [in]

## Model BA

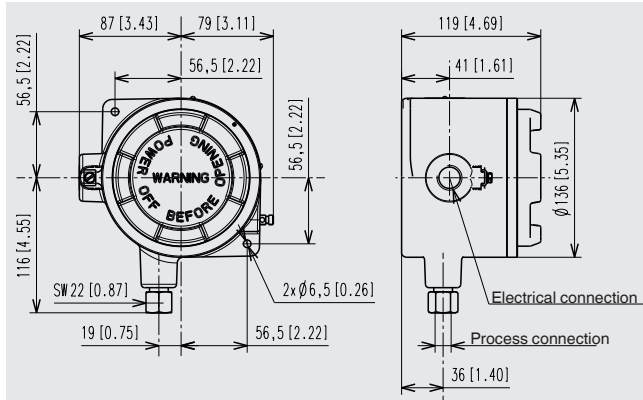

## Model BAX

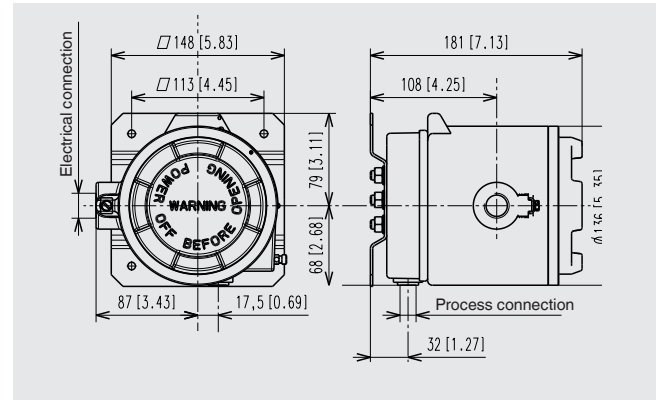

## Permissible mounting position

### Model BA

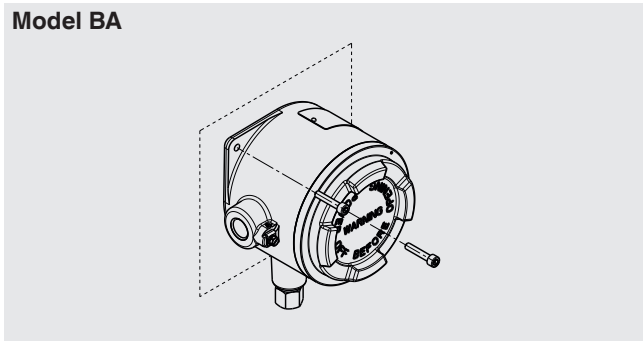

### Model BAX

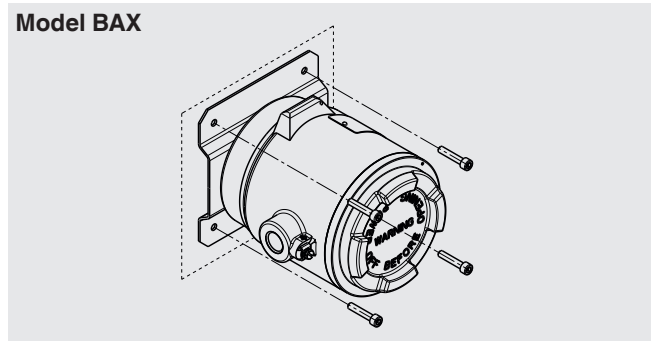

## Screw locking of the case cover

### Model BA

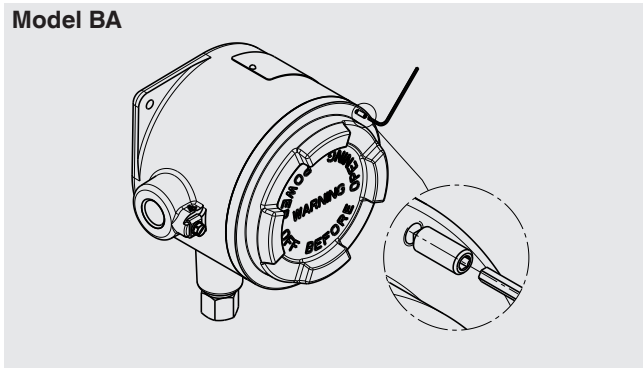



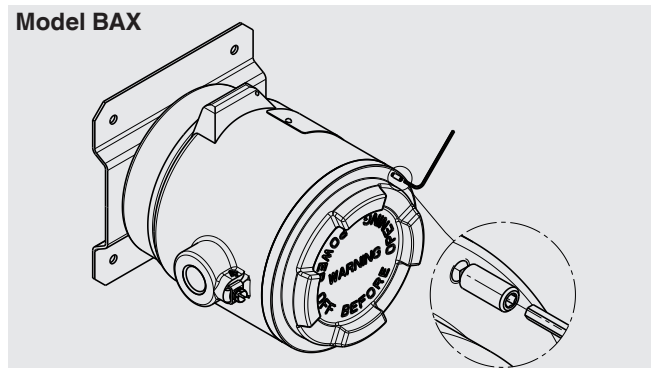

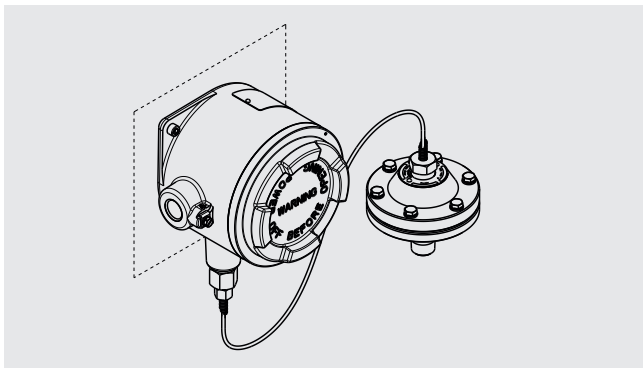

### Model BAX



## Diaphragm seal system example with model BA



## Accessories and spare parts

Model	Description
	<b>910.15</b> Syphons → See data sheet AC 09.06
	<b>910.13</b> Overpressure protector → See data sheet AC 09.04
	<b>IV10, IV11</b> Needle valve and multiport valve → See data sheet AC 09.22
	<b>IV20, IV21</b> Block-and-bleed valve → See data sheet AC 09.19
	<b>IVM</b> Monoflange, process and instrument version → See data sheet AC 09.17
	<b>BV</b> Ball valve, process and instrument version → See data sheet AC 09.28

### Ordering information

Model / Unit / Setting range of set point / Contact version / Process connection / Electrical connection / Wetted parts / Options

© 12/2010 WIKA Alexander Wiegand SE & Co. KG, all rights reserved.  
 The specifications given in this document represent the state of engineering at the time of publishing.  
 We reserve the right to make modifications to the specifications and materials.  
 In case of a different interpretation of the translated and the English data sheet, the English wording shall prevail.