

# Technical Information

## Deltabar S

### PMD75, FMD77, FMD78

Differential pressure measurement and pressure measurement

Differential pressure transmitter with metal sensors



#### Applications

The device is used for the following measuring tasks:

- Flow measurement (volume flow or mass flow) in conjunction with differential pressure sensors in gases, vapors and liquids
- Level, volume or mass measurements in liquids
- High process temperatures up to 400 °C (752 °F) possible with diaphragm seal mount
- Differential pressure monitoring, e.g. of filters and pumps

#### Your benefits

- Very good reproducibility and long-term stability
- High reference accuracy up to 0.035 %
- Turn down up to 100:1, higher on request
- Used for flow and differential pressure monitoring up to SIL3, certified to IEC 61508 by TÜV SÜD
- High level of safety during operation thanks to function monitoring from the measuring cell to the electronics
- The patented TempC Membrane for the diaphragm seal reduces measured errors caused by environmental and process temperature influences to a minimum
- Easy electronics replacement guaranteed with HistoROM®/M-DAT
- Cost-effective installation with Deltabar S FMD77, capillary on low-pressure side

## Table of contents

<b>About this document</b> . . . . .	<b>4</b>	<b>Installation</b> . . . . .	<b>34</b>
Document function . . . . .	4	General installation instructions . . . . .	34
Symbols used . . . . .	4	Measuring arrangement . . . . .	34
Documentation . . . . .	5	Measuring arrangement for devices with diaphragm seals – FMD77 and FMD78 . . . . .	34
Terms and abbreviations . . . . .	6	Orientation . . . . .	34
Turn down calculation . . . . .	7	Wall and pipe mounting, transmitter (optional) . . . . .	35
Registered trademarks . . . . .	7	Wall and pipe mounting, valve manifold (optional) . . . . .	35
<b>Function and system design</b> . . . . .	<b>8</b>	"Separate housing" version . . . . .	36
Device features . . . . .	8	Turning the housing . . . . .	37
Measuring principle . . . . .	10	<b>Environment</b> . . . . .	<b>38</b>
Product design . . . . .	10	Ambient temperature range . . . . .	38
Communication protocol . . . . .	11	Storage temperature range . . . . .	39
<b>Input</b> . . . . .	<b>12</b>	Degree of protection . . . . .	39
Measured variable . . . . .	12	Climate class . . . . .	39
Measuring range . . . . .	12	Electromagnetic compatibility . . . . .	39
<b>Output</b> . . . . .	<b>14</b>	Vibration resistance . . . . .	39
Output signal . . . . .	14	Oxygen applications . . . . .	40
Signal range . . . . .	14	Ultrapure gas applications . . . . .	40
Signal on alarm . . . . .	14	Hydrogen applications . . . . .	40
Load . . . . .	14	Operation in very corrosive environment . . . . .	40
Damping . . . . .	15	<b>Process</b> . . . . .	<b>41</b>
Alarm current . . . . .	15	Process temperature limits (temperature at transmitter) . . . . .	41
Firmware version . . . . .	15	Process temperature limits of capillary armoring: FMD77 and FMD78 . . . . .	43
Protocol-specific data HART . . . . .	16	Process temperature range, seals . . . . .	44
Wireless HART data . . . . .	16	Pressure specifications . . . . .	45
Protocol-specific data PROFIBUS PA . . . . .	16	<b>Mechanical construction</b> . . . . .	<b>46</b>
Protocol-specific data FOUNDATION Fieldbus . . . . .	17	Device height . . . . .	46
<b>Power supply</b> . . . . .	<b>20</b>	T14 housing, optional display on the side . . . . .	47
Terminal assignment . . . . .	20	T15 housing, optional display on the top . . . . .	48
Supply voltage . . . . .	21	T17 housing (hygienic), optional display on the side . . . . .	48
Current consumption . . . . .	21	Process connections PMD75 . . . . .	49
Electrical connection . . . . .	21	Process connections PMD75 . . . . .	50
Terminals . . . . .	21	Process connections PMD75 . . . . .	51
Cable entries . . . . .	22	Valve manifold DA63M- (optional) . . . . .	52
Device plugs . . . . .	22	FMD77: Selecting the process connection and capillary line . . . . .	53
Cable specification . . . . .	23	FMD77 - Overview . . . . .	54
Start-up current . . . . .	23	Process connections FMD77 with diaphragm seal, high- pressure side . . . . .	55
Residual ripple . . . . .	23	Process connections FMD77 with diaphragm seal, high- pressure side . . . . .	56
Overtoltage protection (optionally for HART, PROFIBUS PA and FOUNDATION Fieldbus) . . . . .	23	Process connections FMD77 with diaphragm seal . . . . .	57
Influence of power supply . . . . .	23	Process connections FMD77 with diaphragm seal . . . . .	59
<b>Performance characteristics</b> . . . . .	<b>24</b>	Process connections FMD77 with diaphragm seal . . . . .	61
Response time . . . . .	24	Process connections FMD77 with diaphragm seal, low- pressure side . . . . .	61
Reference operating conditions . . . . .	24	FMD78: Selecting the process connection and capillary line . . . . .	62
Maximum measured error (total performance) . . . . .	24	FMD78 basic device . . . . .	63
Resolution . . . . .	28	Process connections FMD78 with diaphragm seal . . . . .	64
Total error . . . . .	28	Process connections FMD78 with diaphragm seal . . . . .	65
Long-term stability . . . . .	29	Process connections FMD78 with diaphragm seal . . . . .	68
Response time T63 and T90 . . . . .	30	Process connections FMD78 with diaphragm seal . . . . .	70
Installation factors . . . . .	32		





Process connections FMD78 with diaphragm seal . . . . .	71	Welding flanges and weld-in adapters . . . . .	113
Process connections FMD78 with diaphragm seal . . . . .	73	Manifolds . . . . .	113
Process connections FMD78 with diaphragm seal . . . . .	74	Additional mechanical accessories . . . . .	113
Process connections FMD78 with diaphragm seal . . . . .	75	Service-specific accessories . . . . .	113
Separate housing: Wall and pipe mounting with mounting bracket . . . . .	77	<b>Supplementary documentation . . . . .</b>	<b>114</b>
Flushing rings . . . . .	78	Field of Activities . . . . .	114
Weight . . . . .	78	Technical Information . . . . .	114
Materials not in contact with process . . . . .	79	Special Documentation . . . . .	114
Materials in contact with process . . . . .	83	Operating Instructions . . . . .	114
Fill fluid . . . . .	85	Brief Operating Instructions . . . . .	114
<b>Operability . . . . .</b>	<b>88</b>	Brief Operating Instructions . . . . .	114
Operating concept . . . . .	88	Functional safety manual (SIL) . . . . .	114
Local operation . . . . .	88	Overfill prevention . . . . .	114
Remote operation . . . . .	91	Safety Instructions (XA) . . . . .	114
HistoROM®/M-DAT (optional) . . . . .	93	Installation/Control Drawings . . . . .	115
System integration . . . . .	93		
<b>Planning instructions for diaphragm seal systems . . . . .</b>	<b>94</b>		
Applications . . . . .	94		
Function and design . . . . .	95		
Differential pressure transmitter . . . . .	96		
Diaphragm seal filling oils . . . . .	97		
Operating temperature range . . . . .	97		
Response time . . . . .	98		
Cleaning instructions . . . . .	98		
Installation instructions . . . . .	98		
Vacuum applications . . . . .	102		
<b>Certificates and approvals . . . . .</b>	<b>103</b>		
CE mark . . . . .	103		
RCM-Tick marking . . . . .	103		
Ex approvals . . . . .	103		
EAC conformity . . . . .	103		
Suitable for hygiene applications . . . . .	103		
Certificate of current Good Manufacturing Practices (cGMP) . . . . .	104		
Functional safety SIL/ IEC 61508 Declaration of Conformity (optional) . . . . .	104		
Overfill prevention . . . . .	104		
CRN approval . . . . .	104		
Other standards and guidelines . . . . .	104		
Pressure Equipment Directive 2014/68/EU (PED) . . . . .	105		
Manufacturer declarations . . . . .	105		
Marine approval . . . . .	105		
Classification of process sealing between electrical systems and (flammable or combustible) process fluids in accordance with ANSI/ISA 12.27.01 . . . . .	106		
Inspection certificate . . . . .	106		
Calibration . . . . .	106		
Service . . . . .	107		
<b>Ordering information . . . . .</b>	<b>108</b>		
Special device versions . . . . .	108		
Scope of delivery . . . . .	108		
Measuring point (TAG) . . . . .	108		
Configuration data sheet . . . . .	109		
<b>Accessories . . . . .</b>	<b>113</b>		
HistoROM®/M-DAT . . . . .	113		

## About this document



<b>Document function</b>	The document contains all the technical data on the device and provides an overview of the accessories and other products that can be ordered for the device.
--------------------------	---

### Symbols used









#### Safety symbols

Symbol	Meaning
	<b>DANGER!</b> This symbol alerts you to a dangerous situation. Failure to avoid this situation will result in serious or fatal injury.
	<b>WARNING!</b> This symbol alerts you to a dangerous situation. Failure to avoid this situation can result in serious or fatal injury.
	<b>CAUTION!</b> This symbol alerts you to a dangerous situation. Failure to avoid this situation can result in minor or medium injury.
	<b>NOTICE!</b> This symbol contains information on procedures and other facts which do not result in personal injury.

#### Electrical symbols

Symbol	Meaning	Symbol	Meaning
	<b>Protective ground connection</b> A terminal which must be connected to ground prior to establishing any other connections.		<b>Ground connection</b> A grounded terminal which, as far as the operator is concerned, is grounded via a grounding system.

#### Symbols for certain types of information

Symbol	Meaning
	<b>Permitted</b> Procedures, processes or actions that are permitted.
	<b>Preferred</b> Procedures, processes or actions that are preferred.
	<b>Forbidden</b> Procedures, processes or actions that are forbidden.
	<b>Tip</b> Indicates additional information.
	Reference to documentation
	Reference to page
	Reference to graphic
	Visual inspection

### Symbols in graphics

Symbol	Meaning
1, 2, 3 ...	Item numbers
1., 2., 3. ...	Series of steps
A, B, C, ...	Views
A-A, B-B, C-C, ...	Sections

---

### Documentation

See the "Supplementary documentation" section →  114



The document types listed are available:

In the Download Area of the Endress+Hauser Internet site: [www.endress.com](http://www.endress.com) → Download

### Safety Instructions (XA)

See the "Safety instructions" section →  114

Terms and abbreviations

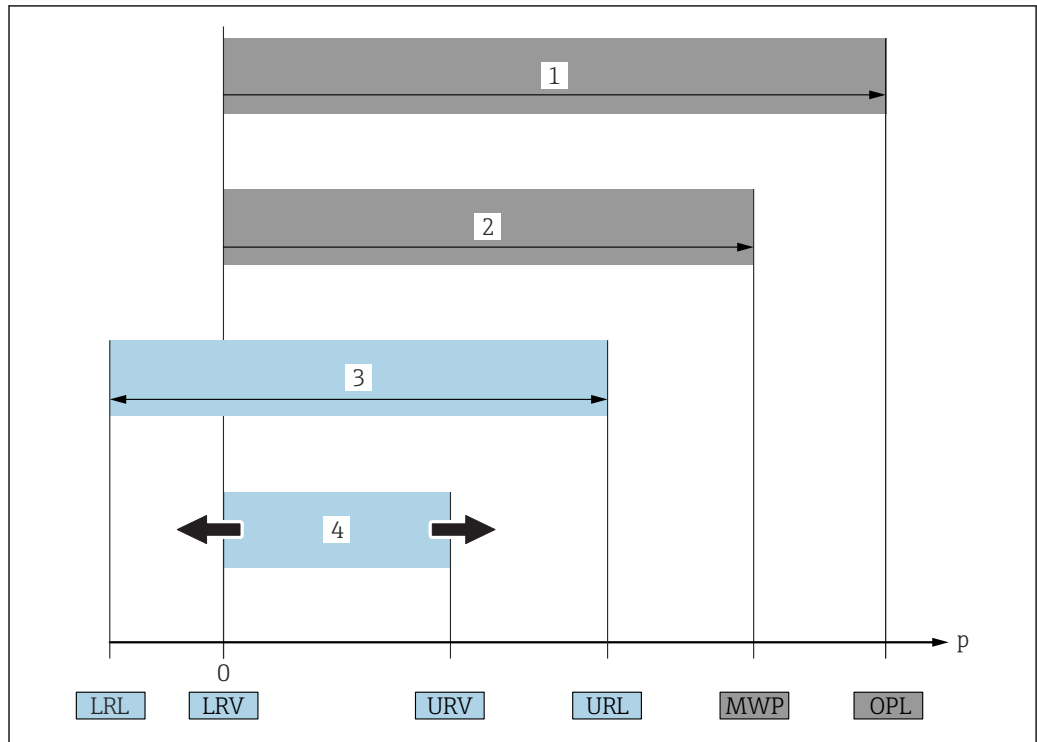

A0029505

Item	Term/abbreviation	Explanation
1	OPL	The OPL (over pressure limit = sensor overload limit) for the measuring device depends on the lowest-rated element, with regard to pressure, of the selected components, i.e. the process connection has to be taken into consideration in addition to the measuring cell. Also observe pressure-temperature dependency. For the relevant standards and additional notes see the "Pressure specifications" section → 45. The OPL may only be applied for a limited period of time.
2	MWP	The MWP (maximum working pressure) for the sensors depends on the lowest-rated element, with regard to pressure, of the selected components, i.e. the process connection has to be taken into consideration in addition to the measuring cell. Also observe pressure-temperature dependency. For the relevant standards and additional notes see the "Pressure specifications" section → 45. The MWP may be applied at the device for an unlimited period. The MWP can also be found on the nameplate.
3	Maximum sensor measuring range	Span between LRL and URL This sensor measuring range is equivalent to the maximum calibratable/adjustable span.
4	Calibrated/adjusted span	Span between LRV and URV Factory setting: 0 to URL Other calibrated spans can be ordered as customized spans.
p	-	Pressure
-	LRL	Lower range limit
-	URL	Upper range limit
-	LRV	Lower range value
-	URV	Upper range value
-	TD (Turn down)	Turn down Example - see the following section.

**Turn down calculation**

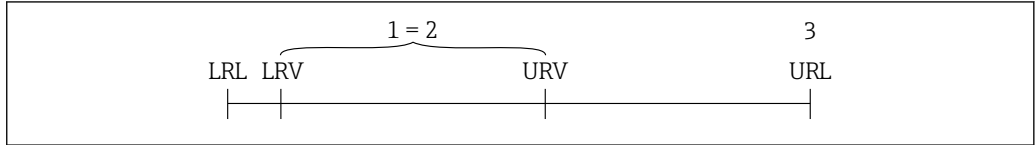

A0029545

- 1 Calibrated/adjusted span
- 2 Zero point-based span
- 3 URL sensor

**Example**

- Sensor: 10 bar (150 psi)
- Upper range value (URL) = 10 bar (150 psi)
- Calibrated/adjusted span: 0 to 5 bar (0 to 75 psi)
- Lower range value (LRV) = 0 bar (0 psi)
- Upper range value (URV) = 5 bar (75 psi)

Turn down (TD):

$$TD = \frac{URL}{|URV - LRV|}$$

$$TD = \frac{10 \text{ bar (150 psi)}}{|5 \text{ bar (75 psi)} - 0 \text{ bar (0 psi)}|} = 2$$

In this example, the TD is 2:1.  
This span is based on the zero point.

**Registered trademarks**

**HART®**

Registered trademark of the FieldComm Group, Austin, USA

**PROFIBUS®**

Registered trademark of the PROFIBUS User Organization, Karlsruhe, Germany

**FOUNDATION™Fieldbus**

Registered trademark of the FieldComm Group, Austin, Texas, USA

## Function and system design

### Device features

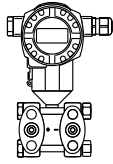
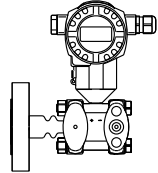
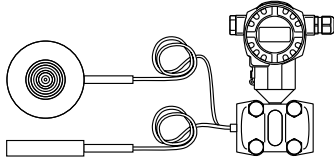
 <p>PMD75</p>	<p>A0023922</p>
 <p>FMD77 with mounted diaphragm seal</p>	<p>A0023923</p>
 <p>FMD78 with capillary diaphragm seals</p>	<p>A0023924</p>

### Field of application

PMD75:

- Flow
- Level
- Differential pressure
- Pressure

FMD77:

- Level
- Differential pressure

FMD78:

- Level
- Differential pressure

### Process connections

PMD75:

- 1/4 - 18 NPT
- RC 1/4

FMD77 low-pressure side (-):

- 1/4 - 18 NPT
- RC 1/4
- Alternatively available with capillary and diaphragm seal

FMD77 high-pressure side (+):

- EN DN 50 - DN 100
- ASME NPS 2" - 4"
- JIS 80A - 100A

FMD78:

Wide range of diaphragm seals

### Measuring ranges

- PMD75: from -10 to +10 mbar (-0.15 to +0.15 psi) to -40 to +40 bar (-600 to +600 psi)  
As gauge or absolute pressure sensor: up to 250 bar (3750 psi)
- FMD77: from -100 to +100 mbar (-1.5 to +1.5 psi) to -16 bar to +16 bar (-240 to +240 psi)
- FMD78: from -100 to +100 mbar (-1.5 to +1.5 psi) to -40 to +40 bar (-600 to +600 psi)

### OPL

PMD75:

on one side: up to 420 bar (6 300 psi)

on both sides: up to 630 bar (9 450 psi)

As gauge or absolute pressure sensor: up to 375 bar (5625 psi)

FMD77:

on one side: up to 160 bar (2 400 psi)

on both sides: up to 240 bar (3 600 psi)

FMD78:

on one side: up to 160 bar (2 400 psi)

on both sides: up to 240 bar (3 600 psi)

### Process temperature range (temperature at process connection)

PMD75:

-50 to +85 °C (-58 to +185 °F)

-50 to +110 °C (-58 to +230 °F) at valve manifold (→  41)

FMD77:

-70 to +400 °C (-94 to +752 °F)

(depending on the filling oil)

FMD78:

-70 to +400 °C (-94 to +752 °F)

(depending on the filling oil)

### Ambient temperature range

- Without LCD display: up to -54 to +85 °C (-65 to +185 °F)
- With LCD display: -20 to +70 °C (-4 to +158 °F)  
(extended temperature application range -50 to +85 °C (-58 to +185 °F) with limitations in optical properties, such as display speed and contrast)
- Separate housing: -20 to +60 °C (-4 to +140 °F)
- Diaphragm seal systems depending on the version

### Reference accuracy

- PMD75: up to ±0.035 % of the set span
- FMD77: up to ±0.075 % of the set span
- FMD78: up to ±0.075 % of the set span

### Supply voltage

Supply voltage non-Ex

■ 4 to 20 mA HART: 10.5 to 45 V DC

■ PROFIBUS PA and FOUNDATION Fieldbus: 9 to 32 V DC

Supply voltage Ex ia

10.5 to 30 V DC

### Output

4 to 20 mA with superimposed HART protocol, PROFIBUS PA or FOUNDATION Fieldbus

### Options

- HistoROM®/M-DAT memory chip
- PMD75: with blind flange on LP side for gauge and absolute pressure measurement

**Specialties**

PMD75:

- $p_{\text{stat}}$  up to 420 bar (6 300 psi)
- Process isolating diaphragm: tantalum

FMD77:

For high medium temperatures

FMD78:

For high medium temperatures

Wide range of diaphragm seals

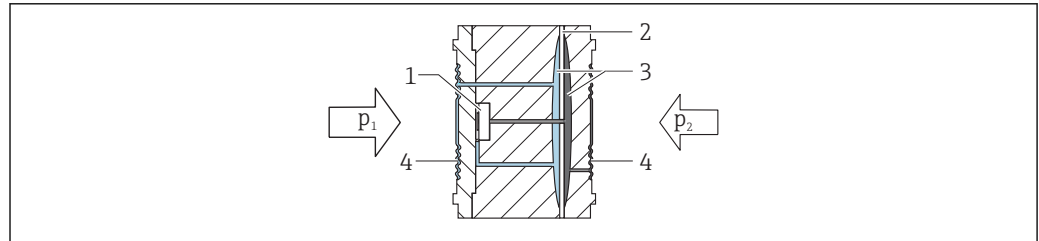
**Measuring principle****Metal process isolating diaphragm**

A0023919

- 1 Measuring element
- 2 Middle diaphragm
- 3 Filling oil
- 4 Process isolating diaphragm

The process isolating diaphragms are deflected on both sides by the acting pressures. A filling oil transfers the pressure to a resistance bridge (semiconductor technology). The change in the bridge output voltage, which depends on the differential pressure, is measured and processed

**Advantages:**

- Standard system pressures: 160 bar (2 400 psi) up to 420 bar (6 300 psi)
- High long-term stability
- Very high single-sided overload resistance

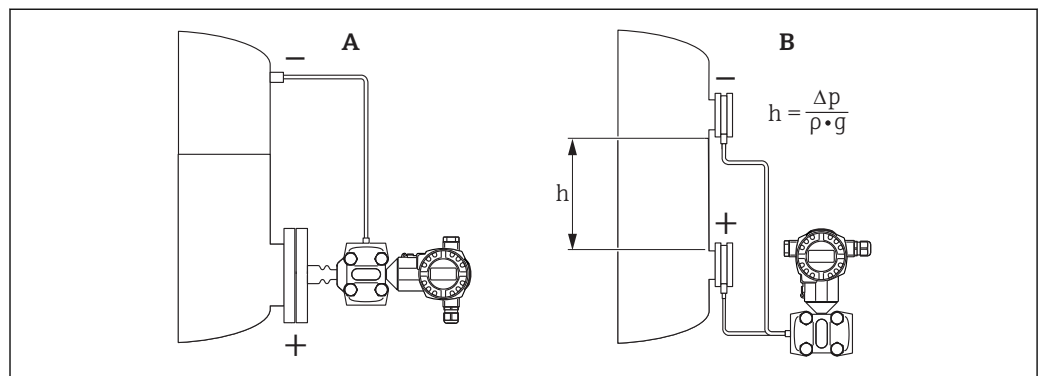
**Product design****Level measurement (level, volume and mass):**

A0023921

- Level measurement with FMD77
  - Level measurement with FMD78
- $h$  Height (level)  
 $\Delta p$  Differential pressure  
 $\rho$  Density of the medium  
 $g$  Gravitation constant

*Your benefits*

- Selection of the level operating mode which is optimum for your application in the device software
- Volume and mass measurements in any vessel shape by means of a freely programmable characteristic curve
- Choice of diverse level units with automatic unit conversion
- A customized unit can be specified.
- Has a wide range of uses, e.g.
  - for level measurement in vessels with pressure overlay
  - for foam formation
  - in vessels with agitators or screen fittings
  - for liquid gases
  - for standard level measurement

**Flow measurement**

Flow measurement with Deltabar S and primary device:

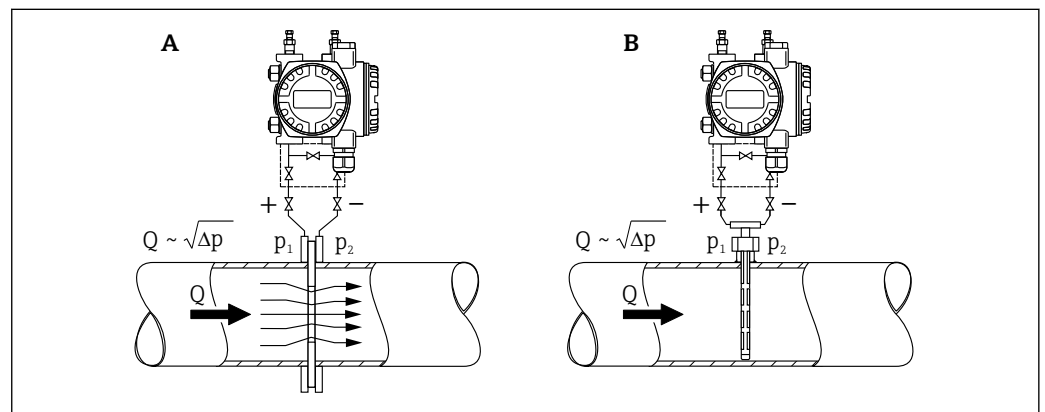

A0023920

- A Orifice plate
- B Pitot tube
- Q Flow
- $\Delta p$  Differential pressure,  $\Delta p = p_1 - p_2$

*Your benefits*

- Choice of four flow modes of operation: volume flow, corrected volume flow (European norm conditions), standard volume flow (American standard conditions) and mass flow
- Choice of diverse flow units with automatic unit conversion.
- A customized unit can be specified.
- Low flow cut off: when activated, this function suppresses small flows which can lead to large fluctuations in the measured value.
- Contains two totalizers as standard. One totalizer can be reset to zero.
- The totalizing mode and unit can be individually set for each totalizer. This allows independent daily and annual quantity totalizing.

**Communication protocol**

- 4 to 20 mA with HART communication protocol
- PROFIBUS PA
  - Endress+Hauser devices meet the requirements specified by the FISCO model.
  - Due to a low current consumption of  $13 \text{ mA} \pm 1 \text{ mA}$ , the following number of devices can be operated on one bus segment if installing as per FISCO: up to 7 devices for Ex ia, CSA IS and FM IS applications or up to 27 devices for all other applications e.g. in non-hazardous areas, Ex nA etc. Further information on PROFIBUS PA can be found in Operating Instructions BA00034S "PROFIBUS DP/PA: Guidelines for planning and commissioning" and in the PNO Guideline.
- FOUNDATION Fieldbus
  - Endress+Hauser devices meet the requirements specified by the FISCO model.
  - Due to a low current consumption of  $15.5 \text{ mA} \pm 1 \text{ mA}$ , the following number of devices can be operated on one bus segment if installing as per FISCO: up to 6 devices for Ex ia, CSA IS and FM IS applications or up to 24 devices for all other applications e.g. in non-hazardous areas, Ex nA etc. Further information on FOUNDATION Fieldbus, such as requirements for bus system components, can be found in Operating Instructions BA00013S "FOUNDATION Fieldbus Overview".

## Input

### Measured variable

### Measured process variables

Differential pressure, pressure

### Calculated process variables

- Flow rate (volume flow or mass flow)
- Absolute pressure, gauge pressure
- Level (level, volume or mass)

### Measuring range

Sensor	Maximum sensor measuring range		Smallest calibratable span <sup>1)</sup>	MWP	OPL		Min. operating pressure <sup>2)</sup>	Option <sup>3)</sup>
	lower (LRL)	upper (URL)			on one side	on both sides		
[mbar (psi)]	[mbar (psi)]	[mbar (psi)]	[mbar (psi)]	[bar (psi)]	[bar (psi)]	[bar (psi)]	[mbar <sub>abs</sub> (psi <sub>abs</sub> )]	PN 160
<b>FMD77, FMD78, PMD75: Option PN 160 / 16 MPa / 2400 psi</b>								
10 (0.15) (PMD75 only)	-10 (-0.15)	+10 (+0.15)	0.25 (0.00375)	160 (2400)	160 (2400)	240 (3600)	0.1 (0.0015)	7B
30 (0.45) (PMD75 only)	-30 (-0.45)	+30 (+0.45)	0.3 (0.0045)	160 (2400) <sup>5)</sup>	160 (2400)	240 (3600)		7C
100 (1.5)	-100 (-1.5)	+100 (+1.5)	1/5 (0.015/0.075) <sup>4)</sup>					7D
500 (7.5)	-500 (-7.5)	+500 (+7.5)	5 (0.075)					7F
3000 (45)	-3000 (-45)	+3000 (+45)	30 (0.45)					7H
16000 (240)	-16000 (-240)	+16000 (+240)	160 (2.4)					7L
40000 (600)	-40000 (-600)	+40000 (+600)	400 (6)	160 (2400) <sup>5) 6)</sup>	"+" side <sup>7)</sup> : 160 (2400)	7M		
<b>PMD75: Option PN 420 / 42 MPa / 6300 psi</b>								
100 (1.5)	-100 (-1.5)	+100 (+1.5)	1/5 (0.015/0.075) <sup>4)</sup>	420 (6300) <sup>5)</sup>	420 (6300)	630 (9450)	0.1 (0.0015)	8D
500 (7.5)	-500 (-7.5)	+500 (+7.5)	5 (0.075)	420 (6300) <sup>5) 6)</sup>	420 (6300)	630 (9450)		8F
3000 (45)	-3000 (-45)	+3000 (+45)	30 (0.45)					8H
16000 (240)	-16000 (-240)	+16000 (+240)	160 (2.4)					8L
40000 (600)	-40000 (-600)	+40000 (+600)	400 (6)					"+" side <sup>7)</sup> : 420 (6300)

1) Turn down > 100:1 on request

2) The minimum operating pressure indicated in the table applies to silicone oil under reference operating conditions. Min. operating pressure at 85 °C (185 °F) for silicone oil: up to 10 mbar<sub>abs</sub> (0.15 psi<sub>abs</sub>). FMD77 and FMD78: Min. operating pressure: 50 mbar<sub>abs</sub> (0.75 psi<sub>abs</sub>); observe also the pressure and temperature application limits of the selected filling oil → 102. For vacuum applications, follow the installation instructions → 102.

3) Product Configurator, order code for "Nominal range; PN"

4) Smallest calibratable span for the PMD75: 1 mbar (0.015 psi); Smallest calibratable span for the FMD77 and FMD78: 5 mbar (0.075 psi)

5) All PMD75 process connections are CRN-approved. If O-rings are used, the MWP is 315 bar (4 725 psi); if PTFE and CU seals are used, the MWP is 120 bar (1 800 psi).

6) If pressure is applied on the negative side only, the MWP is 100 bar (1 500 psi).

7) "-" side: 100 bar (1 500 psi)

Sensor	Maximum sensor measuring range		Smallest calibratable span	MWP	OPL		Min. operating pressure <sup>1)</sup>	Option <sup>2)</sup>
	lower (LRL)	upper (URL)			on one side	on both sides		
bar (psi)	bar (psi)	bar (psi)	bar (psi)	bar (psi)	bar (psi)		mbar <sub>abs</sub> (psi <sub>abs</sub> )	
<b>PMD75: optionally available as a gauge or absolute pressure sensor</b>								
160 (2400) rel	-1 (-15)	160 (2400)	40 (600)	160 (2400)	240 (3600)	- <sup>3)</sup>	10	7Q
160 (2400) abs	0	160 (2400)	4 (60)	160 (2400)	240 (3600)	- <sup>3)</sup>	10	7V
250 (3750) rel	-1 (-15)	250 (3750)	40 (600)	250 (3750)	375 (5625)	- <sup>3)</sup>	10	7R <sup>4)</sup>
250 (3750) abs	0	250 (3750)	4 (60)	250 (3750)	375 (5625)	- <sup>3)</sup>	10	7W <sup>4)</sup>

- 1) The minimum operating pressure indicated in the table applies to silicone oil under reference operating conditions. Min. operating pressure at 85 °C (185 °F) for silicone oil: up to 10 mbar<sub>abs</sub> (0.15 psi<sub>abs</sub>).
- 2) Product Configurator, order code for "Nominal range; PN"
- 3) Available only with blind flange on LP side.
- 4) The 250 bar sensor can be used over the entire measuring range with up to 100,000 load changes without specification restrictions.

## Output

### Output signal

- 4 to 20 mA with superimposed digital communication protocol HART, 2-wire
- Digital communication signal PROFIBUS PA (Profile 3.0), 2-wire
  - Signal coding: Manchester Bus Powered (MBP): Manchester II
  - Transmission rate: 31.25 KBit/s voltage mode
- Digital communication signal FOUNDATION Fieldbus, 2-wire
  - Signal coding: Manchester Bus Powered (MBP): Manchester II
  - Transmission rate: 31.25 KBit/s voltage mode

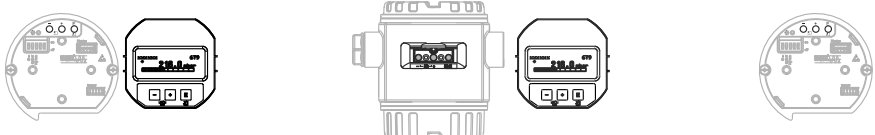
Output	Internal + LCD	External + LCD	Internal
			
	Option <sup>1)</sup>		
4 to 20mA HART	B	A	C
4 to 20mA HART, Li=0	E	D	F
PROFIBUS PA	N	M	O
FOUNDATION Fieldbus	Q	P	R

1) Product Configurator, order code for "Display, operation:"

### Signal range

**4 to 20 mA**  
3.8 mA to 20.5 mA

### Signal on alarm

**4 to 20 mA HART**

As per NAMUR NE43.

- Max. alarm: can be set from 21 to 23 mA (factory setting: 22 mA)
- Hold measured value: last measured value is held
- Min. alarm: 3.6 mA

#### PROFIBUS PA

As per NAMUR NE43.

Can be set in the Analog Input Block.

Options:

- Last Valid Out Value (factory setting)
- Fail Safe Value
- Status bad

#### FOUNDATION Fieldbus

As per NAMUR NE43.

Can be set in the Analog Input Block.

Options:

- Last Good Value
- Fail Safe Value (factory setting)
- Wrong Value

### Load

**4 to 20 mA HART**

In order to guarantee sufficient terminal voltage in two-wire devices, a maximum load resistance R (including line resistance) must not be exceeded depending on the supply voltage  $U_0$  of the supply unit. In the following load diagrams, observe the position of the jumper and the explosion protection:

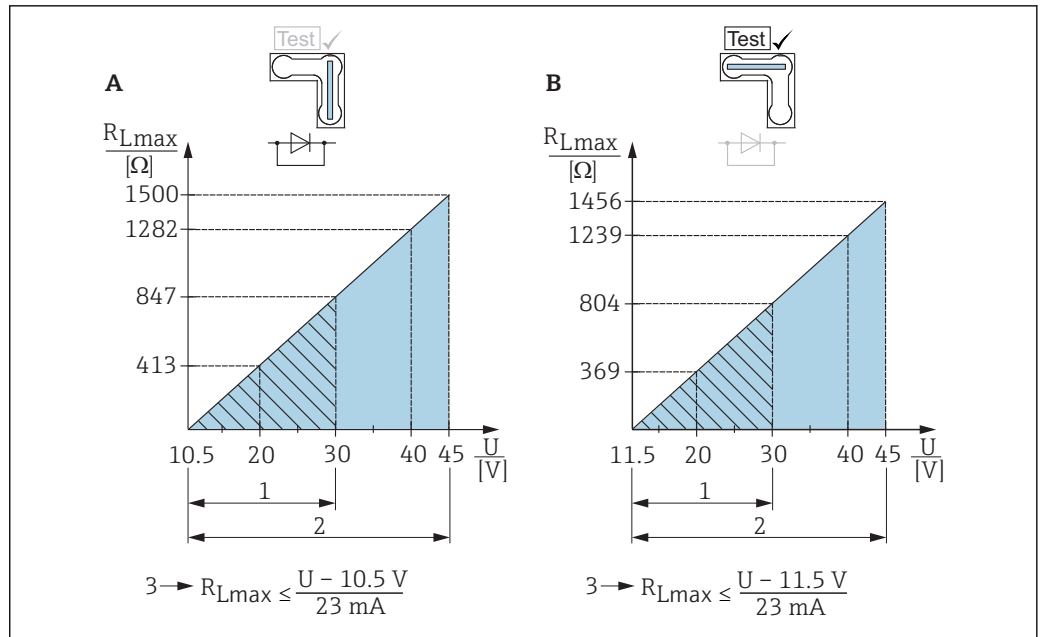

A0019988

- A Jumper for 4 to 20 mA test signal set to "Non-test" position
- B Jumper for 4 to 20 mA test signal set to "Test" position
- 1 Power supply 10.5 (11.5) to 30 V DC for 1/2 G Ex ia, 1GD Ex ia, 1/2 GD Ex ia, FM IS, CSA IS, IECEx ia, NEPSI Ex ia
- 2 Power supply 10.5 (11.5) to 45 V DC for devices for non-hazardous areas, 1/2 D, 1/3 D, 2 G Ex d, 3 G Ex nA, FM XP, FM DIP, FM NI, CSA XP, CSA dust ignition-proof, NEPSI Ex d
- 3  $R_{Lmax}$  maximum load resistance
- U Supply voltage

**i** When operating via a handheld terminal or via a PC with an operating program, a minimum communication resistor of 250 Ω must be taken into account.

**Damping**

A damping affects all outputs (output signal, display):

- Via onsite display, handheld terminal or PC with operating program, continuous from 0 to 999 s
- Also for HART and PROFIBUS PA: Via DIP switch on the electronic insert, switch position "on" = set value and "off"
- Factory setting: 2 s

**Alarm current**

Designation	Option <sup>1)</sup>
Min alarm current	J
HART burst mode PV	J
Min alarm current + HART burst mode PV	J

1) Product Configurator, order code for "Additional options 1" and "Additional options 2"

**Firmware version**

Designation	Option <sup>1)</sup>
02.20.zz, HART 7, DevRev22	72
02.11.zz, HART 5, DevRev21	73
04.00.zz, FF, DevRev07	74
04.01.zz, PROFIBUS PA, DevRev03	75
02.10.zz, HART 5, DevRev21	76
03.00.zz, FF, DevRev06	77

Designation	Option <sup>1)</sup>
04.00.zz, PROFIBUS PA	78
02.30.zz, HART 7	71

1) Product Configurator, order code for "Firmware version"

#### Protocol-specific data HART

Manufacturer ID	17 (11 hex)
Device type ID	23 (17 hex)
Device revision	<ul style="list-style-type: none"> <li>▪ 21 (15 hex) - SW version 02.1y.zz - HART specification 5</li> <li>▪ 22 (16 hex) - SW version 02.2y.zz - HART specification 7</li> </ul>
HART specification	<ul style="list-style-type: none"> <li>▪ 5</li> <li>▪ 7</li> </ul>
DD revision	<ul style="list-style-type: none"> <li>▪ 4 (Russian in language selection) for device revision 21</li> <li>▪ 3 (Dutch in language selection) for device revision 21</li> <li>▪ 1 for device revision 22</li> </ul>
Device description files (DTM, DD)	Information and files under: <ul style="list-style-type: none"> <li>▪ <a href="http://www.endress.com">www.endress.com</a></li> <li>▪ <a href="http://www.fieldcommgroup.org">www.fieldcommgroup.org</a></li> </ul>
HART load	Min. 250 Ω
HART device variables	<p>The measured values are assigned to the device variables as follows:</p> <p><b>Measured values for PV (primary variable)</b></p> <ul style="list-style-type: none"> <li>▪ Pressure</li> <li>▪ Flow</li> <li>▪ Level</li> <li>▪ Tank content</li> </ul> <p><b>Measured values for SV, TV (second and third variable)</b></p> <ul style="list-style-type: none"> <li>▪ Pressure</li> <li>▪ Totalizer</li> </ul> <p><b>Measured values for QV (fourth variable)</b></p> <p>Temperature</p>
Supported functions	<ul style="list-style-type: none"> <li>▪ Burst mode</li> <li>▪ Additional transmitter status</li> <li>▪ Device locking</li> <li>▪ Alternative measuring modes</li> </ul>

#### Wireless HART data

Minimum starting voltage	11.5 V (default) or 10.5 V if jumper not set to "Test" position <sup>1)</sup>
Start-up current	12 mA
Starting time	10 s
Minimum operating voltage	11.5 V (default) or 10.5 V if jumper not set to "Test" position <sup>1)</sup>
Multidrop current	4 mA
Time for connection setup	1 s

1) Or higher if operating near the ambient temperature limits (-40 to +85 °C (-40 to +185))

#### Protocol-specific data PROFIBUS PA

Manufacturer ID	17 (11 hex)
Identification number	1542 hex
Profile version	<p>3.0</p> <ul style="list-style-type: none"> <li>▪ SW version 03.00.zz</li> <li>▪ SW version 04.00.zz</li> </ul> <p>3.02</p> <p>SW version 04.01.zz ( device revision 3)</p> <p>Compatibility with SW version 03.00.zz and higher.</p>
GSD revision	<ul style="list-style-type: none"> <li>▪ 4 (SW version 3.00.zz and 4.00.zz)</li> <li>▪ 5 (device revision 3)</li> </ul>

DD revision	<ul style="list-style-type: none"> <li>▪ 1 (SW version 3.00.zz and 4.00.zz)</li> <li>▪ 1 (device revision 3)</li> </ul>
GSD file	Information and files under:
DD files	<ul style="list-style-type: none"> <li>▪ <a href="http://www.endress.com">www.endress.com</a></li> <li>▪ <a href="http://www.profibus.org">www.profibus.org</a></li> </ul>
Output values	<p><b>Measured values for PV (via Analog Input Function Block)</b></p> <ul style="list-style-type: none"> <li>▪ Pressure</li> <li>▪ Level</li> <li>▪ Flow</li> <li>▪ Tank content</li> </ul> <p><b>Measured values for SV</b></p> <ul style="list-style-type: none"> <li>▪ Pressure</li> <li>▪ Temperature</li> </ul> <p><b>Measured value for QV</b> Totalizer</p>
Input values	Input value sent from PLC, can be shown on display
Supported functions	<ul style="list-style-type: none"> <li>▪ Identification &amp; maintenance, simplest device identifier on the control system and nameplate</li> <li>▪ Condensed status (only with Profile Version 3.02)</li> <li>▪ Automatic ID number adjustment and switchable to the following ID numbers (only with Profile Version 3.02): <ul style="list-style-type: none"> <li>▪ 9700: Profile-specific transmitter identification number with the "Classic" or "Condensed" status.</li> <li>▪ 1504: Compatibility mode for the old Deltabar S generation (FMD230, FMD630, FMD633, PMD230, PMD235).</li> <li>▪ 1542: Identification number of the new Deltabar S generation (FMD77, FMD78, PMD75).</li> </ul> </li> <li>▪ Device locking: The device can be locked by hardware or software.</li> </ul>

**Protocol-specific data  
FOUNDATION Fieldbus**

Manufacturer ID	452B48 hex
Device type	1009 hex
Device revision	<ul style="list-style-type: none"> <li>▪ 6 - SW version 03.00.zz</li> <li>▪ 7 - SW version 04.00.zz (FF-912)</li> </ul>
DD revision	<ul style="list-style-type: none"> <li>▪ 3 (device revision 6)</li> <li>▪ 2 (device revision 7)</li> </ul>
CFF revision	<ul style="list-style-type: none"> <li>▪ 4 (device revision 6)</li> <li>▪ 1 (device revision 7)</li> </ul>
DD files	Information and files under:
CFF files	<ul style="list-style-type: none"> <li>▪ <a href="http://www.endress.com">www.endress.com</a></li> <li>▪ <a href="http://www.fieldcommgroup.org">www.fieldcommgroup.org</a></li> </ul>
Device tester version (ITK version)	<ul style="list-style-type: none"> <li>▪ 5.0 (device revision 6)</li> <li>▪ 6.01 (device revision 7)</li> </ul>
Number of ITK test campaign	<ul style="list-style-type: none"> <li>▪ IT054700 (Device Revision 6)</li> <li>▪ IT085400 (Device Revision 7)</li> </ul>
Link-Master (LAS) capable	Yes
Choice of "Link Master" and "Basic Device"	Yes; Factory setting: Basic Device
Node address	Factory setting: 247 (F7 hex)
Supported functions	<p>Field diagnostics profile (only with FF912)</p> <p>The following methods are supported:</p> <ul style="list-style-type: none"> <li>▪ Reboot</li> <li>▪ Configure error as warning or alarm</li> <li>▪ HistoROM</li> <li>▪ Peakhold</li> <li>▪ Alarm info</li> <li>▪ Sensor trim</li> </ul>

Number of VCRs	<ul style="list-style-type: none"> <li>▪ 44 (device revision 6)</li> <li>▪ 24 (device revision 7)</li> </ul>
Number of Link Objects in VFD	50

### Virtual communication references (VCRs)

	Device revision 6	Device revision 7
Permanent Entries	44	1
Client VCRs	0	0
Server VCRs	5	10
Source VCRs	8	43
Sink VCRs	0	0
Subscriber VCRs	12	43
Publisher VCRs	19	43

### Link settings

	Device revision 6	Device revision 7
Slot time	4	4
Min. Inter PDU delay	12	10
Max. response delay	10	10

### Transducer Blocks

Block	Contents	Output values
TRD1 Block	Contains all parameters related to the measurement	<ul style="list-style-type: none"> <li>▪ Pressure, flow or level (channel 1)</li> <li>▪ Process temperature (channel 2)</li> </ul>
Service Block	Contains service information	<ul style="list-style-type: none"> <li>▪ Pressure after damping (channel 3)</li> <li>▪ Pressure peakhold indicator (channel 4)</li> <li>▪ Counter for max. pressure transgressions (channel 5)</li> </ul>
Dp Flow Block	Contains flow and totalizer parameters	Totalizer 1 (channel 6)
Diagnostic block	Contains diagnostic information	Error code via DI channels (channel 0 to 16)
Display block	Contains parameters to configure the onsite display	No output values

**Function blocks**

Block	Contents	Number Blocks	Execution time		Functionality	
			Device Revision 6	Device Revision 7	Device Revision 6	Device Revision 7
Resource Block	The Resource Block contains all the data that uniquely identify the device. It is an electronic version of a nameplate of the device.	1			enhanced	enhanced
Analog Input Block 1 Analog Input Block 2 Analog Input Block 3	The AI Block receives the measuring data from the Sensor Block, (selectable via a channel number) and makes the data available to other function blocks at its output. Enhancement: Digital outputs for process alarms, fail safe mode	3	45 ms	45 ms (without trend and alarm reports)	enhanced	enhanced
Digital Input Block	This block contains the discrete data of the Diagnose Block (selectable via a channel number 0 to 16) and provides them for other blocks at the output.	1	40 ms	30 ms	standard	enhanced
Digital Output Block	This block converts the discrete input and thus initiates an action (selectable via a channel number) in the DP Flow Block or in the Service Block. Channel 1 resets the counter for max. pressure transgressions.	1	60 ms	40 ms	standard	enhanced
PID Block	This block is used as a proportional-integral-derivative controller and can be used universally for closed-loop-control in the field. It enables cascade mode and feedforward control. Input IN can be indicated on the display. The selection is performed in the Display Block (DISPLAY_MAIN_LINE_CONTENT).	1	120 ms	70 ms	standard	enhanced
Arithmetic Block	This block is designed to permit simple use of popular measurement math functions. The user does not have to know how to write equations. The math algorithm is selected by name, chosen by the user for the function to be performed.	1	50 ms	40 ms	standard	enhanced
Input Selector Block	The Input Selector Block facilitates the selection of up to four inputs and generates an output based on the configured action. This block normally receives its inputs from AI Blocks. The block enables the selection of maximum, minimum, average and 'first good' values. Inputs IN1 to IN4 can be shown on the display. The selection is performed in the Display Block (DISPLAY_MAIN_LINE_CONTENT).	1	35 ms	35 ms	standard	enhanced
Signal Characterizer Block	The Signal Characterizer Block has two sections, each with an output value that is a non-linear function of the input value. The non-linear function is generated by a single look-up table with 21 arbitrary x-y pairs.	1	30 ms	40 ms	standard	enhanced
Integrator Block	The Integrator Block integrates a variable as a function of the time or accumulates the counts from a Pulse Input Block. The block may be used as a totalizer that counts up until reset or as a batch totalizer that has a setpoint, where the integrated or accumulated value is compared to pre-trip and trip settings, generating a binary signal when the setpoint is reached.	1	35 ms	40 ms	standard	enhanced
Analog Alarm Block	This block contains all process alarm conditions (working like a comparator) and represents them at the output.	1	35 ms	35 ms	standard	enhanced

*Additional function block information:*

Instantiate Function Block	JA	JA
Number of additional instantiatable function blocks	9	4

## Power supply

### ⚠ WARNING

#### Electrical safety is compromised by an incorrect connection!

- ▶ When using the measuring device in hazardous areas, the relevant national standards and regulations as well as the Safety Instructions or Installation or Control Drawings must be observed → 114.
- ▶ All the explosion protection data are given in separate documentation which is available upon request. The Ex documentation is supplied as standard with all Ex-devices → 114.
- ▶ Devices with integrated overvoltage protection must be grounded → 23.
- ▶ Protective circuits against reverse polarity, HF influences and overvoltage peaks are integrated.

### Terminal assignment

#### 4 to 20 mA HART

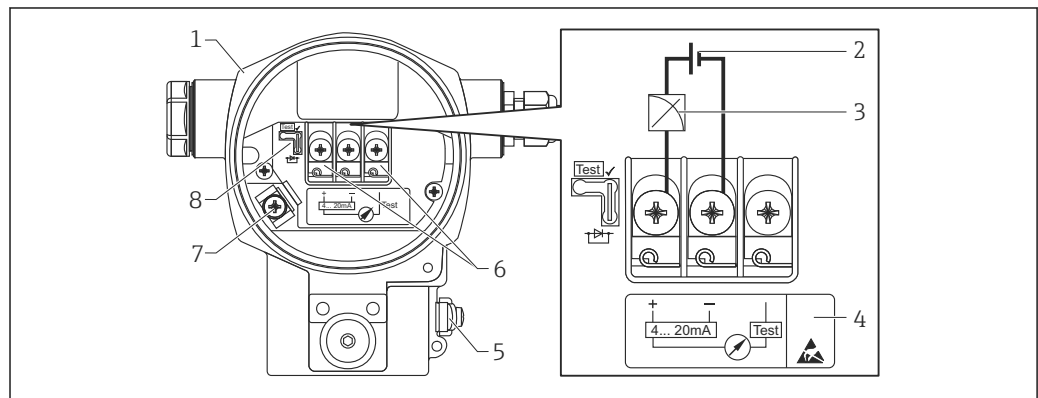

A0019989

- 1 Housing
- 2 Supply voltage
- 3 4 to 20 mA
- 4 Devices with integrated overvoltage protection are labeled "OVP" (overvoltage protection) here.
- 5 External ground terminal
- 6 4 to 20 mA test signal between positive and test terminal
- 7 Internal ground terminal
- 8 Jumper for 4 to 20 mA test signal → 21

#### PROFIBUS PA and FOUNDATION Fieldbus

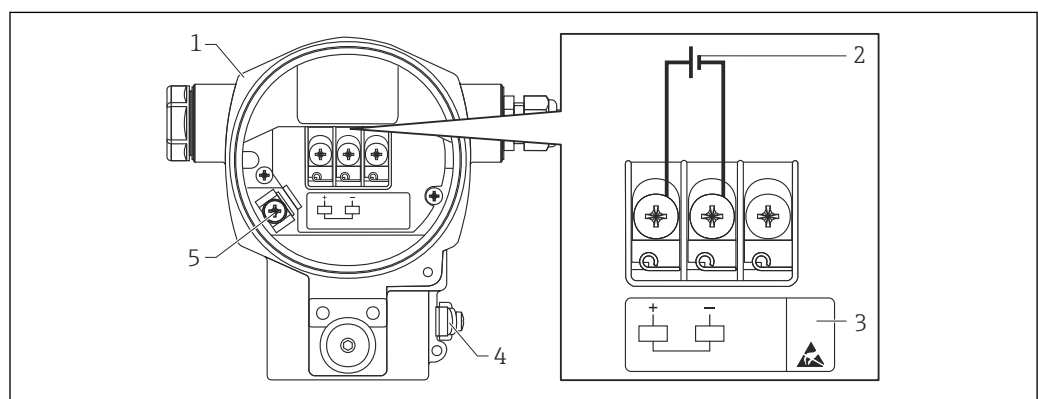

A0020158

- 1 Housing
- 2 Supply voltage
- 3 Devices with integrated overvoltage protection are labeled "OVP" (overvoltage protection) here.
- 4 External ground terminal
- 5 Internal ground terminal

**Supply voltage**

**4 to 20 mA HART**

Electronic version	Jumper for 4 to 20 mA test signal in "Test" position (delivery status)	Jumper for 4 to 20 mA test signal in "Non-test" position
Version for non-hazardous area	11.5 to 45 V DC	10.5 to 45 V DC
Intrinsically safe	11.5 to 30 V DC	10.5 to 30 V DC
<ul style="list-style-type: none"> <li>▪ Other types of protection</li> <li>▪ Devices without certificate</li> </ul>	11.5 to 45 V DC (versions with 35 V DC plug-in connection)	10.5 to 45 V DC (versions with 35 V DC plug-in connection)

*Measuring a 4 to 20 mA test signal*

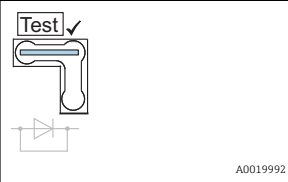
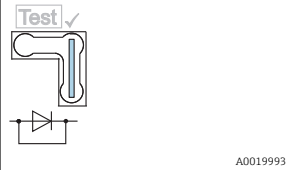
Jumper position for test signal	Description
	<ul style="list-style-type: none"> <li>▪ Measurement of 4-20 mA test signal via the positive and test terminal: Possible. (Thus, the output current can be measured without interruption via the diode.)</li> <li>▪ As-delivered state</li> <li>▪ Minimum supply voltage: 11.5 V DC</li> </ul>
	<ul style="list-style-type: none"> <li>▪ Measurement of 4-20 mA test signal via positive and test terminal: Not possible.</li> <li>▪ Minimum supply voltage: 10.5 V DC</li> </ul>

**PROFIBUS PA**

- Version for non-hazardous areas: 9 to 32 V DC
- Ex ia: 10.5 to 30 V DC

**FOUNDATION Fieldbus**

- Version for non-hazardous areas: 9 to 32 V DC
- Ex ia: 10.5 to 30 V DC

**Current consumption**

- PROFIBUS PA: 13 mA ±1 mA, switch-on current corresponds to IEC 61158-2, Clause 21
- FOUNDATION Fieldbus: 15.5 mA ±1 mA, switch-on current corresponds to IEC 61158-2, Clause 21

**Electrical connection**

**PROFIBUS PA**

The digital communication signal is transmitted to the bus via a two-wire connection. The bus also provides the power supply. For further information on the network structure and grounding and for further bus system components such as bus cables, see the relevant documentation, e.g. Operating Instructions BA00034S "PROFIBUS DP/PA: Guidelines for planning and commissioning" and the PNO Guideline.

**FOUNDATION Fieldbus**

The digital communication signal is transmitted to the bus via a two-wire connection. The bus also provides the power supply. For further information on the network structure and grounding and for further bus system components such as bus cables, see the relevant documentation, e.g. Operating Instructions BA00013S "FOUNDATION Fieldbus Overview" and the FOUNDATION Fieldbus Guideline.

**Terminals**

- Supply voltage and internal ground terminal: 0.5 to 2.5 mm<sup>2</sup> (20 to 14 AWG)
- External ground terminal: 0.5 to 4 mm<sup>2</sup> (20 to 12 AWG)

## Cable entries

Approval	Cable gland	Clamping range
Standard, II 1/2 G Ex ia, IS	Plastic M20x1.5	5 to 10 mm (0.2 to 0.39 in)
ATEX II 1/2 D, II 1/3 D, II 1/2 GD Ex ia, II 1 GD Ex ia, II 3 G Ex nA	Metal M20x1.5 (Ex e)	7 to 10.5 mm (0.28 to 0.41 in)

For additional technical data, see section on housing → 47

## Device plugs

## Connection of devices with Harting plug Han7D

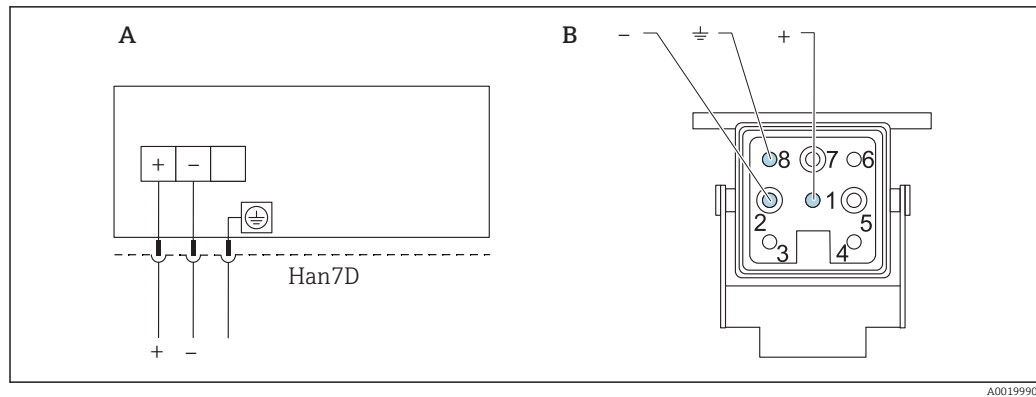

A Electrical connection for devices with Harting plug Han7D  
B View of the plug-in connection on the device

Material: CuZn, contacts for plug-in jack and connector are gold-plated

## Connection of devices with M12 plug

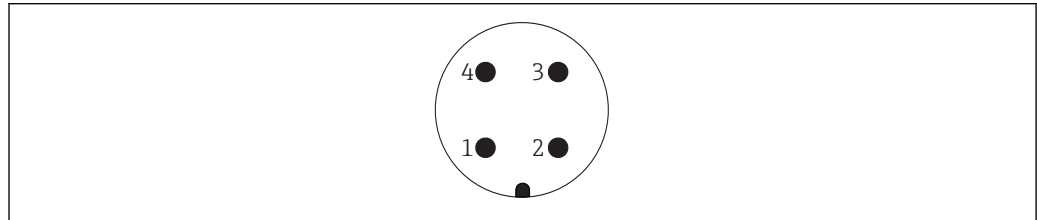

- 1 Signal +
- 2 Not assigned
- 3 Signal -
- 4 Ground

Endress+Hauser offers the following accessories for devices with an M12 plug:

Plug-in jack M 12x1, straight

- Material: body PA; coupling nut CuZn, nickel-plated
- Degree of protection (fully locked): IP67
- Order number: 52006263

Plug-in jack M 12x1, elbowed

- Material: body PBT/PA; coupling nut GD-Zn, nickel-plated
- Degree of protection (fully locked): IP67
- Order number: 71114212

Cable 4x0.34 mm<sup>2</sup> (20 AWG) with M12 socket, elbowed, screw plug, length 5 m (16 ft)

- Material: body PUR; coupling nut CuSn/Ni; cable PVC
- Degree of protection (fully locked): IP67
- Order number: 52010285

**Connection of devices with 7/8" plug**

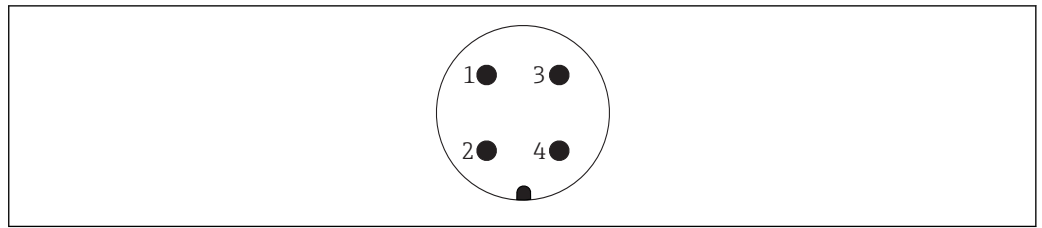

A0011176

- 1 Signal -
- 2 Signal +
- 3 Not assigned
- 4 Shielding

- External thread: 7/8 - 16 UNC
- Material: 316L (1.4401)
- Degree of protection: IP68

**Cable specification**

**HART**

- Endress+Hauser recommends using shielded, twisted-pair two-wire cables.
- Cable outer diameter: 5 to 9 mm (0.2 to 0.35 in) depending on the cable entry used → 22

**PROFIBUS PA**

Use a twisted, shielded twin-core cable, preferably cable type A.

**i** For further information on the cable specifications, see Operating Instructions BA00034S "PROFIBUS DP/PA: Guidelines for planning and commissioning", the PNO Guideline 2.092 "PROFIBUS PA User and Installation Guideline" and IEC 61158-2 (MBP).

**FOUNDATION Fieldbus**

Use a twisted, shielded twin-core cable, preferably cable type A.

**i** For further information on the cable specifications, see Operating Instructions BA00013S "FOUNDATION Fieldbus Overview", FOUNDATION Fieldbus Guideline and IEC 61158-2 (MBP).

**Start-up current**

12 mA

**Residual ripple**

Without influence on 4 to 20 mA signal up to ±5% residual ripple within the permitted voltage range [according to HART hardware specification HCF\_SPEC-54 (DIN IEC 60381-1)].

**Overvoltage protection (optionally for HART, PROFIBUS PA and FOUNDATION Fieldbus)**

- Overvoltage protection:
  - Nominal functioning DC voltage: 600 V
  - Nominal discharge current: 10 kA
- Surge current check  $\hat{i} = 20$  kA satisfied as per DIN EN 60079-14: 8/20  $\mu$ s
- Arrester AC current check  $I = 10$  A satisfied

Ordering information: Product Configurator, order code for "Additional options 1" or Additional options 2", option "M"

**NOTICE**

**Device could be destroyed!**

- ▶ Devices with integrated overvoltage protection must be grounded.

**Influence of power supply**

≤0.0006 % of URV/1 V

## Performance characteristics

<b>Response time</b>	<p><b>HART</b></p> <ul style="list-style-type: none"> <li>■ Acyclic: min. 330 ms, typically 590 ms (depending on command # and number of preambles)</li> <li>■ Cyclic (burst): min. 160 ms, typically 350 ms (depending on command # and number of preambles)</li> </ul> <p><b>PROFIBUS PA</b></p> <ul style="list-style-type: none"> <li>■ Acyclic: approx. 60 ms to 70 ms (depending on Min. Slave Interval)</li> <li>■ Cyclic: approx. 10 ms to 13 ms (depending on Min. Slave Interval)</li> </ul> <p><b>FOUNDATION Fieldbus</b></p> <ul style="list-style-type: none"> <li>■ Acyclic: typically 100 ms (for standard bus parameter settings)</li> <li>■ Cyclic: max. 20 ms (for standard bus parameter settings)</li> </ul>
<b>Reference operating conditions</b>	<ul style="list-style-type: none"> <li>■ As per IEC 62828-2 / IEC 60770</li> <li>■ Ambient temperature <math>T_A</math> = constant, in the range +21 to +33 °C (+70 to +91 °F)</li> <li>■ Humidity <math>\phi</math> = constant, in the range: 5 to 80 % RH <math>\pm</math> 5 %</li> <li>■ Ambient pressure <math>p_A</math> = constant, in the range: 860 to 1060 mbar (12.47 to 15.37 psi)</li> <li>■ Position of the measuring cell: horizontal <math>\pm</math>1°</li> <li>■ Input of LOW SENSOR TRIM and HIGH SENSOR TRIM for lower range value and upper range value</li> <li>■ Zero based span</li> <li>■ Membrane material for PMD75: AISI 316L (1.4435), Alloy C276, gold/rhodium-coated, Monel</li> <li>■ Membrane material for FMD77, FMD78: AISI 316L (1.4435)</li> <li>■ Filling oil: silicone oil</li> <li>■ Supply voltage: 24 V DC <math>\pm</math>3 V DC</li> <li>■ Load with HART: 250 <math>\Omega</math></li> <li>■ Turn down (TD) = <math>URL /  URV - LRV </math></li> </ul>
<b>Maximum measured error (total performance)</b>	<p>The performance characteristics refer to the accuracy of the measuring device. The factors influencing accuracy can be divided into two groups</p> <ul style="list-style-type: none"> <li>■ Total performance of measuring device</li> <li>■ Installation factors</li> </ul> <p>All performance characteristics are in conformance with <math>\geq \pm 3</math> sigma.</p> <p>The total performance of the measuring device comprises the reference accuracy and the ambient temperature effect and is calculated using the following formula:</p> $\text{Total performance} = \pm \sqrt{(E1)^2 + (E2)^2 + (E3)^2}$ <p>E1 = Reference accuracy</p> <p>E2 = Temperature effect per <math>\pm 28</math> °C (50 °F)</p> <p>(corresponds to the range from -3 to +53 °C (+27 to +127 °F))</p> <p>Calculation of E2:</p> $E2 = E2_M + E2_E$ <p><math>E2_M</math> = Main temperature error</p> <p><math>E2_E</math> = Electronics error</p> <p>E3 = Static pressure effect</p> <ul style="list-style-type: none"> <li>■ The values apply for process isolating diaphragm made of 316L (1.4435)</li> <li>■ The values refer to the calibrated span</li> </ul>

**Calculation of the total performance with the Endress+Hauser Applicator**

Detailed measured errors, such as for other temperature ranges, for example, can be calculated with the Applicator "[Sizing Pressure Performance](#)".



A0038927

**Calculation of the diaphragm seal error with the Endress+Hauser Applicator**

Diaphragm seal errors are not taken into consideration. Diaphragm seal errors are calculated separately in the Applicator "[Sizing Diaphragm Seal](#)".



A0038925

**Reference accuracy [E1]**

Reference accuracy comprises the non-linearity [IEC 62828-1 / DIN EN 61298-2] including the hysteresis [IEC 62828-1 / DIN EN 61298-2] and the non-repeatability [IEC 62828-1 / DIN EN 61298-2] in accordance with the limit point method as per [IEC 62828-1 / DIN EN 60770-2]. Reference accuracy for standard up to TD 100:1, for platinum up to TD 5:1.

*PMD75*

10 mbar (0.15 psi) sensor

- Standard: TD 1:1 =  $\pm 0.075\%$ ; TD > 1:1 =  $\pm 0.075\% \cdot \text{TD}$
- Platinum: TD 1:1 =  $\pm 0.05\%$ ; TD > 1:1 =  $\pm 0.075\% \cdot \text{TD}$

30 mbar (0.45 psi) sensor

- Standard: TD  $\leq$  3:1 =  $\pm 0.075\%$ ; TD > 3:1 =  $\pm 0.025\% \cdot \text{TD}$
- Platinum: TD 1:1 =  $\pm 0.05\%$ ; TD > 1:1 to TD  $\leq$  3:1 =  $\pm 0.075\%$ ; TD > 3:1 =  $\pm 0.025\% \cdot \text{TD}$

100 mbar (1.5 psi) sensor

- Standard: TD  $\leq$  5:1 =  $\pm 0.05\%$ ; TD > 5:1 =  $\pm(0.009\% \cdot \text{TD} + 0.005\%)$
- Platinum: TD  $\geq$  1:1 =  $\pm 0.04\%$

500 mbar (7.5 psi), 3 bar (45 psi), 16 bar (240 psi), 40 bar (600 psi) sensor

- Standard: TD  $\leq$  15:1 =  $\pm 0.05\%$ ; TD > 15:1 =  $\pm(0.0015\% \cdot \text{TD} + 0.0275\%)$
- Platinum: TD  $\geq$  1:1 =  $\pm 0.035\%$

160 bar (2 400 psi) and 250 bar (3 750 psi) gauge pressure sensor and absolute pressure sensor

- Standard: TD  $\leq$  5:1 =  $\pm 0.10\%$ ; TD > 5:1 =  $\pm 0.02\% \cdot \text{TD}$
- Platinum: -

*FMD77*

100 mbar (1.5 psi) sensor

TD  $\leq$  5:1 =  $\pm 0.10\%$ ; TD > 5:1 =  $\pm 0.02\% \cdot \text{TD}$

500 mbar (7.5 psi) sensor

TD  $\leq$  15:1 =  $\pm 0.075\%$ ; TD > 15:1 =  $\pm(0.0015\% \cdot \text{TD} + 0.053\%)$

3 bar (45 psi) and 16 bar (240 psi) sensor

TD  $\leq$  15:1 =  $\pm 0.075\%$ ; TD > 15:1 =  $\pm(0.0015\% \cdot \text{TD} + 0.053\%)$

*FMD77 with capillary on low-pressure side and FMD78*

100 mbar (1.5 psi) sensor

TD  $\leq$  5:1 =  $\pm 0.15\%$ ; TD > 5:1 =  $\pm 0.03\% \cdot \text{TD}$

500 mbar (7.5 psi) sensor

3 bar (45 psi) and 16 bar (240 psi) sensor  
TD  $\leq$  15:1 =  $\pm 0.1\%$ ; TD > 15:1 =  $\pm(0.006\% \cdot \text{TD} + 0.01\%)$

40 bar (600 psi) sensor

TD  $\leq$  15:1 =  $\pm 0.1\%$ ; TD > 15:1 =  $\pm(0.006\% \cdot \text{TD} + 0.01\%)$

**Temperature effect [E2]***E2<sub>M</sub> - Main temperature error*

The output changes due to the effect of the ambient temperature [IEC 62828-1 / IEC 61298-3] with respect to the reference temperature [IEC 62828-1 / DIN 16086]. The values specify the maximum error due to min./max. ambient or process temperature conditions.

10 mbar (0.15 psi) and 30 mbar (0.45 psi) sensor

- Standard:  $\pm(0.14 \% \cdot TD + 0.04 \%)$
- Platinum:  $\pm(0.14 \% \cdot TD + 0.04 \%)$

100 mbar (1.5 psi) sensor

- Standard:  $\pm(0.07 \% \cdot TD + 0.07 \%)$
- Platinum:  $\pm(0.07 \% \cdot TD + 0.07 \%)$

500 mbar (7.5 psi) sensor

- Standard:  $\pm(0.03 \% \cdot TD + 0.017 \%)$
- Platinum:  $\pm(0.03 \% \cdot TD + 0.017 \%)$

3 bar (45 psi), 16 bar (240 psi) and 40 bar (600 psi) sensor

- Standard:  $\pm(0.012 \% \cdot TD + 0.017 \%)$
- Platinum:  $\pm(0.012 \% \cdot TD + 0.017 \%)$

160 bar (2 400 psi) gauge pressure sensor and absolute pressure sensor

- Standard:  $\pm(0.042 \% \cdot TD + 0.04 \%)$
- Platinum: -

250 bar (3 750 psi) gauge pressure sensor and absolute pressure sensor

- Standard:  $\pm(0.022 \% \cdot TD + 0.04 \%)$
- Platinum: -

*E2<sub>E</sub> - Electronics error*

- Analog output (4 to 20 mA): 0.05 %
- Digital output (HART/PA/FF): 0 %

**E3<sub>M</sub> - Main static pressure error**

The static pressure effect refers to the effect on the output due to changes in the static pressure of the process (difference between the output at each static pressure and the output at atmospheric pressure [IEC 62828-2 / IEC 61298-3] and therefore the combination of the influence of the operating pressure on the zero point and the span).

10 mbar (0.15 psi) sensor

- Standard
  - Influence on the zero point:  $\pm 0.15 \cdot TD \% \text{ per } 7 \text{ bar (105 psi)}$
  - Influence on the span:  $\pm 0.035 \% \text{ per } 7 \text{ bar (105 psi)}$
- Platinum
  - Influence on the zero point:  $\pm 0.07 \% \cdot TD \text{ per } 7 \text{ bar (105 psi)}$
  - Influence on the span:  $\pm 0.035 \% \text{ per } 7 \text{ bar (105 psi)}$

30 mbar (0.45 psi) sensor

- Standard
  - Influence on the zero point:  $\pm 0.70 \% \cdot TD \text{ per } 70 \text{ bar (1 050 psi)}$
  - Influence on the span:  $\pm 0.14 \% \text{ per } 70 \text{ bar (1 050 psi)}$
- Platinum
  - Influence on the zero point:  $\pm 0.25 \% \cdot TD \text{ per } 70 \text{ bar (1 050 psi)}$
  - Influence on the span:  $\pm 0.14 \% \text{ per } 70 \text{ bar (1 050 psi)}$

100 mbar (1.5 psi) sensor

- Standard
  - Influence on the zero point:  $\pm 0.203 \% \cdot TD \text{ per } 70 \text{ bar (1 050 psi)}$
  - Influence on the span:  $\pm 0.15 \% \text{ per } 70 \text{ bar (1 050 psi)}$
- Platinum
  - Influence on the zero point:  $\pm 0.077 \% \cdot TD \text{ per } 70 \text{ bar (1 050 psi)}$
  - Influence on the span:  $\pm 0.15 \% \text{ per } 70 \text{ bar (1 050 psi)}$

500 mbar (7.5 psi) sensor

- Standard
  - Influence on the zero point:  $\pm 0.07\% \cdot \text{TD}$  per 70 bar (1050 psi)
  - Influence on the span:  $\pm 0.10\%$  per 70 bar (1050 psi)
- Platinum
  - Influence on the zero point:  $\pm 0.028\% \cdot \text{TD}$  per 70 bar (1050 psi)
  - Influence on the span:  $\pm 0.10\%$  per 70 bar (1050 psi)

3 bar (45 psi) sensor

- Standard
  - Influence on the zero point:  $\pm 0.049\% \cdot \text{TD}$  per 70 bar (1050 psi)
  - Influence on the span:  $\pm 0.05\%$  per 70 bar (1050 psi)
- Platinum
  - Influence on the zero point:  $\pm 0.021\% \cdot \text{TD}$  per 70 bar (1050 psi)
  - Influence on the span:  $\pm 0.05\%$  per 70 bar (1050 psi)

16 bar (240 psi) and 40 bar (600 psi) sensor

- Standard
  - Influence on the zero point:  $\pm 0.049\% \cdot \text{TD}$  per 70 bar (1050 psi)
  - Influence on the span:  $\pm 0.02\%$  per 70 bar (1050 psi)
- Platinum
  - Influence on the zero point:  $\pm 0.021\% \cdot \text{TD}$  per 70 bar (1050 psi)
  - Influence on the span:  $\pm 0.02\%$  per 70 bar (1050 psi)

160 bar (2400 psi) and 250 bar (3750 psi) gauge pressure sensor and absolute pressure sensor

- Standard
  - Influence on the zero point: -
  - Influence on the span: -
- Platinum
  - Influence on the zero point: -
  - Influence on the span: -

---

#### Resolution

Current output: 1  $\mu\text{A}$

---

#### Total error

The total error of the measuring device comprises the total performance and the influence of long-term stability and is calculated using the following formula:

Total error = total performance + long-term stability

#### Calculation of the total error with the Endress+Hauser Applicator

Detailed measured errors, such as for other temperature ranges, for example, can be calculated with the Applicator "[Sizing Pressure Performance](#)".



A0038927

#### Calculation of the diaphragm seal error with the Endress+Hauser Applicator

Diaphragm seal errors are not taken into consideration. Diaphragm seal errors are calculated separately in the Applicator "[Sizing Diaphragm Seal](#)".



A0038925

---

**Long-term stability**

10 mbar (0.15 psi) and 30 mbar (0.45 psi) sensor

- 1 year:  $\pm 0.20$  %
- 5 years:  $\pm 0.28$  %
- 10 years:  $\pm 0.31$  %

100 mbar (1.5 psi) sensor

- 1 year:  $\pm 0.08$  %
- 5 years:  $\pm 0.14$  %
- 10 years:  $\pm 0.27$  %

500 mbar (7.5 psi) sensor

- 1 year:  $\pm 0.03$  %
- 5 years:  $\pm 0.05$  %
- 10 years:  $\pm 0.08$  %

3 bar (45 psi) sensor

- 1 year:  $\pm 0.04$  %
- 5 years:  $\pm 0.08$  %
- 10 years:  $\pm 0.15$  %

16 bar (240 psi) sensor

- 1 year:  $\pm 0.03$  %
- 5 years:  $\pm 0.11$  %
- 10 years:  $\pm 0.21$  %

40 bar (600 psi) sensor

- 1 year:  $\pm 0.05$  %
- 5 years:  $\pm 0.07$  %
- 10 years:  $\pm 0.10$  %

160 bar (2 400 psi) and 250 bar (3 750 psi) gauge pressure sensor and absolute pressure sensor

- 1 year:  $\pm 0.05$  %
- 5 years:  $\pm 0.07$  %
- 10 years:  $\pm 0.10$  %

**Response time T63 and T90 Dead time, time constant**

Presentation of the dead time and the time constant:

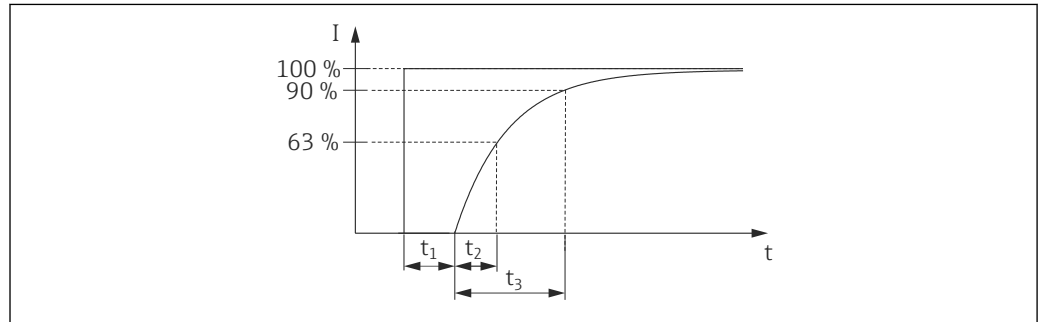

A0019786

**Dynamic behavior, current output**

Type		Sensor	Dead time (t <sub>1</sub> )	Time constant T63 (t <sub>2</sub> )	Time constant T90 (t <sub>3</sub> )
PMD75	Max.	<ul style="list-style-type: none"> <li>▪ 10 mbar (0.15 psi)</li> <li>▪ 30 mbar (0.45 psi)</li> <li>▪ 100 mbar (1.5 psi)</li> <li>▪ 500 mbar (7.5 psi)</li> <li>▪ 3 bar (45 psi)</li> <li>▪ 16 bar (240 psi)</li> <li>▪ 40 bar (600 psi)</li> </ul>	45 ms	<ul style="list-style-type: none"> <li>▪ 450 ms</li> <li>▪ 450 ms</li> <li>▪ 60 ms</li> <li>▪ 45 ms</li> <li>▪ 40 ms</li> <li>▪ 60 ms</li> <li>▪ 60 ms</li> </ul>	<ul style="list-style-type: none"> <li>▪ 1040 ms</li> <li>▪ 1040 ms</li> <li>▪ 138 ms</li> <li>▪ 104 ms</li> <li>▪ 92 ms</li> <li>▪ 138 ms</li> <li>▪ 138 ms</li> </ul>
		<ul style="list-style-type: none"> <li>▪ 160 bar (2 400 psi)</li> <li>▪ 250 bar (3 750 psi)</li> </ul>	50 ms	40 ms	90 ms
FMD77, FMD78	Max.	Dependent on the diaphragm seal			

**Dynamic behavior, digital output (HART electronics)**

A typical burst rate of 300 ms results in the following behavior:

Type		Sensor	Dead time (t <sub>1</sub> )	Dead time (t <sub>1</sub> ) + Time constant T63 (t <sub>2</sub> )	Dead time (t <sub>1</sub> ) + Time constant T90 (t <sub>3</sub> )
PMD75	Min.	<ul style="list-style-type: none"> <li>▪ 10 mbar (0.15 psi)</li> <li>▪ 30 mbar (0.45 psi)</li> <li>▪ 100 mbar (1.5 psi)</li> <li>▪ 500 mbar (7.5 psi)</li> <li>▪ 3 bar (45 psi)</li> <li>▪ 16 bar (240 psi)</li> <li>▪ 40 bar (600 psi)</li> <li>▪ 160 bar (2 400 psi)</li> <li>▪ 250 bar (3 750 psi)</li> </ul>	205 ms	<ul style="list-style-type: none"> <li>▪ 655 ms</li> <li>▪ 655 ms</li> <li>▪ 265 ms</li> <li>▪ 250 ms</li> <li>▪ 245 ms</li> <li>▪ 265 ms</li> <li>▪ 265 ms</li> <li>▪ 265 ms</li> <li>▪ 295 ms</li> <li>▪ 295 ms</li> </ul>	<ul style="list-style-type: none"> <li>▪ 1200 ms</li> <li>▪ 1200 ms</li> <li>▪ 298 ms</li> <li>▪ 264 ms</li> <li>▪ 252 ms</li> <li>▪ 298 ms</li> <li>▪ 298 ms</li> <li>▪ 298 ms</li> <li>▪ 300 ms</li> <li>▪ 300 ms</li> </ul>
		Max.	<ul style="list-style-type: none"> <li>▪ 10 mbar (0.15 psi)</li> <li>▪ 30 mbar (0.45 psi)</li> <li>▪ 100 mbar (1.5 psi)</li> <li>▪ 500 mbar (7.5 psi)</li> <li>▪ 3 bar (45 psi)</li> <li>▪ 16 bar (240 psi)</li> <li>▪ 40 bar (600 psi)</li> <li>▪ 160 bar (2 400 psi)</li> <li>▪ 250 bar (3 750 psi)</li> </ul>	1005 ms	<ul style="list-style-type: none"> <li>▪ 1455 ms</li> <li>▪ 1455 ms</li> <li>▪ 1065 ms</li> <li>▪ 1050 ms</li> <li>▪ 1045 ms</li> <li>▪ 1065 ms</li> <li>▪ 1065 ms</li> <li>▪ 1065 ms</li> <li>▪ 1095 ms</li> <li>▪ 1095 ms</li> </ul>
FMD77, FMD78	Max.	Dependent on the diaphragm seal			

*Reading cycle*

- Acyclic: max. 3/s, typical 1/s (depends on command # and number of preambles)
- Cyclic (burst): max. 3/s, typical 2/s

The device commands the BURST MODE function for cyclic value transmission via the HART communication protocol.

*Cycle time (update time)*

Cyclic (burst): min. 300 ms

**Dynamic behavior, PROFIBUS PA**

A typical PLC cycle time of 1 s results in the following behavior:

Type		Sensor	Dead time (t <sub>1</sub> )	Dead time (t <sub>1</sub> ) + Time constant T63 (t <sub>2</sub> )	Dead time (t <sub>1</sub> ) + Time constant T90 (t <sub>3</sub> )
PMD75	Min.	<ul style="list-style-type: none"> <li>■ 10 mbar (0.15 psi)</li> <li>■ 30 mbar (0.45 psi)</li> <li>■ 100 mbar (1.5 psi)</li> <li>■ 500 mbar (7.5 psi)</li> <li>■ 3 bar (45 psi)</li> <li>■ 16 bar (240 psi)</li> <li>■ 40 bar (600 psi)</li> </ul>	80 ms	<ul style="list-style-type: none"> <li>■ 530 ms</li> <li>■ 530 ms</li> <li>■ 140 ms</li> <li>■ 125 ms</li> <li>■ 120 ms</li> <li>■ 140 ms</li> <li>■ 140 ms</li> </ul>	<ul style="list-style-type: none"> <li>■ 1075 ms</li> <li>■ 1075 ms</li> <li>■ 173 ms</li> <li>■ 139 ms</li> <li>■ 127 ms</li> <li>■ 173 ms</li> <li>■ 173 ms</li> </ul>
	Max.	<ul style="list-style-type: none"> <li>■ 10 mbar (0.15 psi)</li> <li>■ 30 mbar (0.45 psi)</li> <li>■ 100 mbar (1.5 psi)</li> <li>■ 500 mbar (7.5 psi)</li> <li>■ 3 bar (45 psi)</li> <li>■ 16 bar (240 psi)</li> <li>■ 40 bar (600 psi)</li> </ul>	1280 ms	<ul style="list-style-type: none"> <li>■ 1730 ms</li> <li>■ 1730 ms</li> <li>■ 1340 ms</li> <li>■ 1325 ms</li> <li>■ 1320 ms</li> <li>■ 1340 ms</li> <li>■ 1340 ms</li> </ul>	<ul style="list-style-type: none"> <li>■ 2275 ms</li> <li>■ 2275 ms</li> <li>■ 1373 ms</li> <li>■ 1339 ms</li> <li>■ 1327 ms</li> <li>■ 1373 ms</li> <li>■ 1373 ms</li> </ul>
FMD77, FMD78	Max.	Dependent on the diaphragm seal			

*Reading cycle (SPS)*

- Acyclic: typically 25/s
- Cyclic: typically 30/s (dependent on the number and type of function blocks used in a closed-control loop)

*Cycle time (update time)*

Min. 200 ms

The cycle time in a bus segment in cyclic data communication depends on the number of devices, on the segment coupler used and on the internal PLC cycle time. A new measured value can be determined up to five times a second.

**Dynamic behavior, FOUNDATION Fieldbus**

A typical configuration for the macro cycle time (host system) of 1 s results in the following behavior:

Type		Sensor	Dead time ( $t_1$ )	Dead time ( $t_1$ ) + Time constant T63 ( $t_2$ )	Dead time ( $t_1$ ) + Time constant T90 ( $t_3$ )
PMD75	Min.	<ul style="list-style-type: none"> <li>■ 10 mbar (0.15 psi)</li> <li>■ 30 mbar (0.45 psi)</li> <li>■ 100 mbar (1.5 psi)</li> <li>■ 500 mbar (7.5 psi)</li> <li>■ 3 bar (45 psi)</li> <li>■ 16 bar (240 psi)</li> <li>■ 40 bar (600 psi)</li> </ul>	90 ms	<ul style="list-style-type: none"> <li>■ 540 ms</li> <li>■ 540 ms</li> <li>■ 150 ms</li> <li>■ 135 ms</li> <li>■ 130 ms</li> <li>■ 150 ms</li> <li>■ 150 ms</li> </ul>	<ul style="list-style-type: none"> <li>■ 1085 ms</li> <li>■ 1085 ms</li> <li>■ 183 ms</li> <li>■ 149 ms</li> <li>■ 137 ms</li> <li>■ 183 ms</li> <li>■ 183 ms</li> </ul>
	Max.	<ul style="list-style-type: none"> <li>■ 10 mbar (0.15 psi)</li> <li>■ 30 mbar (0.45 psi)</li> <li>■ 100 mbar (1.5 psi)</li> <li>■ 500 mbar (7.5 psi)</li> <li>■ 3 bar (45 psi)</li> <li>■ 16 bar (240 psi)</li> <li>■ 40 bar (600 psi)</li> </ul>	1090 ms	<ul style="list-style-type: none"> <li>■ 1540 ms</li> <li>■ 1540 ms</li> <li>■ 1150 ms</li> <li>■ 1135 ms</li> <li>■ 1130 ms</li> <li>■ 1150 ms</li> <li>■ 1150 ms</li> </ul>	<ul style="list-style-type: none"> <li>■ 2085 ms</li> <li>■ 2085 ms</li> <li>■ 1183 ms</li> <li>■ 1149 ms</li> <li>■ 1137 ms</li> <li>■ 1183 ms</li> <li>■ 1183 ms</li> </ul>
FMD77, FMD78	Max.	Dependent on the diaphragm seal			

*Reading cycle*

- Acyclic: typically 10/s
- Cyclic: max. 10/s (dependent on the number and type of function blocks used in a closed-control loop)

*Cycle time (update time)*

Cyclic: min. 100 ms

**Installation factors**

**Influence of installation position**

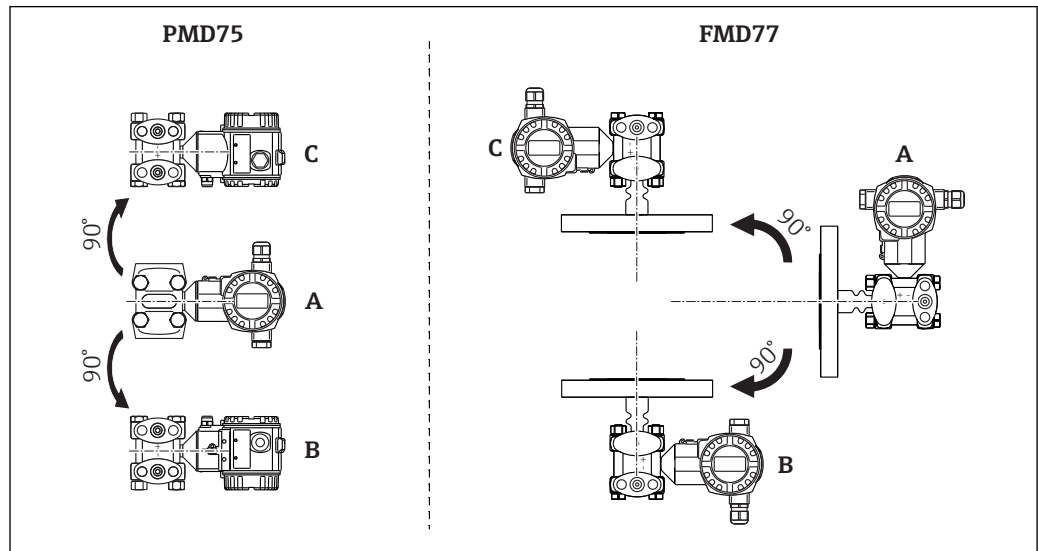

A0031035

Device	Calibration position (A)	Device rotated vertically downwards (B)	Device rotated vertically upwards (C)
PMD75 and silicone oil	No additional error	<+4 mbar (+0.06 psi) The value is doubled for inert oil.	<-4 mbar (-0.06 psi) The value is doubled for inert oil.
FMD77 and silicone oil	No additional error	<+32 mbar (+0.46 psi) The value is doubled for inert oil.	<-32 mbar (-0.46 psi) The value is doubled for inert oil.



A position-dependent zero point shift can be corrected. Please refer to the "Commissioning → Position adjustment" section of the Operating Instructions.

**Vibration effects**



Device/accessory	Measuring cells	Housing	Test standard	Vibration resistance
PMD75	10 mbar (0.15 psi), 30 mbar (0.45 psi)	T14 stainless steel T15 aluminum T17 aluminum	IEC 62828-1 / IEC 61298-3	≤ 0.15% URL to 10 to 38 Hz: ±0.35 mm (0.0138 in); 38 to 2000 Hz: 2 g in all 3 planes
		T14 aluminum	IEC 62828-1 / IEC 61298-3	≤ 0.15% URL to 10 to 60 Hz: ±0.21 mm (0.0083 in); 60 to 2000 Hz: 3 g in all 3 planes
	≥100 mbar (1.5 psi)	T14 stainless steel T15 aluminum	IEC 62828-1 / IEC 61298-3	≤ 0.075 % URL to 10 to 38 Hz: ±0.35 mm (0.0138 in); 38 to 2000 Hz: 2 g in all 3 planes
		T14 aluminum	IEC 62828-1 / IEC 61298-3	≤ 0.075 % URL to 10 to 60 Hz: ±0.35 mm (0.0138 in); 60 to 2000 Hz: 5 g in all 3 planes

**Warm-up period**

- 4 to 20 mA HART: < 10 s
- PROFIBUS PA: 6 s
- FOUNDATION Fieldbus: 50 s

## Installation

### General installation instructions

- A position-dependent zero point shift can be corrected directly at the device via operating keys, and also in hazardous areas in the case of devices with external operation.  
Diaphragm seals also shift the zero point, depending on the installation position →  98.
- The device housing can be rotated up to 380°.
- Endress+Hauser offers a mounting bracket for installing the device on pipes or walls →  35.
- Use flushing rings for flange and cell diaphragm seals if buildup or clogging can be expected at the diaphragm seal connection. The flushing ring can be fitted between the process connection and diaphragm seal. Material buildup in front of the process isolating diaphragm can be flushed away, and the pressure chamber vented, via the two lateral flushing holes.
- When measuring in media containing solids, such as dirty liquids, installing separators and drain valves is useful for capturing and removing sediment.
- Using a valve manifold allows for easy commissioning, installation and maintenance without interrupting the process.
- General recommendations for the pressure piping can be found in DIN 19210 "Methods for measurement of fluid flow; differential piping for flow measurement devices" or the corresponding national or international standards.
- Install the pressure piping with a continuous gradient of at least 10%.
- When routing the pressure piping outdoors, ensure sufficient anti-freeze protection, e.g. by using pipe heat tracing.
- Point the cable and connector downwards where possible to prevent moisture from entering (e.g. rain or condensation water).

### Measuring arrangement

#### Flow measurement

- The PMD75 is best suited to flow measurement.
- Measuring arrangement for gases: Mount device above the measuring point.
- Measuring arrangement for liquids and vapors: Mount device below the measuring point.
- For flow measurement in vapors, mount the condensate traps at the same level as the tapping point and at the same distance from the Deltabar S.

#### Level measurement

The PMD75 and FMD77 are best suited to level measurement in open vessels. All Deltabar S devices are suitable for level measurement in closed vessels.

Measuring arrangement for level measurement in open vessels

- PMD75: Mount device below the lower measuring connection. The negative side is open to atmospheric pressure.
- FMD77: Mount device directly on the vessel. The negative side is open to atmospheric pressure.

Measuring arrangement for level measurement in closed vessels and closed vessels with superimposed vapor

- PMD75: Mount device below the lower measuring connection. Always connect the negative side above the maximum level via pressure piping.
- FMD77: Mount device directly on the vessel. Always connect the negative side above the maximum level via pressure piping.
- In the case of level measurement in closed vessels with superimposed vapor, a condensate trap ensures the pressure remains constant on the negative side.

#### Pressure measurement

- The PMD75 and FMD78 are best suited to differential pressure measurement.
- Measuring arrangement for gases: Mount device above the measuring point.
- Measuring arrangement for liquids and vapors: Mount device below the measuring point.
- For differential pressure measurement in vapors, mount the condensate traps at the same level as the tapping point and at the same distance from the Deltabar S.

### Measuring arrangement for devices with diaphragm seals – FMD77 and FMD78

→  98

### Orientation

The orientation may cause a zero point shift.

This position-dependent zero point shift can be corrected directly at the device via the operating key, and also in hazardous areas in the case of devices with external operation (position adjustment).

**Wall and pipe mounting, transmitter (optional)**

Endress+Hauser offers the following mounting bracket for installing the device on pipes or walls:

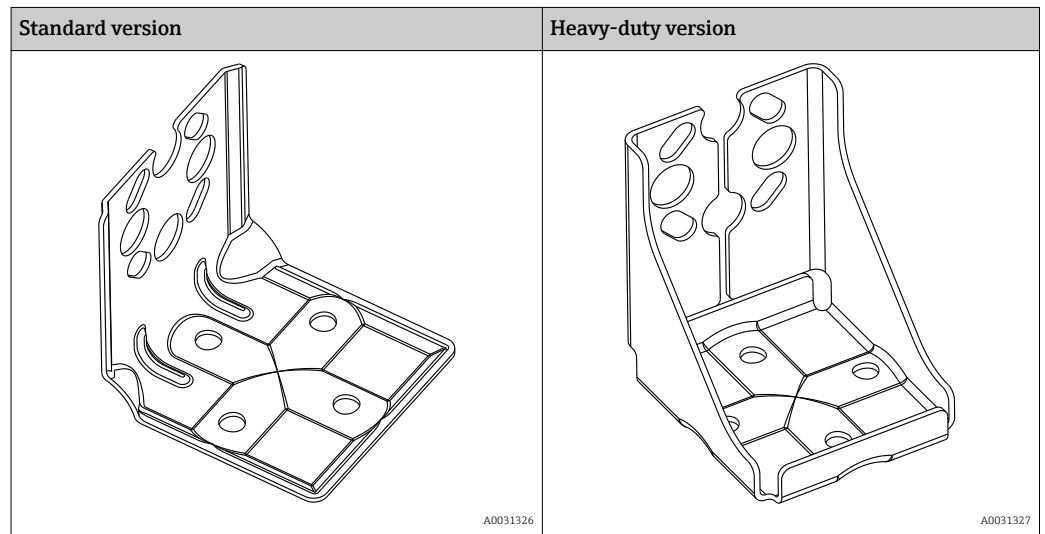

- The standard mounting bracket version is **not** suitable for use in an application subject to vibrations.
- The vibration resistance of the heavy-duty mounting bracket has been tested according to IEC 61298-3, see the "Vibration resistance" section → 39.
- If a valve manifold is used, its dimensions should also be taken into consideration.
- Bracket for wall and pipe mounting including retaining bracket for pipe mounting and two nuts.
- The material of the screws used to secure the device depend on the order code.
- For the technical data (such as the dimensions or order numbers for screws), see the document SD01553P/00/EN.

Ordering information:

- Standard version: Product Configurator, order code for "Additional options" option "Q" or
- Standard version: Product Configurator, order code for "Accessories enclosed" option "PD"
- Heavy-duty version: Product Configurator, order code for "Additional options" option "U" or
- Heavy-duty version: Product Configurator, order code for "Accessories enclosed" option "PB"

**Wall and pipe mounting, valve manifold (optional)**

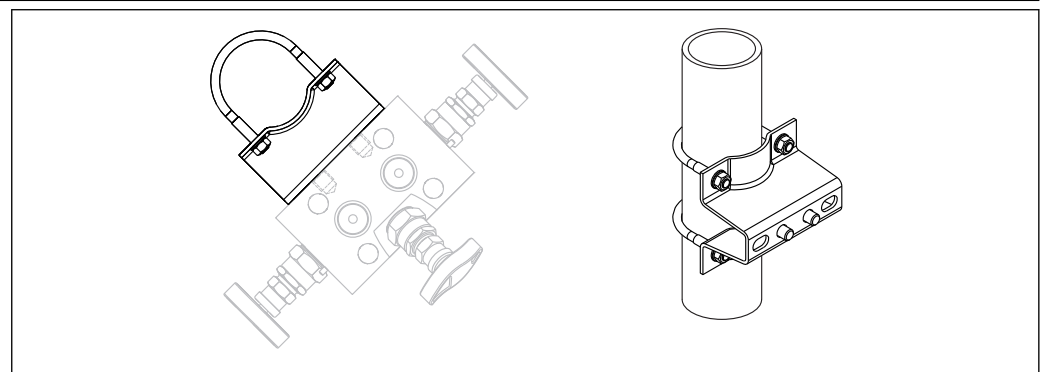

For the technical data (such as the dimensions or order numbers for screws), see the document SD01553P/00/EN.

Ordering information:

Product Configurator, order code for "Accessories enclosed", option "PJ"

**"Separate housing" version**

With the "separate housing" version, you are able to mount the housing with the electronics insert at a distance from the measuring point. This version facilitates trouble-free measurement

- Under particularly difficult measuring conditions (at installation locations that are cramped or difficult to access)
- If rapid cleaning of the measuring point is required and
- If the measuring point is exposed to vibrations.

You can choose between different cable versions:

- PE: 2 m (6.6 ft), 5 m (16 ft) and 10 m (33 ft)
- FEP: 5 m (16 ft).

Ordering information: Product Configurator, order code for "Additional options 2", version "G".

Dimensions →  46

In the case of the "separate housing" version, the sensor is delivered with the process connection and cable ready mounted. The housing and a mounting bracket are enclosed as separate units. The cable is provided with a socket at both ends. These sockets are simply connected to the housing and the sensor.

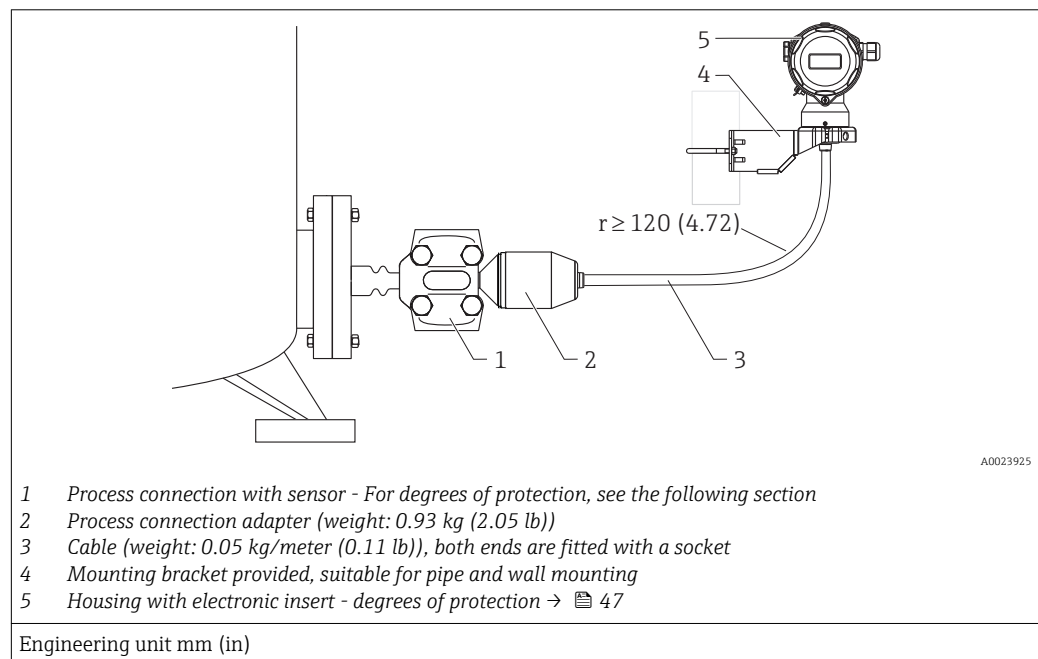

Degree of protection for the process connection and sensor with the use of

- FEP cable:
  - IP 69<sup>1)</sup>
  - IP 66 NEMA 4/6P
  - IP 68 (1.83 mH<sub>2</sub>O for 24 h) NEMA 4/6P
- PE cable:
  - IP 66 NEMA 4/6P
  - IP 68 (1.83 mH<sub>2</sub>O for 24 h) NEMA 4/6P

Technical data of the PE and FEP cable:

- Minimum bending radius: 120 mm (4.72 in)
- Cable extraction force: max. 450 N (101.16 lbf)
- Resistance to UV light

Use in hazardous area:

- Intrinsically safe installations (Ex ia/IS)
- FM/CSA IS: for Div. 1 installation only

1) Designation of the IP protection class according to DIN EN 60529. Previous designation "IP69K" according to DIN 40050 Part 9 is no longer valid (standard withdrawn on November 1, 2012). The tests required by both standards are identical.

### Reduction of the installation height

If the separate housing is used, the installation height of the process connection is reduced compared to the dimensions of the standard version.

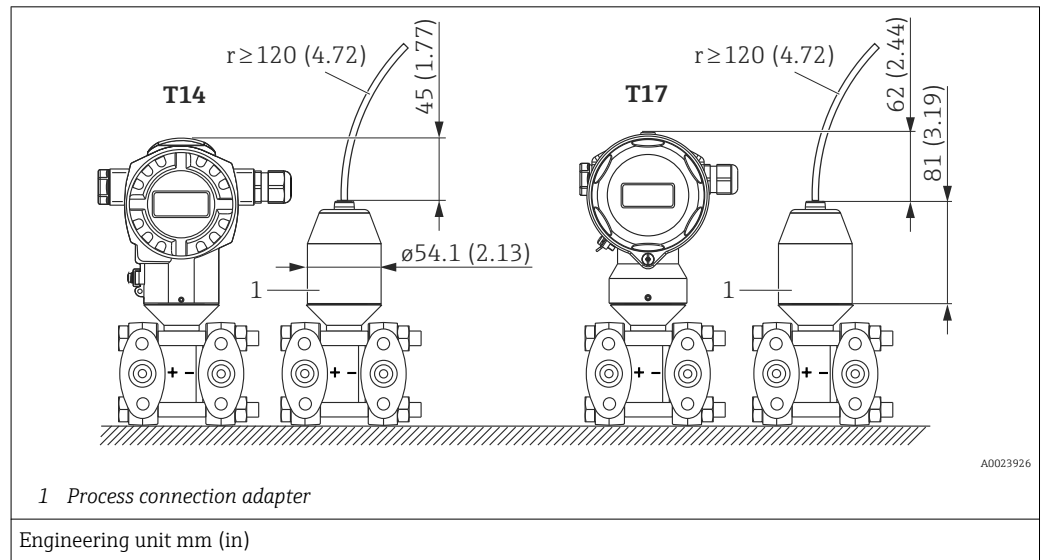

### Turning the housing

The housing can be rotated up to 380° by loosening the Allen screw.

#### Your benefits

- Easy mounting due to optimum alignment of housing
- Good, accessible device operation
- Optimum readability of the onsite display (optional).

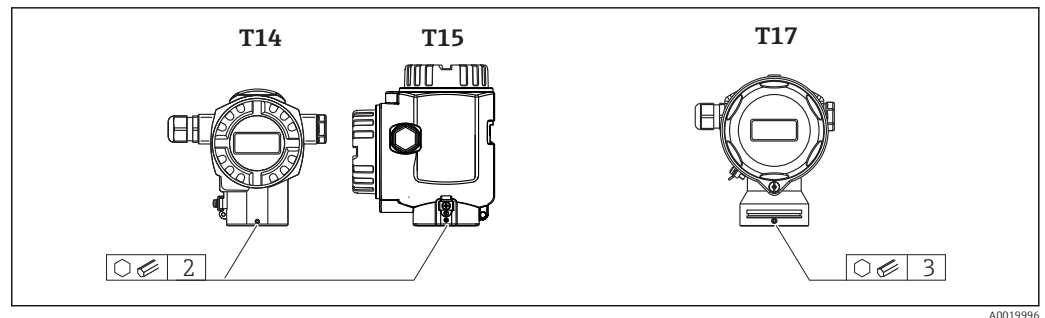

## Environment

### Ambient temperature range

Version	PMD75	FMD77	FMD78
Without LCD display	-50 to +85 °C (-58 to +185 °F) <sup>1)</sup> -54 to +85 °C (-65 to +185 °F) <sup>2)</sup>		
With LCD display <sup>3)</sup>	-20 to +70 °C (-4 to +158 °F)		
With separate housing	-	-20 to +60 °C (-4 to +140 °F)	
Diaphragm seal systems <sup>4)</sup>	-	→ ☰ 100	

- 1) If the temperature is below -40 °C (-40 °F), the chance of failure increases. Product Configurator, order code for "Test, Certificate" option "JN".
- 2) If the temperature is below -54 °C (-65 °F), the chance of failure increases. Product Configurator, order code for "Test, Certificate" option "JT".
- 3) Extended temperature application range (-50 to +85 °C (-58 to +185 °F)) with restrictions in optical properties, such as display speed and contrast
- 4) Ambient temperature range and process temperature range are mutually dependent - see "Heat insulation" section → ☰ 100

### PMD75: Ambient temperature $T_a$ as a function of process temperature $T_p$

For ambient temperatures below -40 °C (-40 °F), the process connection must be completely insulated.

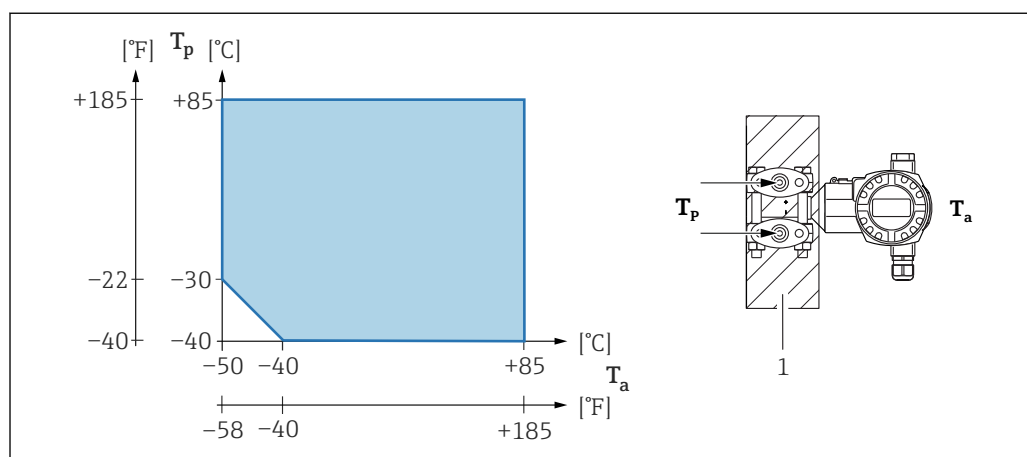

1 Insulation material

### Hazardous area

- For devices for use in hazardous areas, see Safety Instructions, Installation or Control Drawing → ☰ 114.
- Pressure measuring devices that have the usual explosion protection certificates (e.g. ATEX-/CSA-/FM-/IEC Ex,...) can be used in hazardous areas at ambient temperatures down to -50 °C (-58 °F) (order code for "Test, Certificate" option "JN"). The functionality of the explosion protection is also guaranteed for ambient temperatures down to -50 °C (-58 °F).
- Pressure measuring devices that have the usual explosion protection certificates (e.g. ATEX-/CSA-/FM-/IEC Ex,...) can be used in hazardous areas at ambient temperatures down to -54 to +85 °C (-65 to +185 °F) (order code for "Test, Certificate" option "JT"). The functionality of the explosion protection is also guaranteed for ambient temperatures down to -50 °C (-58 °F). At temperatures  $\leq -50$  °C (-58 °F), explosion protection is guaranteed by the housing in the case of flameproof enclosure (Ex d) type of protection. The functionality of the transmitter cannot be fully guaranteed.

**Storage temperature range**

- -40 to +90 °C (-40 to +194 °F)  
Option -50 to +90 °C (-58 to +194 °F) order code 580 "Test, Certificate" option "JN". If the temperature is below -40 °C (-40 °F), the probability of a failure increases.)  
Option -54 to +90 °C (-65 to +194 °F) order code 580 "Test, Certificate" option "JT". If the temperature is below -40 °C (-40 °F), the probability of a failure increases.)
- Local display: -40 to +85 °C (-40 to +185 °F)
- separate housing: -40 to +60 °C (-40 to +140 °F)
- Devices with PVC-armored capillary: -25 to +90 °C (-13 to +194 °F)

**Degree of protection**

Depends on the deployed

- housing: → ☰ 47
- separate housing: → ☰ 77

**Climate class**

Class 4K4H (air temperature: -20 to +55 °C (-4 to +131 °F), relative humidity: 4 to 100%) satisfied as per DIN EN 60721-3-4 (condensation possible)

**Electromagnetic compatibility**

- Electromagnetic compatibility as per EN 61326 and NAMUR recommendation EMC (NE21).
- With enhanced immunity against electromagnetic fields as per EN 61000-4-3: 30 V/m with closed cover (for devices with T14 housing or T15 housing)
- Maximum deviation: < 0.5 % of span
- All EMC measurements were performed with a turn down (TD) = 2:1.

For further details refer to the Declaration of Conformity.

**Vibration resistance**

Device/accessory	Measuring cells	Housing	Test standard	Vibration resistance
PMD75	10 mbar (0.15 psi), 30 mbar (0.45 psi)	T14 stainless steel T15 aluminum T17 aluminum	IEC 62828-1 / IEC 61298-3	Guaranteed for 10 to 38 Hz: ±0.35 mm (0.0138 in); 38 to 2000 Hz: 2 g in all 3 axes
		T14 aluminum	IEC 62828-1 / IEC 61298-3	Guaranteed for 10 to 60 Hz: ±0.21 mm (0.0083 in); 60 to 2000 Hz: 3 g in all 3 axes
	≥100 mbar (1.5 psi)	T14 stainless steel T15 aluminum	IEC 62828-1 / IEC 61298-3	Guaranteed for 10 to 38 Hz: ±0.35 mm (0.0138 in); 38 to 2000 Hz: 2 g in all 3 axes
		T14 aluminum	IEC 62828-1 / IEC 61298-3	Guaranteed for 10 to 60 Hz: ±0.35 mm (0.0138 in); 60 to 2000 Hz: 5 g in all 3 axes
With mounting bracket (heavy duty design)	All	All	IEC 62828-1 / IEC 61298-3	Guaranteed for 10 to 60 Hz: ±0.15 mm (0.0059 in); 60 to 500 Hz: 2 g in all 3 axes
FMD77	All	All	IEC 62828-1 / IEC 61298-3	Guaranteed for 10 to 60 Hz: ±0.075 mm (0.0030 in); 60 to 150 Hz: 1 g in all 3 axes

**Oxygen applications**

Oxygen and other gases can react explosively to oils, grease and plastics, such that, among other things, the following precautions must be taken:

- All components of the system, such as measuring devices, must be cleaned in accordance with the BAM requirements.
- Depending on the materials used, a certain maximum temperature and a maximum pressure must not be exceeded for oxygen applications.

The devices suitable for gaseous oxygen applications are listed in the following table with the specification  $p_{\max}$ .

HB = Cleaned for oxygen service

Order code for devices <sup>1)</sup> , cleaned for oxygen applications	$p_{\max}$ for oxygen applications	$T_{\max}$ for oxygen applications
PMD75 – * * * * * K * * or PMD75 – * * * * * H * * HB	160 bar (2 400 psi)	85 °C (185 °F)
PMD75 – * * * * * 2 * * or PMD75 – * * * * * A * * HB	160 bar (2 400 psi)	60 °C (140 °F)
PMD75 – * * * * * 3 * * or PMD75 – * * * * * C * * HB	160 bar (2 400 psi)	60 °C (140 °F)
FMD77 – * * * * * T * F * * or FMD77 – * * * * * D * F * * HB	PN of the flange	60 °C (140 °F)
FMD78 – * * * * * 4 * * or FMD78 – * * * * * 6 * * HB FMD78 – * * * * * D * * or FMD78 – * * * * * F * * HB	Depends on filling oil: max. 160 bar (2 400 psi)	85 °C (185 °F)

1) Devices only, not accessories or enclosed accessories.

**Ultrapure gas applications**

Endress+Hauser also offers devices for special applications, such as ultrapure gas, cleaned from oil and grease. No special restrictions regarding the process conditions apply to these devices.

Ordering information:

- PMD75: Product Configurator, order code for "Seal"
- FMD77: Product Configurator, order code for "Process connection low-pressure side; Material; Seal".

**Hydrogen applications**

A **gold-coated** metal process isolating diaphragm offers universal protection against hydrogen diffusion, both in gas applications and in applications with aqueous solutions.

**Applications with hydrogen in aqueous solutions**

A **gold/rhodium-coated** metal process isolating diaphragm (AU/Rh) offers effective protection against hydrogen diffusion.

**Operation in very corrosive environment**

Diaphragm seal FMD78 and FMD77 with capillary on low-pressure side:

For corrosive environments (e.g. maritime environment / coastal areas), Endress+Hauser recommends the use of a PVC or PTFE armor for the capillaries (→ 83). The transmitter can also be protected by a special coating (**Technical Special Product (TSP)**).

## Process

### Process temperature limits (temperature at transmitter)

#### PMD75

- Process connections made of 316L or Alloy C276: -50 to +85 °C (-58 to +185 °F)
- Process connections made of C22.8: -10 to +85 °C (+14 to +185 °F)
- For oxygen applications, see the → [40"Oxygen applications"](#) section.
- Pay attention to the process temperature range of the seal. See also the following section "Process temperature range, seals".

#### PMD75 with valve manifold

The maximum permitted process temperature at the manifold is 110 °C (230 °F).

For process temperatures >85 °C (185 °F)C where non-insulated side flanges are installed horizontally on a valve manifold, a reduced ambient temperature applies (see the following graphic).

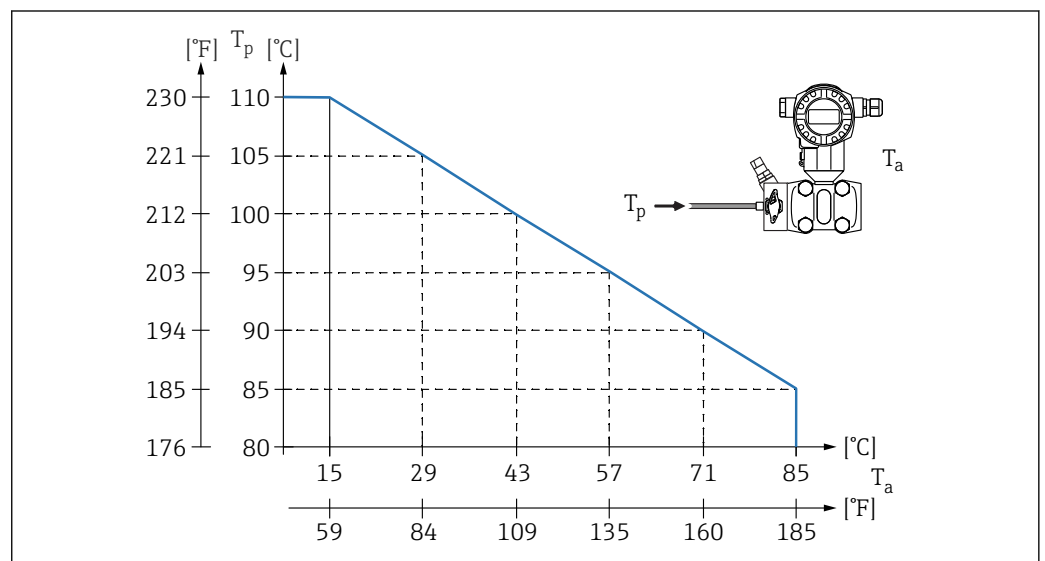

A0038812

$T_a$  Maximum ambient temperature at the manifold

$T_p$  Maximum process temperature at the manifold

#### FMD77

- Depends on the design (see the following table)
- Dependent on diaphragm seal and filling oil (→ [97](#)): -70 to +400 °C (-94 to +752 °F)
- For oxygen applications, see the → [40"Oxygen applications"](#) section.
- Pay attention to the process temperature range of the seal. See also the following section "Process temperature range, seals".
- Please observe the temperature application limits of the diaphragm seal oil. → [97](#), "Diaphragm seal filling oils" section.
- Please observe the maximum gauge pressure and maximum temperature.





Design	Temperature isolator	Temperature	Option <sup>1)</sup>
Transmitter horizontal	long	400 °C (752 °F)	MA
Transmitter vertical	long	300 °C (572 °F)	MR
Transmitter horizontal	short	200 °C (392 °F)	MC

Design	Temperature isolator	Temperature	Option <sup>1)</sup>
Transmitter vertical	short	200 °C (392 °F)	MD
U-bracket, Transmitter horizontal (for devices which require a CRN approval)	-	400 °C (752 °F)	<sup>2)</sup>

1) Product Configurator, order code for "Process connection"

2) In combination with CSA approval.

### FMD78

- Dependent on diaphragm seal and filling oil: -70 to +400 °C (-94 to +752 °F)
- For oxygen applications, see the →  "Oxygen applications" section.
- Please observe the temperature application limits of the diaphragm seal oil. →  97, "Diaphragm seal filling oils" section.
- Please observe the maximum gauge pressure and maximum temperature.

### FMD77 and FMD78: Devices with PTFE-coated process isolating diaphragm

The non-stick coating has excellent gliding properties and is used to protect the process isolating diaphragm against abrasive media.

#### NOTICE

#### Incorrect use of the PTFE foil will destroy the device!

- ▶ The PTFE foil is designed to protect the unit against abrasion. It does not provide protection against corrosive media.

#### Range of application of the PTFE foil

For the range of application of the 0.25 mm (0.01 in) PTFE foil on an AISI 316L (1.4404/1.4435) process isolating diaphragm, see the following diagram:

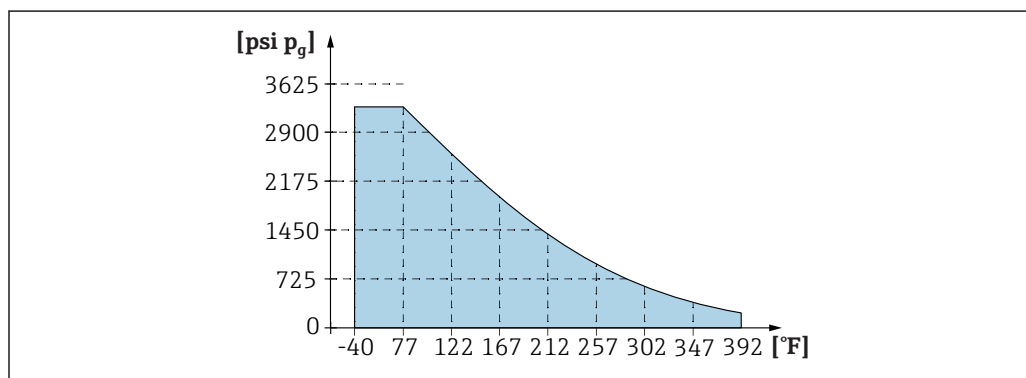

A0026949-EN

-  For vacuum applications:  $p_{\text{abs}} \leq 1 \text{ bar (14.5 psi)}$  to  $0.05 \text{ bar (0.725 psi)}$  up to max. +150 °C (302 °F).

- Process temperature limits of capillary armoring: FMD77 and FMD78**
- 316L: No restrictions
  - PTFE: No restrictions
  - PVC: See the following diagram

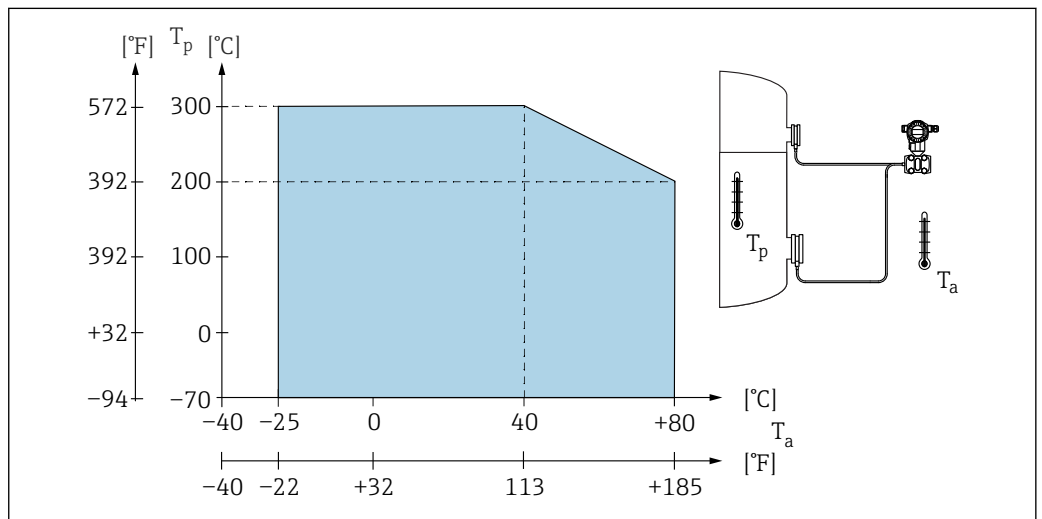



A0028096

**Process temperature range, seals** **PMD75**

Seal	Process temperature range	Option <sup>1)</sup>
FKM Viton	-20 to +110 °C (-4 to +230 °F) <sup>2)</sup>	A
PTFE	-40 to +110 °C (-40 to +230 °F) <sup>2)</sup>	C
NBR	-20 to +85 °C (-4 to +185 °F)	F
Copper	-40 to +85 °C (-40 to +185 °F)	H
Copper, cleaned for oxygen service	-20 to +85 °C (-4 to +185 °F)	K or H <sup>3)</sup>
FKM Viton, cleaned from oil and grease	-10 to +85 °C (+14 to +185 °F)	1
FKM Viton, cleaned for oxygen service	-10 to +60 °C (+14 to +140 °F)	2 or A <sup>3)</sup>
PTFE, cleaned for oxygen applications	-20 to +60 °C (-4 to +140 °F)	3 or C <sup>3)</sup>
EPDM <sup>4)</sup>	-40 to +85 °C (-40 to +185 °F)	J

- 1) Product Configurator, order code for "Seal"
- 2) For process temperatures > 85 °C (185 °F) pay attention to the ambient temperature and installation →  41
- 3) With option "HB", see Product Configurator, order code for "Service"
- 4) Always for LP side with blind flange (see Product Configurator, order code for "Process connection").

**FMD77 (with diaphragm seal)**



Seal on the LP side (-)	Process temperature range <sup>1)</sup>	OPL bar (psi)	PN bar (psi)	Option <sup>2)</sup>
FKM Viton	-20 to +85 °C (-4 to +185 °F)	See the "Measuring range" section "FMD77, FMD78, PMD75: Option PN 160 / 16 MPa / 2400 psi" →  12.		B, D, F, U
PTFE	-40 to +85 °C (-40 to +185 °F)			H, J
EPDM	-40 to +85 °C (-40 to +185 °F)			K, L
FKM Viton, cleaned from oil and grease	-10 to +85 °C (+14 to +185 °F)			S
FKM Viton, cleaned for oxygen service	-10 to +60 °C (+14 to +140 °F)			T or D <sup>3)</sup>
Kalrez, Compound 6375	0 to +5 °C (+32 to +41 °F)	44 to 49 (660 to 735)	29 to 33 (435 to 495)	M, N
	+5 to +10 °C (+41 to +50 °F)	49 to 160 (735 to 2400)	33 to 107 (495 to 1605)	
	+10 to +85 °C (+50 to +185 °F)	160 (2400)	107 (1605)	
Chemraz, Compound 505	-10 to +25 °C (+14 to +77 °F)	130 to 160 (1950 to 2400)	87 to 107 (1305 to 1605)	P, Q
	+25 to +85 °C (+77 to +185 °F)	160 (2400)	107 (1605)	
Diaphragm seal and capillary, welded	Please observe the temperature application limits of the diaphragm seal oil. →  97, "Diaphragm seal filling oils" section.			

- 1) Lower temperatures on request
- 2) Product Configurator, order code for "Process connection, LP side; seal."
- 3) With option "HB", see Product Configurator, order code for "Service"

## Pressure specifications

**⚠ WARNING**

**The maximum pressure for the measuring device depends on the lowest-rated element with regard to pressure.**

- ▶ For pressure specifications, see the "Measuring range" section and the "Mechanical construction" section.
- ▶ The measuring device must be operated only within the specified limits!
- ▶ MWP (maximum working pressure): The MWP (maximum working pressure) is specified on the nameplate. This value refers to a reference temperature of +20 °C (+68 °F) and may be applied to the device for an unlimited time. Observe the temperature dependency of the MWP. For the pressure values permitted at higher temperatures for flanges, please refer to standards EN 1092-1 (with regard to their stability-temperature property, the materials 1.4435 and 1.4404 are grouped together under EN 1092-1; the chemical composition of the two materials can be identical.), ASME B 16.5a, JIS B 2220 (the latest version of the standard applies in each case).
- ▶ The test pressure corresponds to the over pressure limit of the individual sensors (OPL = 1.5 x MWP) and may be applied only for a limited period of time to prevent any lasting damage.
- ▶ The Pressure Equipment Directive (2014/68/EU) uses the abbreviation "PS". The abbreviation "PS" corresponds to the MWP (maximum working pressure) of the measuring device.
- ▶ In the case of sensor range and process connections where the over pressure limit (OPL) of the process connection is smaller than the nominal value of the sensor, the device is set at the factory, at the very maximum, to the OPL value of the process connection. If you want to use the entire sensor range, select a process connection with a higher OPL value (1.5 x PN; MWP = PN)
- ▶ In oxygen applications, the values for  $p_{max}$  and  $T_{max}$  for oxygen applications must not be exceeded →  40.
- ▶ For the PMD75, the MWP applies to the temperature ranges specified in the "Ambient temperature range" →  38 and "Process temperature limits" →  41 sections.

**Burst pressure**

Device	Measuring range	Burst pressure <sup>1)</sup>
PMD75 PN160	≤40 bar (580 psi)	690 bar (10 005 psi) <sup>2)</sup>
PMD75 PN420	≤40 bar (580 psi)	1 600 bar (23 200 psi) <sup>2) 3) 4)</sup>

- 1) Excluding FMD77 and FMD78 with mounted diaphragm seal systems
- 2) Applies for the process seal materials FKM, PTFE, NBR, EPDM and for pressure applied on both sides.
- 3) If the side vent valves (sv) option is selected, the burst pressure is 690 bar (10 005 psi)
- 4) For the process seal material PTFE (PN250), the burst pressure is 1 250 bar (18 125 psi)

## Mechanical construction

 For the dimensions, see the Product Configurator: [www.endress.com](http://www.endress.com)

Search for product → click "Configuration" to the right of the product image → after configuration click "CAD"



The following dimensions are rounded values. For this reason, they may deviate slightly from the dimensions given on [www.endress.com](http://www.endress.com).

### Device height

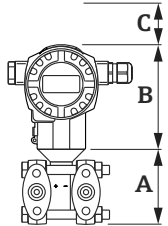

The device height is calculated from

- the height of the housing
- the height of optional mounted parts such as temperature isolators or capillaries
- the height of the relevant process connection.

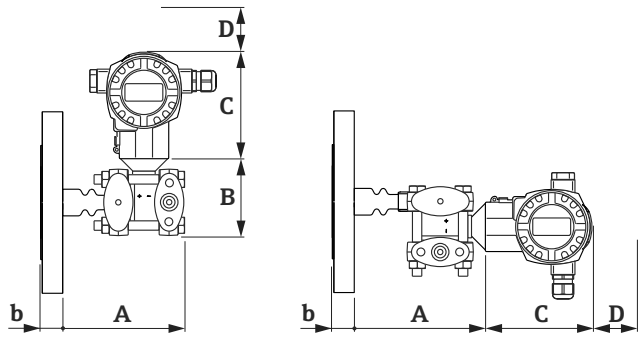

The individual heights of the components can be found in the following sections. To calculate the device height, simply add up the individual heights of the components. If necessary, the installation space (the space used to install the device) must also be taken into account. You can use the following table for this:

Designation	Item	Dimension	Example with PMD75
Side flanges	(A)	85 mm (3.35 in)	
Height of housing	(B)	→  47 ff.	
Installation space	(C)	-	
Device height			

A0023927

Designation	Item	Dimension	Example with FMD77
Mounted parts	(A)	→  54	
Side flanges	(B)	85 mm (3.35 in)	
Height of housing	(C)	→  47 ff.	
Installation space	(D)	-	
Process connections	(b)	→  49	
Device height			

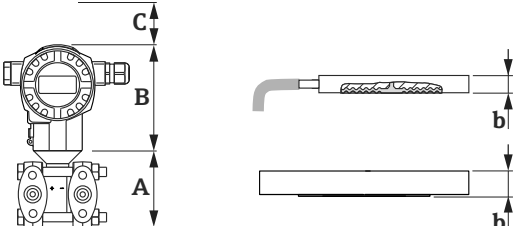
A0025880

Designation	Item	Dimension	Example with FMD78
Side flanges	(A)	85 mm (3.35 in)	
Height of housing	(B)	→  47 ff.	
Installation space	(C)	-	
Process connections	(b)	→  49	
Device height			

A0025881

**T14 housing, optional display on the side**

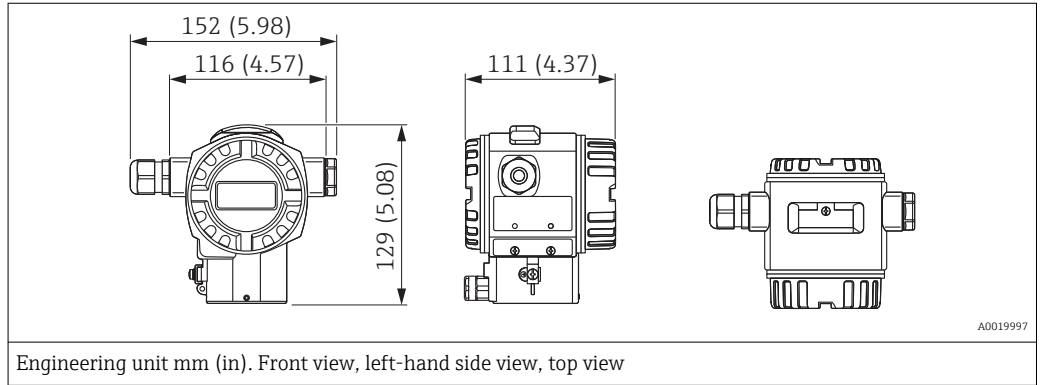

Material		Degree of protection	Cable entry	Weight in kg (lb)		Option <sup>1)</sup>
Housing	Cover seal			with display	without display	
Aluminum	EPDM	IP66/67 NEMA 6P	M20 gland	1.2 (2.65)	1.1 (2.43)	A
		IP66/67 NEMA 6P	G ½" thread			B
		IP66/67 NEMA 6P	NPT ½" thread			C
		IP66/67 NEMA 6P	M12 plug			D
		IP66/67 NEMA 6P	7/8" plug			E
		IP65 NEMA 4	HAN7D plug 90 degrees			F
316L	EPDM	IP66/67 NEMA 6P	M20 gland	2.1 (4.63)	2.0 (4.41)	1
		IP66/67 NEMA 6P	G ½" thread			2
		IP66/67 NEMA 6P	NPT ½" thread			3
		IP66/67 NEMA 6P	M12 plug			4
		IP66/67 NEMA 6P	7/8" plug			5
		IP65 NEMA 4	HAN7D plug 90 degrees			6
	FVMQ	IP66/67 NEMA 6P	M20 gland	7		
	FVMQ	IP66/67 NEMA 6P	NPT ½" thread	8		

1) Product Configurator, order code for "Housing, cover seal, cable entry, degree of protection"

**T15 housing, optional display on the top**

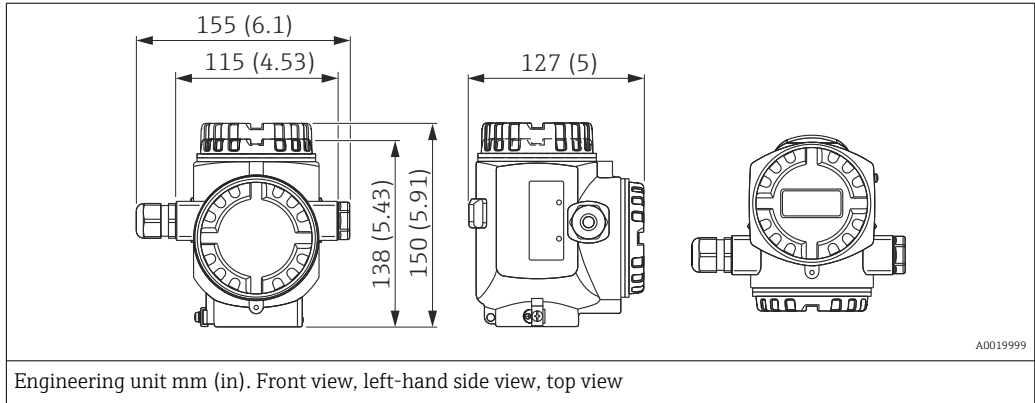

Material		Degree of protection	Cable entry	Weight in kg (lb)		Option <sup>1)</sup>
Housing	Cover seal			with display	without display	
Aluminum	EPDM	IP66/67 NEMA 6P	M20 gland	1.8 (3.97)	1.7 (3.75)	J
		IP66/67 NEMA 6P	G ½" thread			K
		IP66/67 NEMA 6P	NPT ½" thread			L
		IP66/67 NEMA 6P	M12 plug			M
		IP66/67 NEMA 6P	7/8" plug			N
		IP65 NEMA 4	HAN7D plug 90 degrees			P

1) Product Configurator, order code for "Housing, cover seal, cable entry, degree of protection"

**T17 housing (hygienic), optional display on the side**

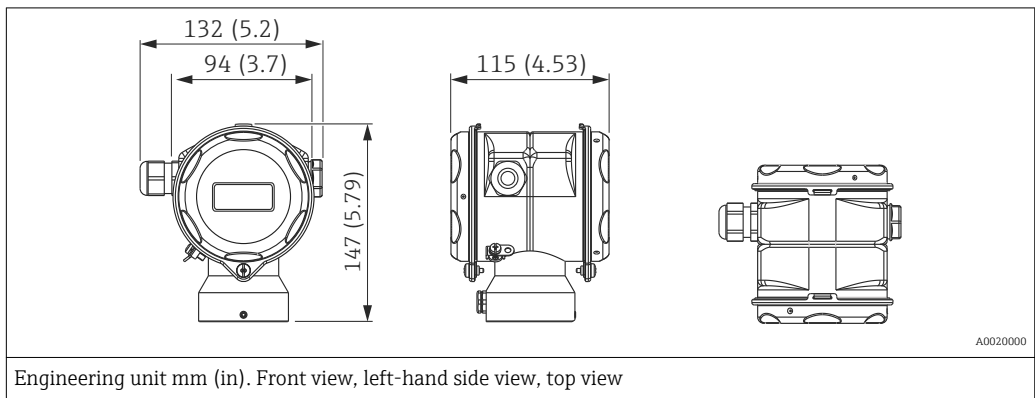

Material		Degree of protection <sup>1)</sup>	Cable entry	Weight in kg (lb)		Option <sup>2)</sup>
Housing	Cover seal			with display	without display	
316L	EPDM	IP66/68 NEMA 6P	M20 gland	1.2 (2.65)	1.1 (2.43)	R
		IP66/68 NEMA 6P	G ½" thread			S
		IP66/68 NEMA 6P	NPT ½" thread			T
		IP66/68 NEMA 6P	M12 plug			U
		IP66/68 NEMA 6P	7/8" plug			V

1) Degree of protection IP 68: 1.83 mH<sub>2</sub>O for 24 h

2) Product Configurator, order code for "Housing, cover seal, cable entry, degree of protection"

Process connections PMD75 Oval flange, connection 1/4-18 NPT or RC 1/4

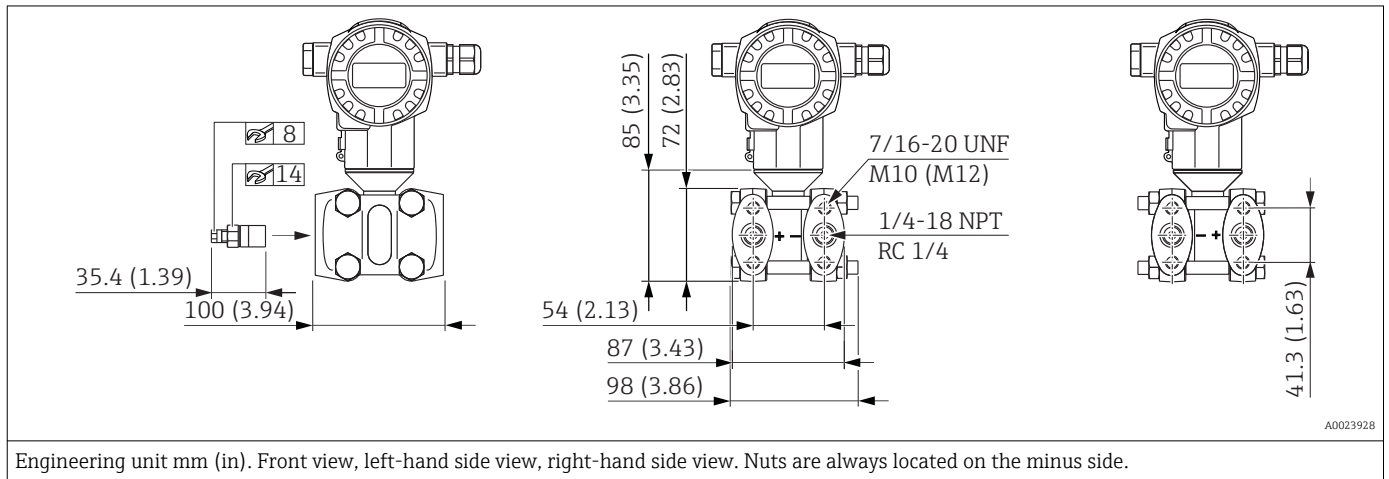

Connection	Mounting	Material	Accessories	Weight <sup>1)</sup>	Option <sup>2)</sup>
				kg (lbs)	
1/4-18 NPT IEC 61518	7/16-20 UNF	Steel C 22.8 (1.0460/Zn5) <sup>3)</sup>	incl. 2 vent valves AISI 316L (1.4404)	4.2 (9.26)	B
1/4-18 NPT IEC 61518	7/16-20 UNF	1.4408 / CF3M <sup>4)</sup> / AISI 316L AISI 316L (1.4404) <sup>5)</sup>			D
1/4-18 NPT IEC 61518	7/16-20 UNF	Alloy C276 (2.4819)	Vent valves Alloy C276 (2.4819) <sup>6)</sup>	4.5 (9.92)	F
RC 1/4	7/16-20 UNF	1.4408 / CF3M <sup>4)</sup> / AISI 316L AISI 316L (1.4404) <sup>5)</sup>	incl. 2 vent valves AISI 316L (1.4404)	4.2 (9.26)	U
1/4-18 NPT IEC 61518	▪ PN 160: M10 ▪ PN 420: M12	Steel C 22.8 (1.0460/Zn5) <sup>3)</sup>			1
1/4-18 NPT IEC 61518	▪ PN 160: M10 ▪ PN 420: M12	AISI 316L (1.4404)			2
1/4-18 NPT IEC 61518	▪ PN 160: M10 ▪ PN 420: M12	Alloy C276 (2.4819)	Vent valves Alloy C276 (2.4819) <sup>6)</sup>	4.5 (9.92)	3
HP: 1/4-18 NPT IEC 61518 LP: blind flange	7/16-20 UNF	AISI 316L (1.4404)	incl. vent valve AISI 316L (1.4404)	4.2 (9.26)	Q
HP: 1/4-18 NPT IEC 61518 LP: blind flange	7/16-20 UNF	Alloy C276 (2.4819)	without vent valve <sup>6)</sup> .	4.5 (9.92)	S

- 1) Weight of process connections without vent valves with 10 mbar (0.15 psi) or 30 mbar (0.45 psi) measuring cell, process connections without vent valves with measuring cells  $\geq 100$  mbar (1.5 psi) weigh approx. 800 g (28.22 oz) less.
- 2) Product Configurator, order code for "Process connection"
- 3) The C22.8 side flanges are coated with anti-corrosion protection (zinc, chrome). To prevent the formation of hydrogen and thereby diffusion through the membrane, Endress+Hauser recommends the use of 316L side flanges for applications involving water. Hydrogen diffusion through the diaphragm leads to measurement errors, or in extreme cases to a device failure.
- 4) Cast equivalent to material AISI 316L
- 5) For devices with CSA approval: Product Configurator, order code for "Approval", options D, E, F, U, V, W and X
- 6) Product Configurator, order code for "Additional options 2"

## Process connections PMD75 Oval flange, connection 1/4-18 NPT or RC 1/4, with side vent

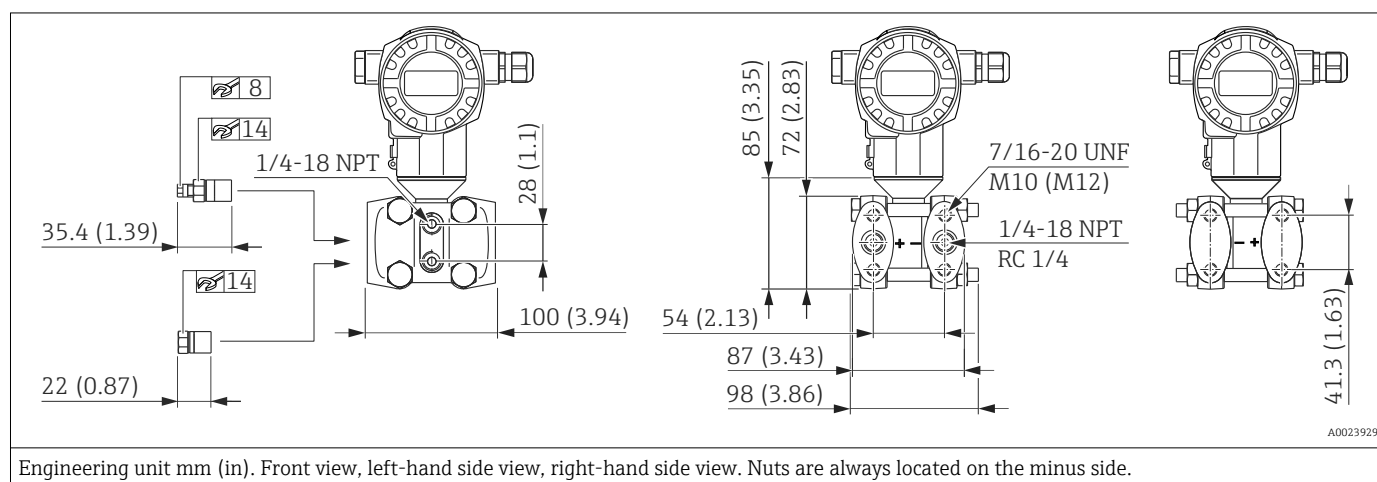

Connection	Mounting	Material	Accessories	Weight <sup>1)</sup>	Option <sup>2)</sup>
				kg (lbs)	
1/4-18 NPT IEC 61518	7/16-20 UNF	Steel C 22.8 (1.0460/Zn5) <sup>3)</sup>	4 locking screws and 2 vent valves AISI 316L (1.4404)	4.2 (9.26)	C
1/4-18 NPT IEC 61518	7/16-20 UNF	1.4408 / CF3M <sup>4)</sup> / AISI 316L AISI 316L (1.4404) <sup>5)</sup>			E
1/4-18 NPT IEC 61518	7/16-20 UNF	Alloy C276 (2.4819)	Vent valves Alloy C276 (2.4819) <sup>6)</sup>	4.5 (9.92)	H
RC 1/4	7/16-20 UNF	1.4408 / CF3M <sup>4)</sup> / AISI 316L AISI 316L (1.4404) <sup>5)</sup>	4 locking screws and 2 vent valves AISI 316L (1.4404)	4.2 (9.26)	V
HP: 1/4-18 NPT IEC 61518 LP: blind flange	7/16-20 UNF	AISI 316L (1.4404)	incl. locking screws and vent valve AISI 316L (1.4404)	4.2 (9.26)	R
HP: 1/4-18 NPT IEC 61518 LP: blind flange	7/16-20 UNF	Alloy C276 (2.4819)	Vent valve Alloy C276 (2.4819) <sup>6)</sup>	4.5 (9.92)	T

- 1) Weight of process connections without vent valves with 10 mbar (0.15 psi) or 30 mbar (0.45 psi) measuring cell, process connections without vent valves with measuring cells  $\geq 100$  mbar (1.5 psi) weigh approx. 800 g (28.22 oz) less.
- 2) Product Configurator, order code for "Process connection"
- 3) The C22.8 side flanges are coated with anti-corrosion protection (zinc, chrome). To prevent the formation of hydrogen and thereby diffusion through the membrane, Endress+Hauser recommends the use of 316L side flanges for applications involving water. Hydrogen diffusion through the diaphragm leads to measurement errors, or in extreme cases to a device failure.
- 4) Cast equivalent to material AISI 316L
- 5) For devices with CSA approval: Product Configurator, order code for "Approval", options D, E, F, U, V, W and X
- 6) Product Configurator, order code for "Additional options 2"

Process connections PMD75 Oval flange, prepared for diaphragm seal mount

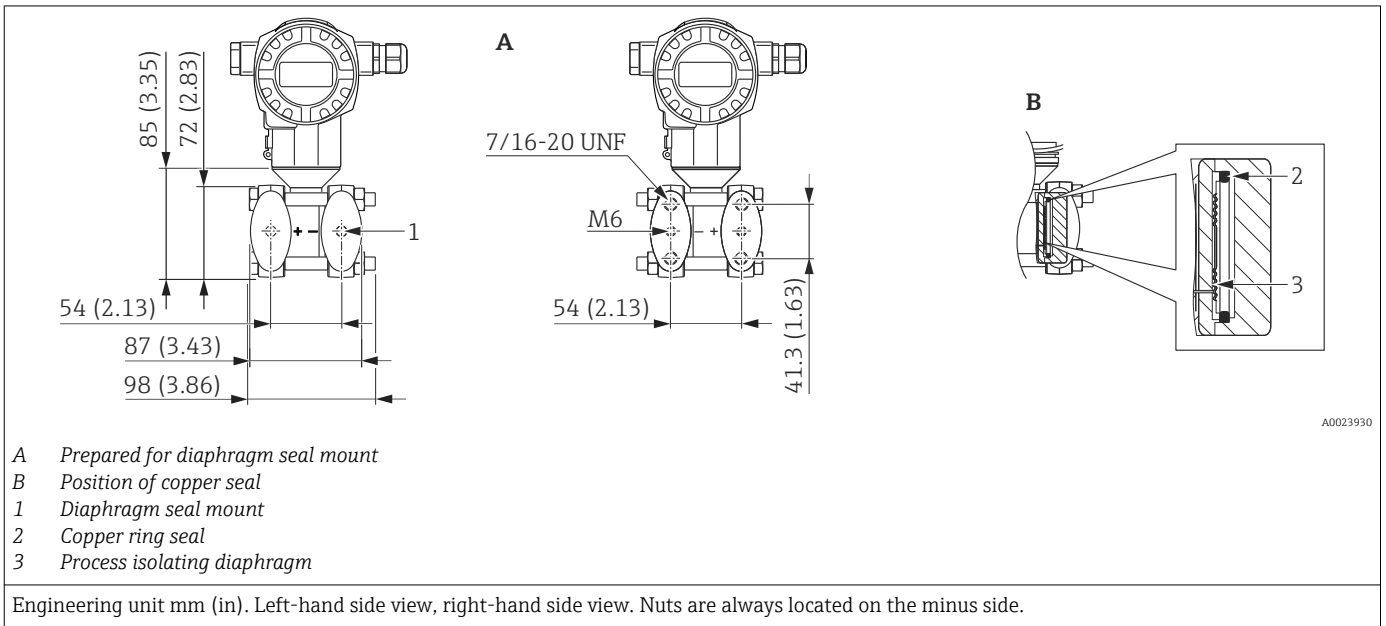

Material	Option <sup>1)</sup>
1.4408 / CF3M <sup>2)</sup> / AISI 316L	W
AISI 316L (1.4404) <sup>3)</sup>	

- 1) Product Configurator, order code for "Process connection"
- 2) Cast equivalent to material AISI 316L
- 3) For devices with CSA approval: Product Configurator, order code for "Approval", options D, E, F, U, V, W and X

**Valve manifold DA63M-  
(optional)**

Endress+Hauser supplies milled valve manifolds via the transmitter's product structure in the following versions:

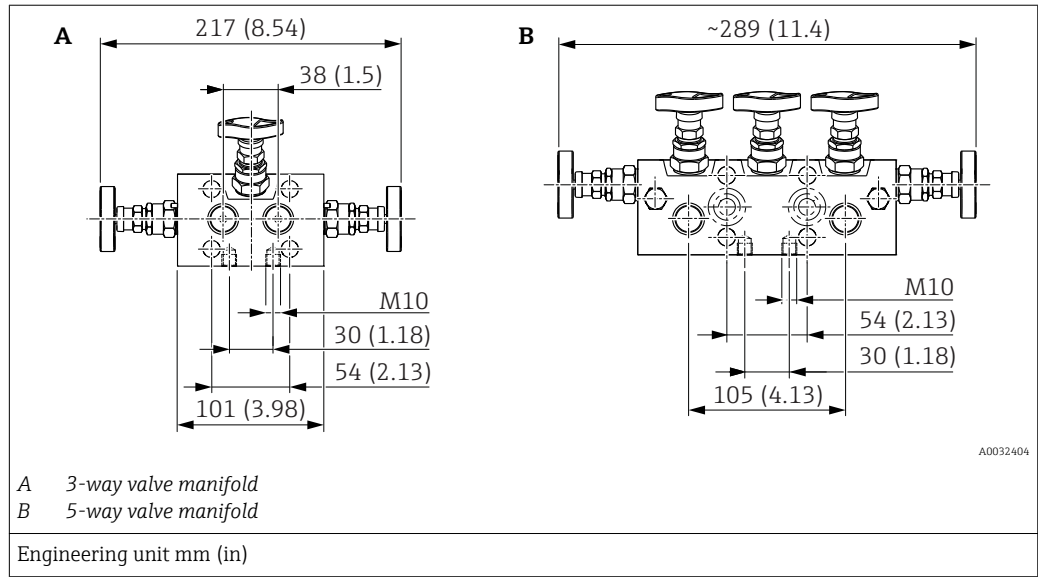

- 3-way or 5-way valve manifolds in 316L or AlloyC can be
- ordered as an **enclosed** accessory (screws and seals for mounting are enclosed)
  - ordered as a **mounted** accessory (mounted valve manifolds are supplied with a documented leakage test).

Certificates ordered with the equipment (e.g. 3.1 material certificate and NACE) and tests (e.g. PMI and pressure test) apply to the transmitter and the valve manifold.

For other details (order option, dimension, weight, materials), see SD01553P/00/EN "Mechanical accessories for pressure measuring devices".

During the operating life of the valves, it may be necessary to re-tighten the packing.

**Mounting on valve manifold**

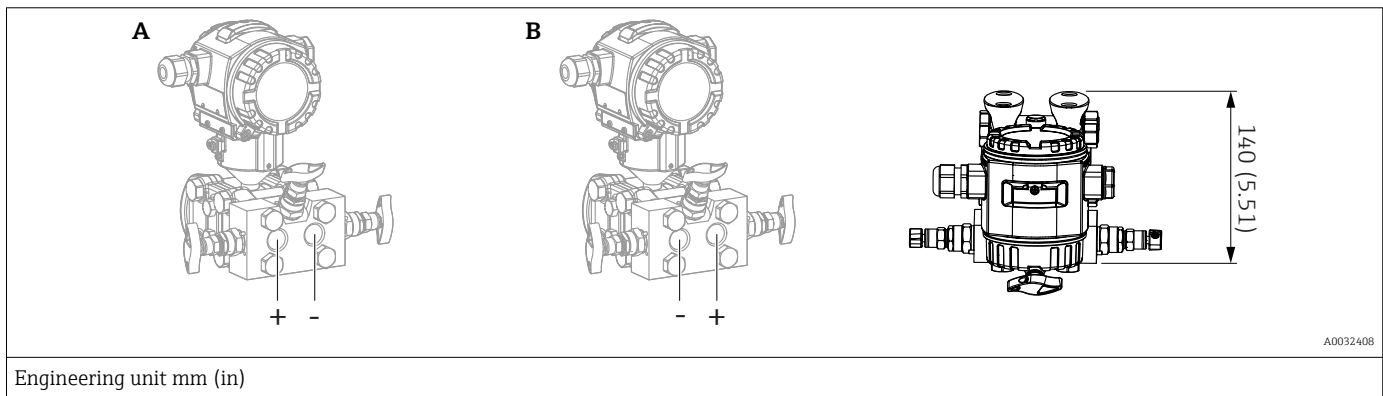

Item	Designation	Option <sup>1)</sup>
A	Mounting from above on valve manifold	NV
B	Mounting from below on valve manifold	NW

1) Product Configurator, order code for "Accessories mounted"

**FMD77: Selecting the process connection and capillary line**

The device can be fitted with different process connections on the high-pressure side (HP) and on the low-pressure side (LP).

The FMD77 can also be fitted with capillary lines on the low-pressure side (LP).

When using diaphragm seal systems with a capillary, sufficient strain relief must be provided to prevent the capillary from bending (capillary bending radius  $\geq 100$  mm (3.94 in)).

**Example:**

- Process connection on high-pressure side = DN80 flange
- Process connection on low-pressure side = DN50 flange

**Your benefits:**

- Thanks to the variety of order options, the devices can be optimally adapted to the given installation situation
- Reduced costs due to optimum system design
- Easier installation due to adjusted length of capillary line
- Easier adaptation to existing installation situations

**Ordering information:**

- Process connections are indicated in the relevant section by HP (high-pressure side) and LP (low-pressure side)
- Order details for capillary lengths → 85

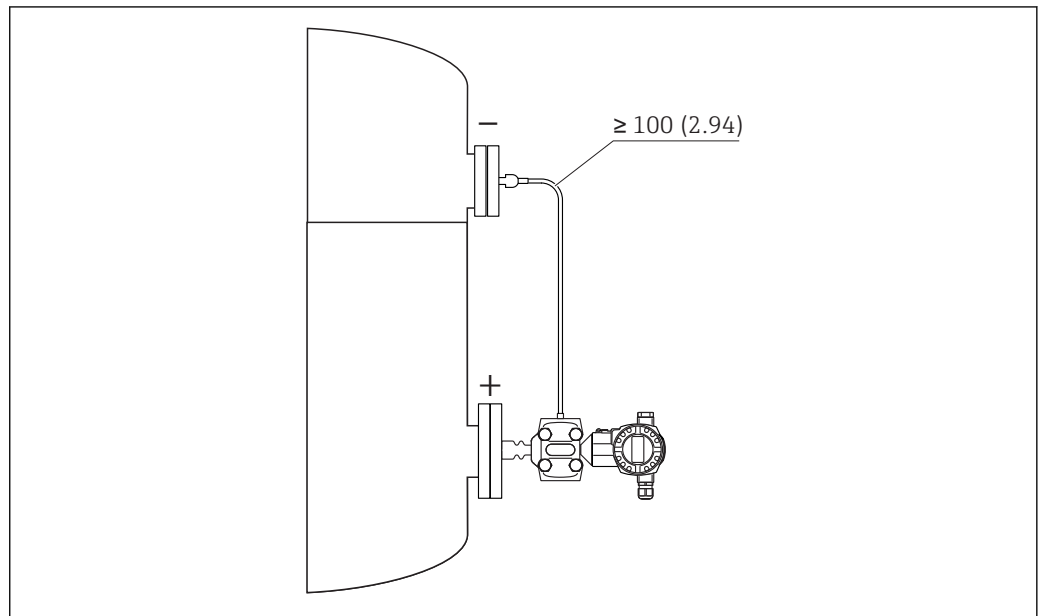

A0027889

- i** Due to the use of different process connections and capillary lines, it is essential that the device be designed/ordered using the "Applicator Sizing Diaphragm Seal" selection tool, which is available free of charge. Additional information can be found in the "Planning instructions, diaphragm seal systems" section → 94

FMD77 - Overview

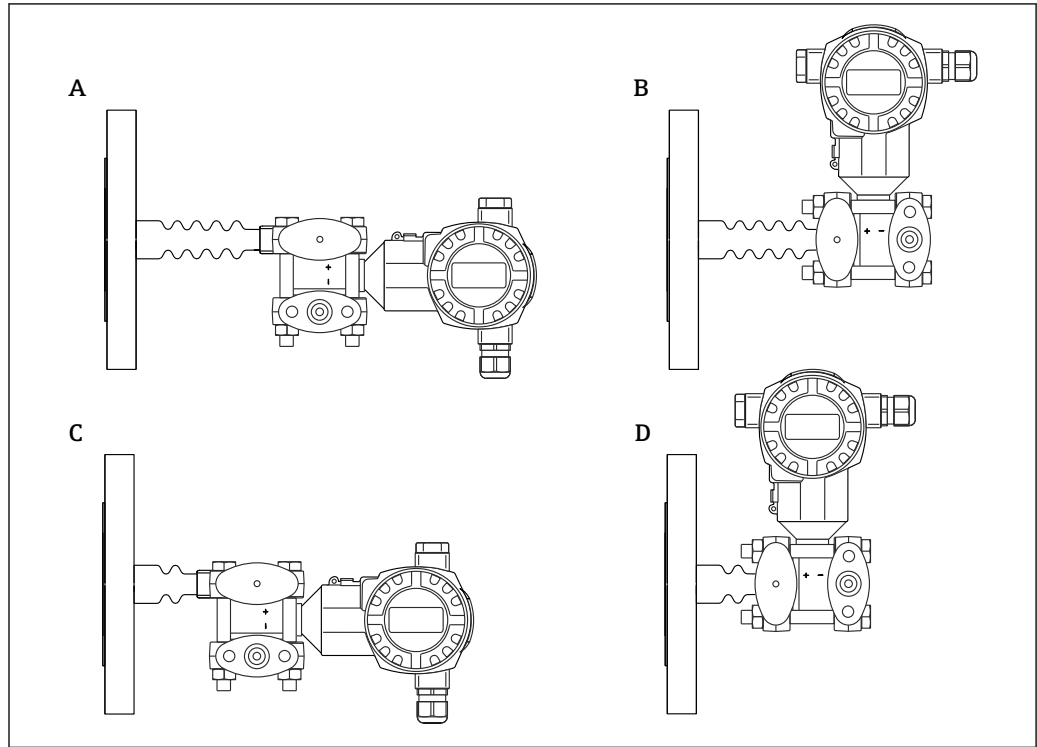

A0025157

Item	Design	Temperature isolator	Page	Option <sup>1)</sup>
A	Transmitter horizontal	long	→ 55	MA <sup>2)</sup>
B	Transmitter vertical	long	→ 55	MB
C	Transmitter horizontal	short	→ 55	MC
D	Transmitter vertical	short	→ 55	MD

- 1) Product Configurator, order code for "Design; temperature isolator"
- 2) Standard

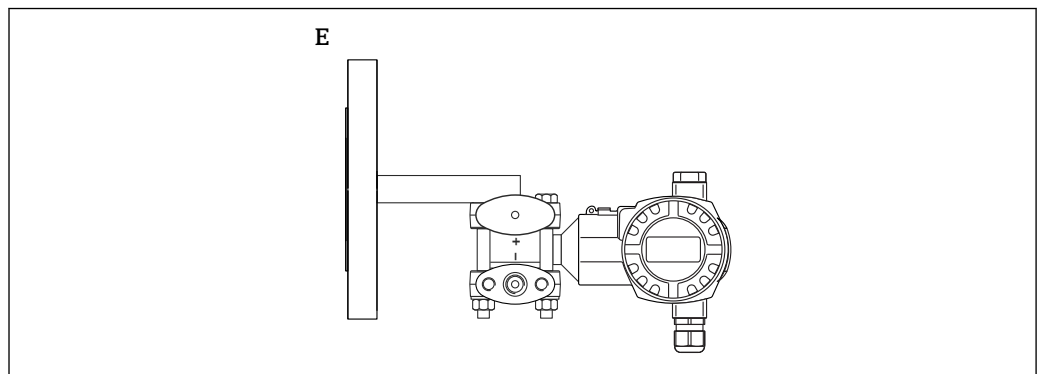

A0025252

Item	Design	Page	Option <sup>1)</sup>
E	U-bracket, Transmitter horizontal (for devices which require a CRN approval)	→ 56	In combination with CSA approval.

- 1) Product Configurator, order code for "Process connection"

**Process connections FMD77  
with diaphragm seal, high-  
pressure side**

**Device with long temperature isolator**

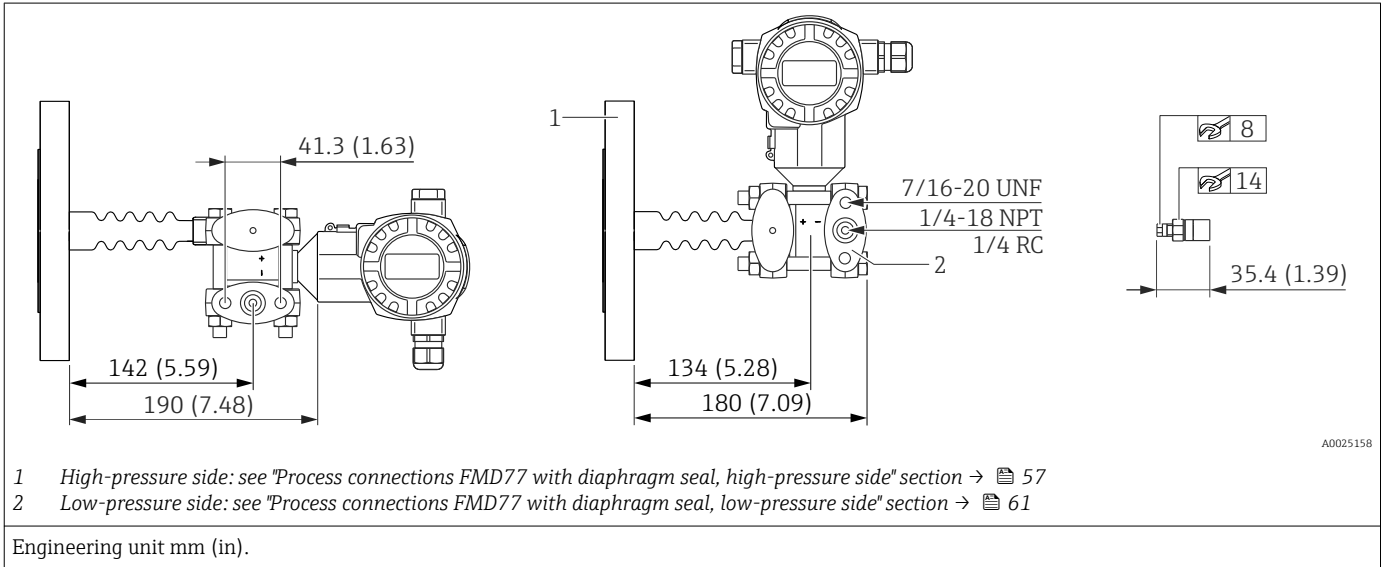

**Device with short temperature isolator**

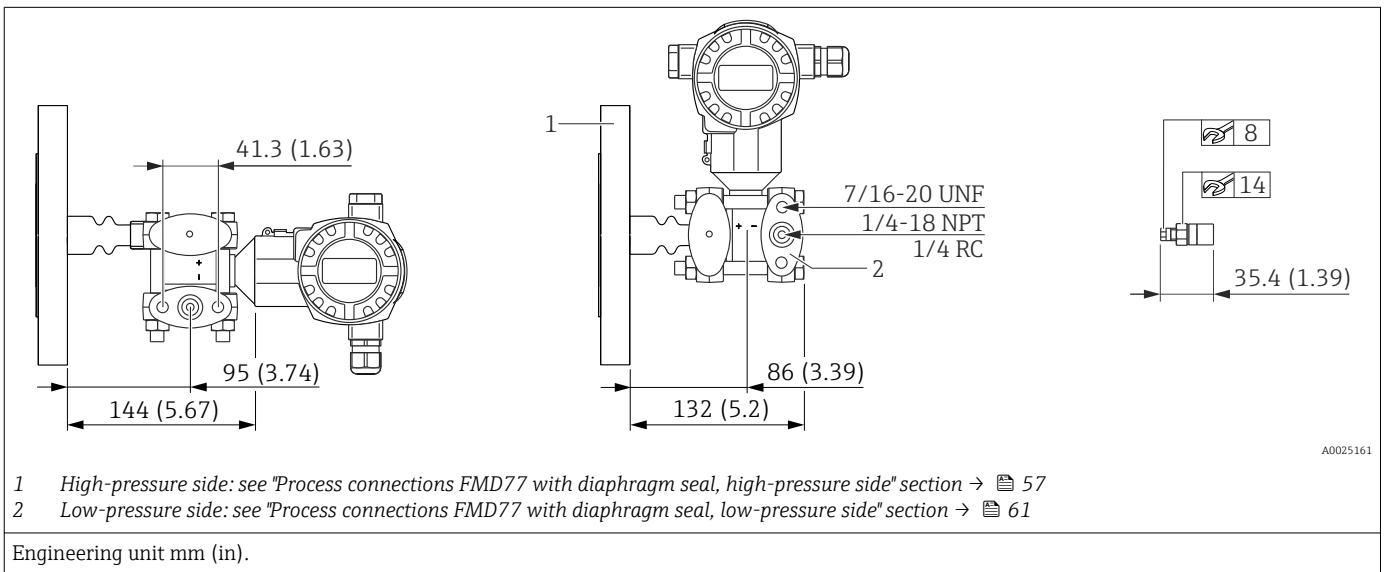

**Process connections FMD77  
with diaphragm seal, high-  
pressure side**

**U-bracket with CRN approval**

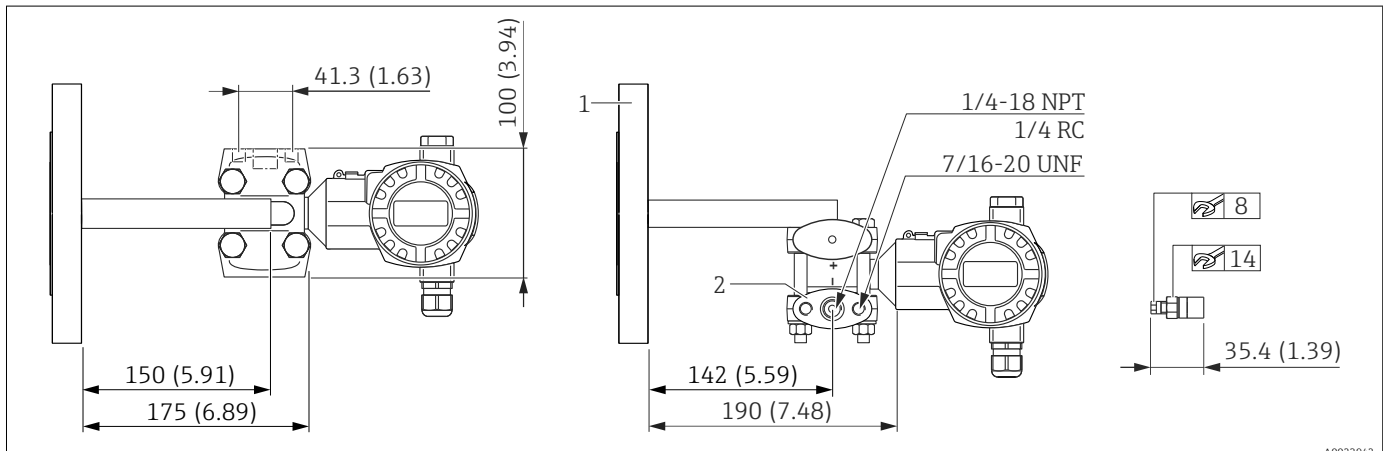

A0023942

- 1 High-pressure side: see "Process connections FMD77 with diaphragm seal, high-pressure side" section → 57
- 2 Low-pressure side: see "Process connections FMD77 with diaphragm seal, low-pressure side" section → 61

Engineering unit mm (in).

**Process connections FMD77 with diaphragm seal**



- The following drawings are drawings that illustrate how the system works in principle. In other words, the dimensions of a diaphragm seal supplied can deviate from the dimensions given in this document.
- Observe the information in the "Planning instructions for diaphragm seal systems" section → 94
- For further information please contact your local Endress+Hauser Sales Center.

**EN/DIN flanges, connection dimensions in accordance with EN 1092-1/DIN 2527**

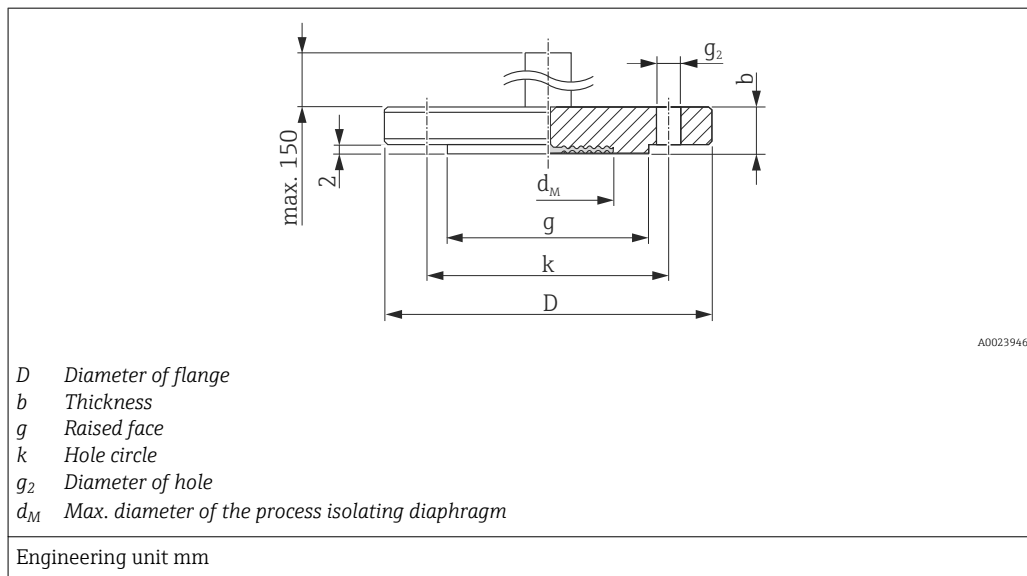

Flange <sup>1) 2) 3)</sup>			Boltholes			Diaphragm seal		Option				
Nominal diameter	Nominal pressure	Shape <sup>4)</sup>	D	b	g	Number	g <sub>2</sub>	k	d <sub>M</sub>	Weight	HP <sup>5)</sup>	LP <sup>6)</sup>
	PN		[mm]	[mm]	[mm]		[mm]	[mm]	[mm]	[mm]		
DN 50	10-40	B1 (D)	165	20	102	4	18	125	59	3.0 (6.62)	A <sup>7) 8)</sup>	TA <sup>7) 8)</sup>
DN 80	10-40	B1 (D)	200	24	138	8	18	160	89	5.2 (11.47)	B <sup>7) 8)</sup>	TB <sup>7) 8)</sup>
DN 100	10-16	B1 (C)	220	20	-	8	18	180	89	4.8 (10.58)	F	TC
DN 100	25-40	B1 (D)	235	24	162	8	22	190	89	6.7 (14.77)	G	TD

- 1) Material: AISI 316L
- 2) The roughness of the surface in contact with the medium, including the raised face of the flanges (all standards) made of Alloy C276, Monel, tantalum, rhodium>gold, gold > 316L or PTFE is R<sub>a</sub> < 0.8 μm (31.5 μin). Lower surface roughness on request.
- 3) The flange raised face is made of the same material as the process isolating diaphragm.
- 4) Description as per DIN 2527 provided in brackets
- 5) Product Configurator, order code for "Process connection, HP/ HP+LP:"
- 6) Product Configurator, order code for "Alternative process connection LP side:"
- 7) Alternatively available with the TempC Membrane.
- 8) Alternatively available with gold-coated TempC Membrane (Product Configurator, order code for "Membrane material" option "G/D").

EN/DIN flanges with barrel (extended diaphragm seal), connection dimensions in accordance with EN 1092-1/DIN 2527

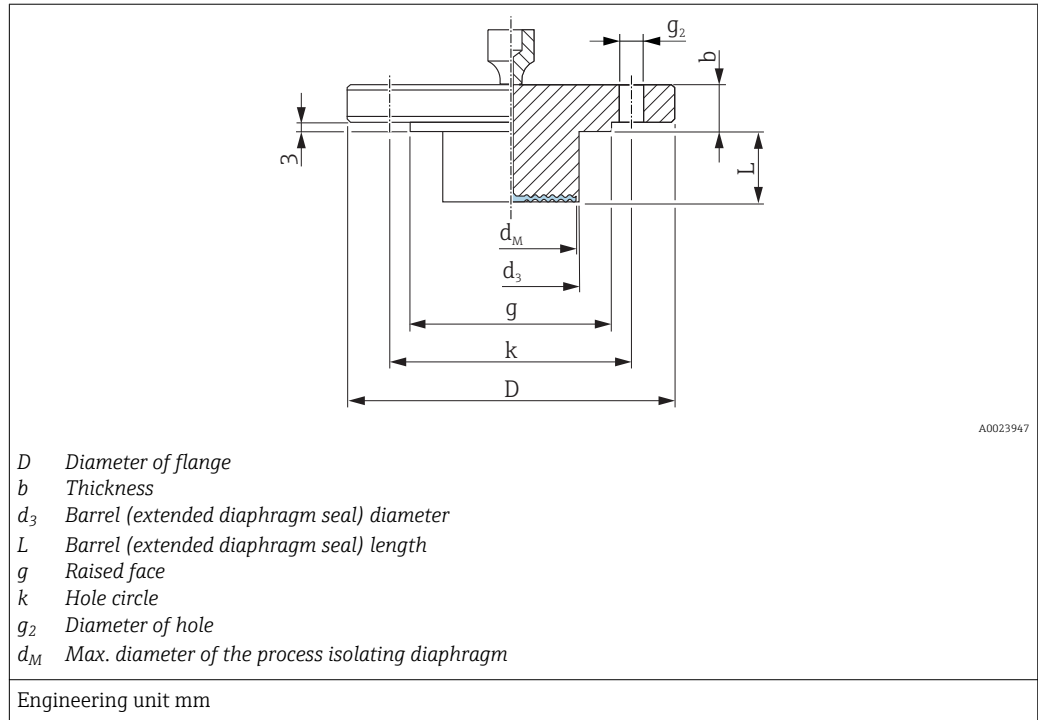

Flange <sup>1) 2)</sup>								Boltholes			Diaphragm seal		Option <sup>3)</sup> (HP + LP)
Nominal diameter	Nominal pressure PN	Shape <sup>4)</sup>	D	b	g	L	d <sub>3</sub>	Number	g <sub>2</sub>	k	d <sub>M</sub>	Weight	
			[mm]	[mm]	[mm]	[mm]	[mm]		[mm]	[mm]	[mm]	[mm]	
DN 80	10-40	B1 (D)	200	24	138	50	76	8	18	160	72	6.2 (13.67)	C
						100						6.7 (14.77)	
						200						7.8 (17.20)	

- 1) Material: AISI 316L
- 2) In the case of process isolating diaphragms made of Alloy C276, Monel oder tantalum, the raised face of the flange and the barrel pipe are made of 316L.
- 3) Product Configurator, order code for "Process connection, HP/ HP+LP:"
- 4) Description as per DIN 2527 provided in brackets

Process connections FMD77 with diaphragm seal

ASME flanges, connection dimensions in accordance with B 16.5, raised face RF

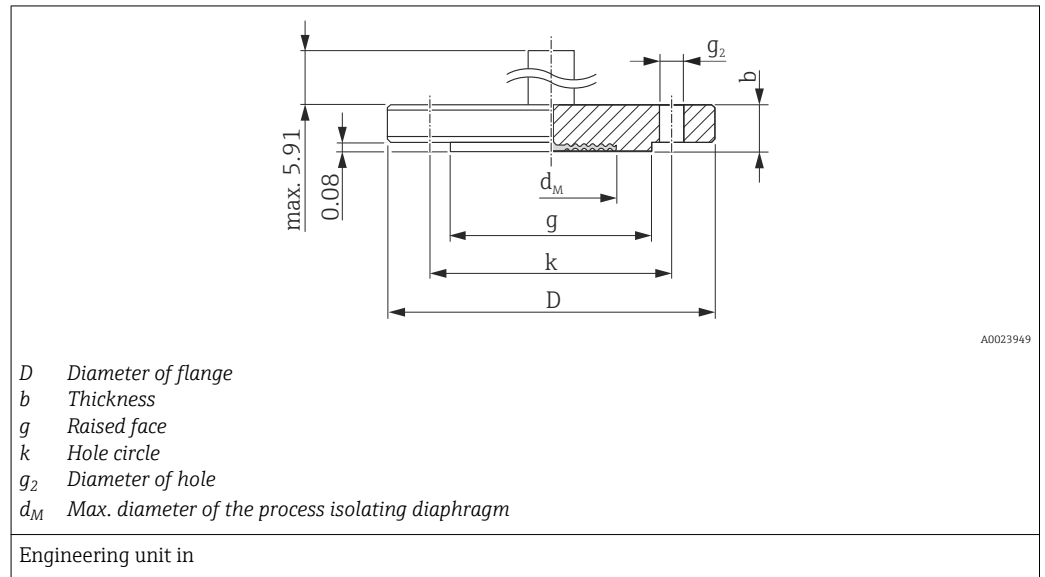

Flange <sup>1) 2) 3)</sup>					Boltholes			Diaphragm seal	Weight	Approval <sup>4)</sup>	Option	
Nominal diameter	Class	D	b	g	Number	<i>g<sub>2</sub></i>	<i>k</i>	<i>d<sub>M</sub></i>			[kg (lb)]	HP <sup>5)</sup>
[in]	[lb./sq.in]	[in]	[in]	[in]		[in]	[in]	[in]				
2	150	6	0.75	3.62	4	0.75	4.75	2.32	2.6 (5.73)	CRN	N <sup>7) 8)</sup>	TE <sup>7) 8)</sup>
2	300	6.5	0.88	3.62	8	0.75	5	2.32	3.4 (7.5)	CRN	O <sup>7) 8)</sup>	TF <sup>7) 8)</sup>
2	400/600	6.5	1	3.62	8	0.75	5	2.32	4.3 (9.48)	-	J	-
3	150	7.5	0.94	5	4	0.75	6	3.5	5.1 (11.25)	CRN	P <sup>7) 8)</sup>	TG <sup>7) 8)</sup>
3	300	8.25	1.12	5	8	0.75	6	3.5	7.0 (15.44)	CRN	R <sup>7) 8)</sup>	TH <sup>7) 8)</sup>
4	150	9	0.94	6.19	8	0.75	7.5	3.5	7.2 (15.88)	CRN	T	TI
4	300	10	1.25	6.19	8	0.88	7.88	3.5	11.7 (25.8)	CRN	W	TJ

- 1) Material: AISI 316/316L. Combination of AISI 316 for required pressure resistance and AISI 316L for required chemical resistance (dual rated)
- 2) The roughness of the surface in contact with the medium, including the raised face of the flanges (all standards) made of Alloy C276, Monel, tantalum, rhodium>gold, gold or PTFE is  $R_a < 0.8 \mu\text{m}$  (31.5  $\mu\text{in}$ ). Lower surface roughness on request.
- 3) The flange raised face is made of the same material as the process isolating diaphragm.
- 4) CSA approval: Product Configurator, order code for "Approval"
- 5) Product Configurator, order code for "Process connection, HP/ HP+LP:"
- 6) Product Configurator, order code for "Alternative process connection LP side:"
- 7) Alternatively available with the TempC Membrane.
- 8) Alternatively available with gold-coated TempC Membrane (Product Configurator, order code for "Membrane material" option "G/D").

**ASME flanges with barrel (extended diaphragm seal), connection dimensions in accordance with ASME B 16.5, raised face RF**

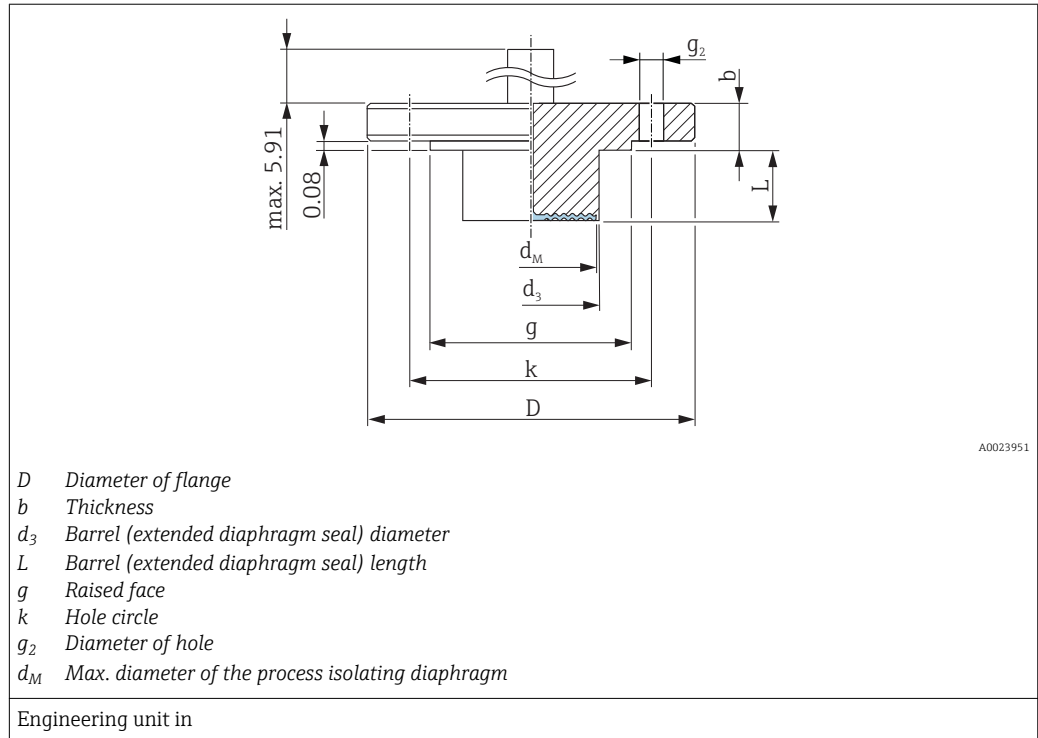

Flange <sup>1) 2)</sup>							Boltholes			Diaphragm seal	Weight	Option <sup>3)</sup> (HP + LP)
Nominal diameter	Class	D	b	g	L	d <sub>3</sub>	Number	g <sub>2</sub>	k	d <sub>M</sub>		
[in]	[lb./sq.in]	[in]	[in]	[in]	[in]	[in]		[in]	[in]		[kg (lb)]	
3	150	7.5	0.94	5	2	2.99	4	0.75	6	2.83	6 (13.23)	Q
					4						6.6 (14.55)	
					6						7.1 (15.66)	
					8						7.7 (16.98)	

1) Material: AISI 316/316L

2) In the case of process isolating diaphragms made of Alloy C276, Monel oder tantalum, the raised face of the flange and the barrel pipe are made of 316L.

3) Product Configurator, order code for "Process connection, HP/ HP+LP:"

**Process connections FMD77 with diaphragm seal**

**JIS flanges, connection dimensions in accordance with JIS B 2220 BL, raised face RF**

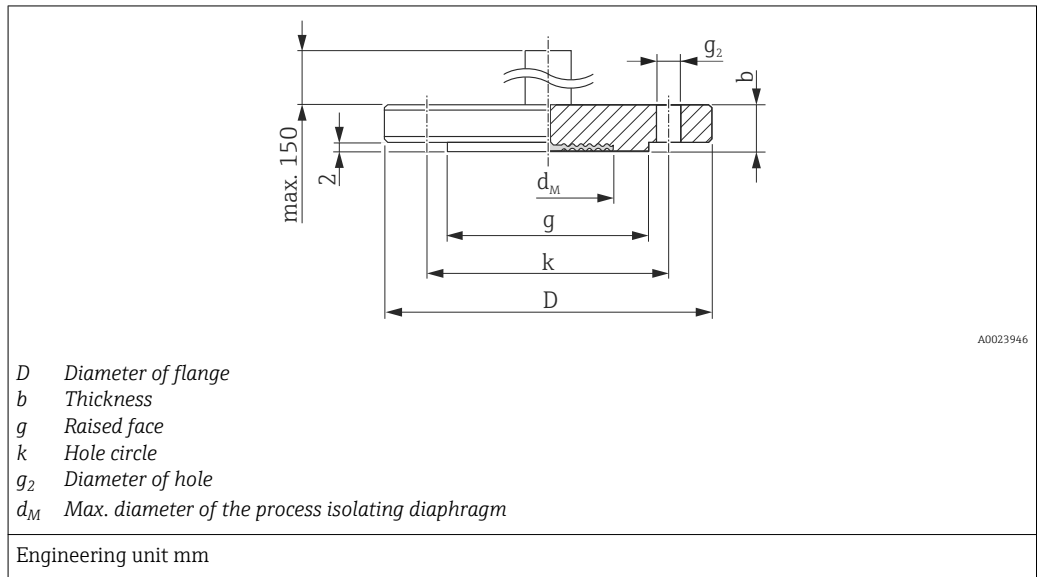

Flange <sup>1) 2) 3)</sup>					Boltholes			Diaphragm seal	Weight	Option	
Nominal diameter	Nominal pressure	D	b	g	Number	g <sub>2</sub>	k	d <sub>M</sub>	[kg (lb)]	HP <sup>4)</sup>	LP <sup>5)</sup>
		[mm]	[mm]	[mm]		[mm]	[mm]	[mm]			
50 A	10 K	155	16	96	4	19	120	59	2.3 (5.07)	X	TK
80 A	10 K	185	18	126	8	19	150	89	3.5 (7.72)	1	TL
100 A	10 K	210	18	151	8	19	175	89	4.7 (10.36)	4	TM

- 1) material: AISI 316
- 2) The roughness of the surface in contact with the medium including the raised face of the flanges (all standards) made of Alloy C276, Monel, tantalum, rhodium-gold or PTFE is  $R_a < 0.8 \mu\text{m}$  ( $31.5 \mu\text{in}$ ). Lower surface roughness on request.
- 3) The flange raised face is made of the same material as the process isolating diaphragm.
- 4) Product Configurator, order code for "Process connection, HP/ HP+LP."
- 5) Product Configurator, order code for "Alternative process connection LP side."

**Process connections FMD77 with diaphragm seal, low-pressure side**

Process connection low-pressure side	Material	Seal	Option <sup>1)</sup>
Mounting: 7/16 – 20 UNF, Process isolating diaphragm low-pressure side AISI 316L			
1/4 – 18 NPT IEC 61518	C22.8	FKM Viton	B
1/4 – 18 NPT IEC 61518,	AISI 316L	FKM Viton	D
1/4 – 18 NPT IEC 61518	Alloy C276	FKM Viton	F
1/4 – 18 NPT IEC 61518	AISI 316L	PTFE+C4-ring	H
1/4 – 18 NPT IEC 61518	Alloy C276	PTFE+C4-ring	J
1/4 – 18 NPT IEC 61518	AISI 316L	EPDM	K
1/4 – 18 NPT IEC 61518	Alloy C276	EPDM	L
1/4 – 18 NPT IEC 61518	AISI 316L	Kalrez	M
1/4 – 18 NPT IEC 61518	Alloy C276	Kalrez	N
1/4 – 18 NPT IEC 61518	AISI 316L	Chemraz	P
1/4 – 18 NPT IEC 61518	Alloy C276	Chemraz	Q
1/4 – 18 NPT IEC 61518	AISI 316L	FKM Viton, cleaned from oil and grease	S
1/4 – 18 NPT IEC 61518	AISI 316L	FKM Viton, cleaned for oxygen service	T

Process connection low-pressure side	Material	Seal	Option <sup>1)</sup>
RC 1/4	AISI 316L	FKM Viton	U
LP diaphragm seal and capillary	AISI 316L	welded	1

1) Product Configurator, order code for "Process connection, LP side; seal."

### FMD78: Selecting the process connection and capillary line

The device can be fitted with different process connections on the high-pressure side (HP) and on the low-pressure side (LP).

The FMD78 can also be fitted with different capillary lengths on the high-pressure side (HP) and on the low-pressure side (LP).

When using diaphragm seal systems with a capillary, sufficient strain relief must be provided to prevent the capillary from bending (capillary bending radius  $\geq 100$  mm (3.94 in)).

#### Example:

- Process connection on high-pressure side = DN80 flange
- Process connection on low-pressure side = DN50 flange
- Capillary length on high-pressure side = 2 m (6.6 ft)
- Capillary length on low-pressure side = 5 m (16 ft)



#### Your benefits:

- Thanks to the variety of order options, the devices can be optimally adapted to the given installation situation
- Reduced costs due to optimum system design
- Easier installation due to adjusted length of capillary on low-pressure side and high-pressure side
- Easier adaptation to existing installation situations

#### Ordering information:

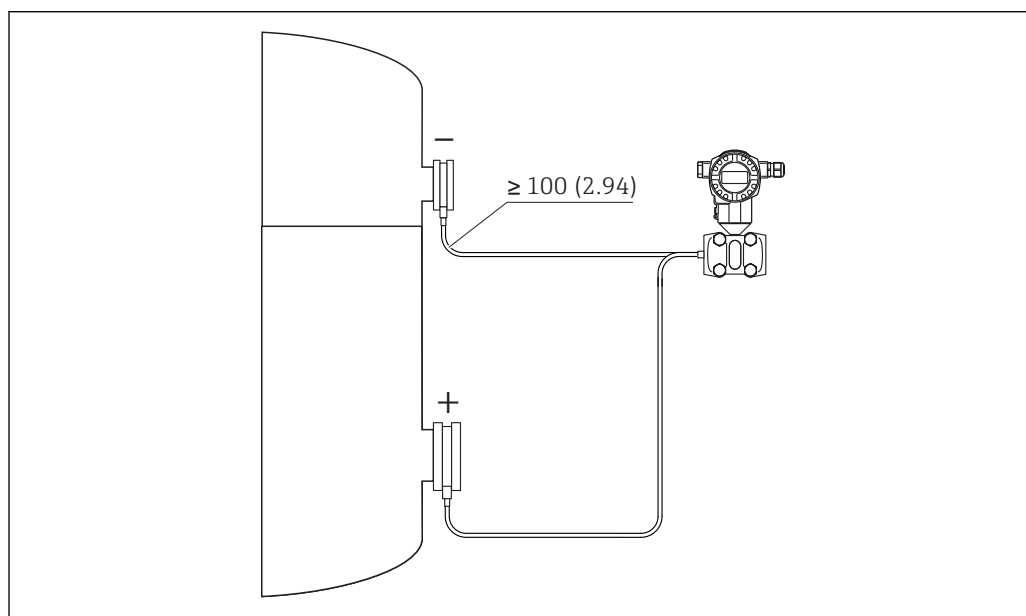
- Process connections are indicated in the relevant section by HP (high-pressure side) and LP (low-pressure side)
- Order details for capillary lengths →  85



 Due to the use of different process connections and capillary lines, it is essential that the device be designed/ordered using the "Applicator Sizing Diaphragm Seal" selection tool, which is available free of charge. Additional information can be found in the "Planning instructions, diaphragm seal systems" section →  94

FMD78 basic device

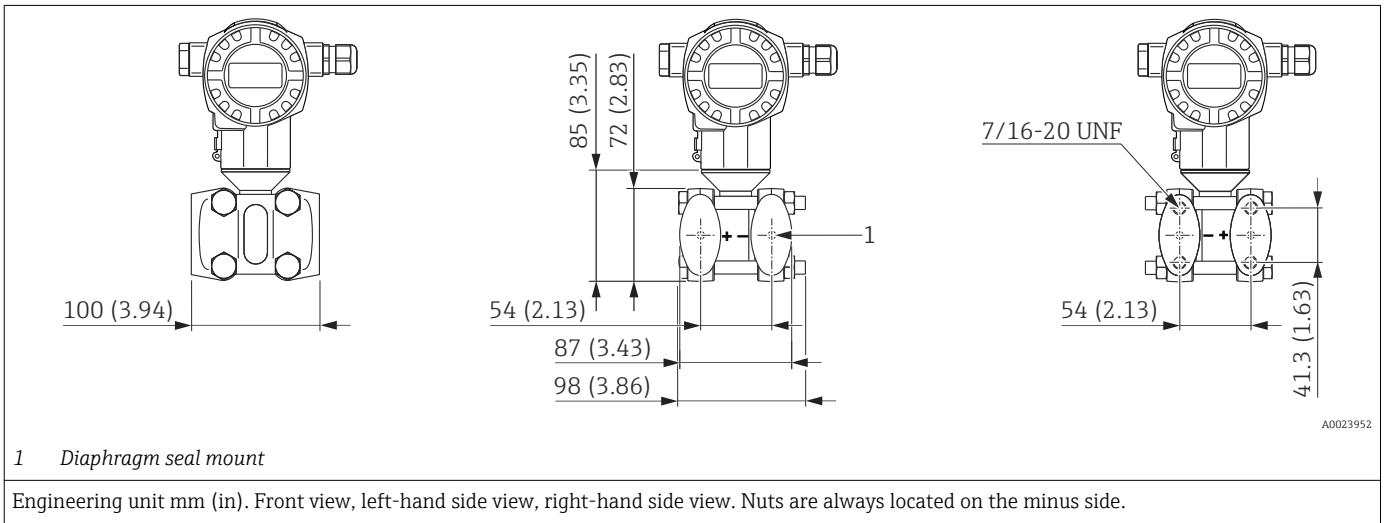

**Process connections FMD78 with diaphragm seal**



- The following drawings are drawings that illustrate how the system works in principle. In other words, the dimensions of a diaphragm seal supplied can deviate from the dimensions given in this document.
- Observe the information in the "Planning instructions for diaphragm seal systems" section → 94
- For further information please contact your local Endress+Hauser Sales Center.

**Diaphragm seal cell structure**

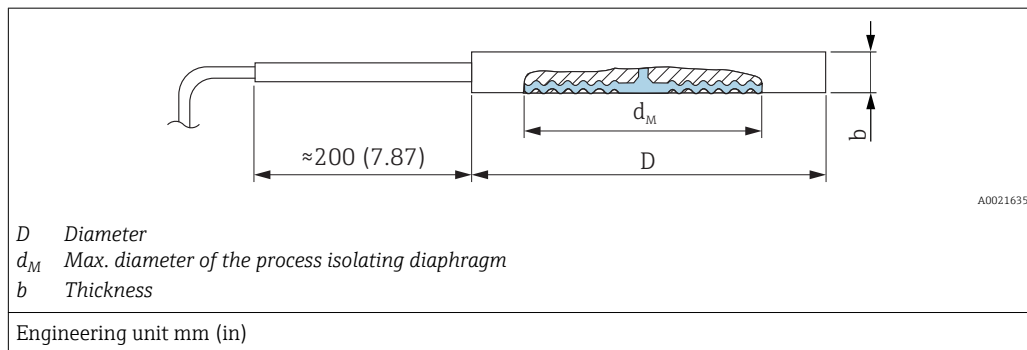

Flange				Diaphragm seal			Approval <sup>1)</sup>	Option	
Material	Nominal diameter	Nominal pressure <sup>2)</sup>	D	b	d <sub>M</sub>	Weight of two diaphragm seals [kg (lb)]		HP <sup>3)</sup>	LP <sup>4)</sup>
			[mm]	[mm]	[mm]				
AISI 316L	DN 50	PN 16-400 <sup>5)</sup>	102	20	59	2.6 (5.73)	-	UF <sup>6)</sup>	UL
	DN 80	PN 16-400 <sup>5)</sup>	138	20	89	4.6 (10.14)	-	UH <sup>6)</sup>	UM
	DN 100	PN 16-400 <sup>5)</sup>	162	20	89	6.2 (13.67)	-	UJ	UN
	[in]	[lb/sq.in]	[in (mm)]	[in (mm)]	[in (mm)]				
	2	150-2500	3.9 (99)	0.79 (20)	2.32 (59)	2.6 (5.73)	CRN	VF <sup>6)</sup>	UP
	3	150-2500	5 (127)	0.79 (20)	3.50 (89)	4.6 (10.14)	CRN	VH <sup>6)</sup>	UR
	4	150-2500	6.22 (158)	0.79 (20)	3.50 (89)	6.2 (13.67)	CRN	VJ	US

- 1) CSA approval: Product Configurator, order code for "Approval"
- 2) The specified nominal pressure applies to the diaphragm seal. The maximum pressure for the measuring device is dependent on the lowest-rated element, with regard to pressure, of the selected components → 45.
- 3) Product Configurator, order code for "Process connection, HP/ HP+LP:"
- 4) Product Configurator, order code for "Alternative process connection LP side:"
- 5) For PTFE coating MWP = 250 bar (3 625 psi), for details, see "Range of application of the PTFE foil" → 41
- 6) With TempC Membrane

**Process connections FMD78 with diaphragm seal**      **Threaded separators**

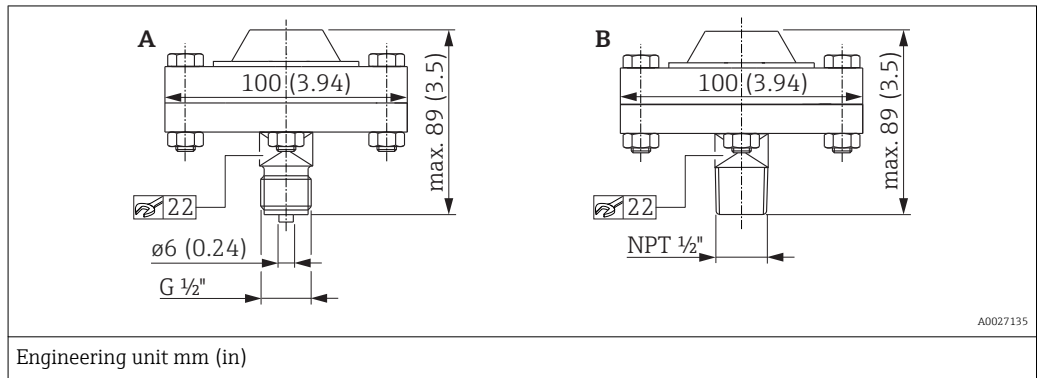

Item	Designation	Material	Measuring range	Nominal pressure	Weight	Option <sup>1)</sup>
			[bar (psi)]		[kg (lb)]	
A	Threaded, ISO 228 G ½ A EN837 with PTFE seal -40 to +260 °C (-40 to +500 °F)	AISI 316L, screws made of A4	≤ 40 (580)	PN 40	1.43 (3.15)	GA <sup>2)</sup>
B	Threaded, ANSI ½ MNPT with PTFE seal -40 to +260 °C (-40 to +500 °F)					RL <sup>2)</sup>

- 1) Product Configurator, order code for "Process connection, HP/ HP+LP:"
- 2) In combination with silicone oil, inert oil and vegetable oil.

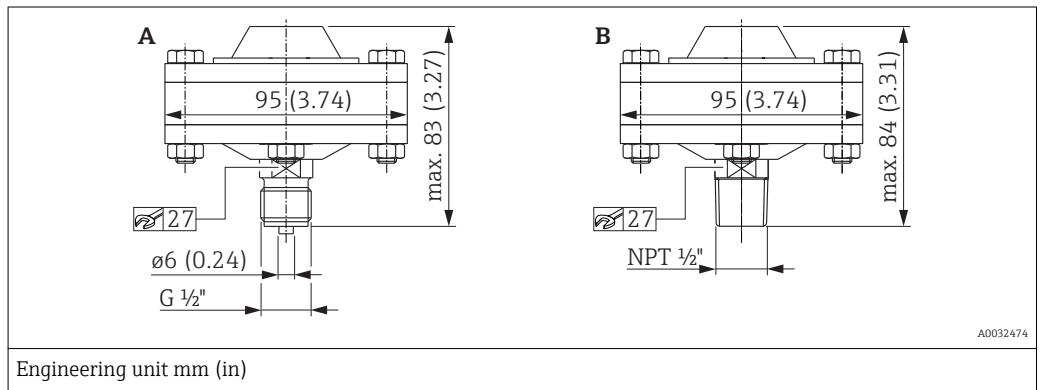

Item	Designation	Material	Measuring range	Nominal pressure	Weight	Option <sup>1)</sup>
			[bar (psi)]		[kg (lb)]	
A	Threaded, ISO 228 G ½ A EN837 with metal seal (silver-plated) -60 to +400 °C (-76 to +752 °F)	AISI 316L, screws made of A4	≤ 40 (580)	PN 40	1.38 kg (3.04 lb)	GA <sup>2)</sup>
B	Threaded, ANSI ½ MNPT with metal seal (silver-plated) -60 to +400 °C (-76 to +752 °F)					RL <sup>2)</sup>

- 1) Product Configurator, order code for "Process connection"
- 2) In combination with high-temperature oil.

## DRD DN50 (65 mm)

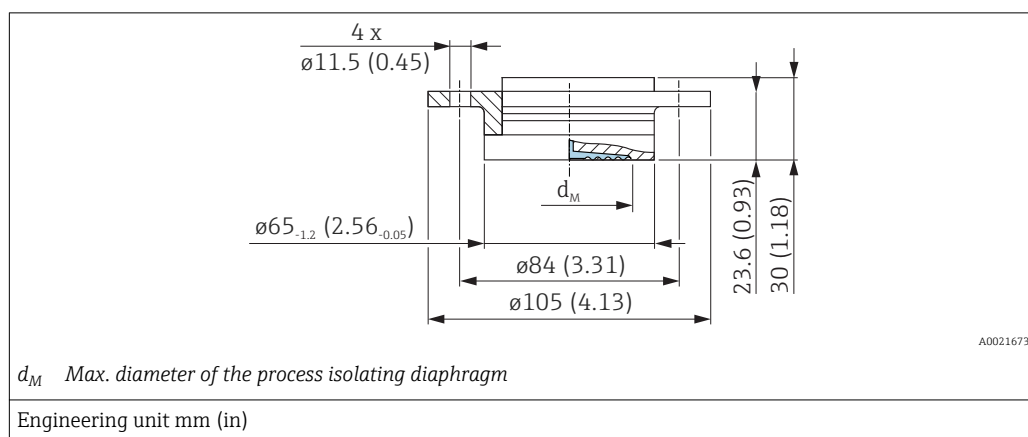

Material <sup>1)</sup>	Nominal pressure	$d_M$		Weight	Option	
		Standard	with TempC Membrane		HP <sup>2)</sup>	LP <sup>3)</sup>
		[mm]	[mm]	[kg (lb)]		
AISI 316L	PN 25	50	48	0.75 (1.65)	TK <sup>4)</sup>	UH <sup>4)</sup>

- 1) Surface roughness of the wetted surfaces  $R_a < 0.76 \mu\text{m}$  (29.9  $\mu\text{in}$ ) as standard.
- 2) Product Configurator, order code for "Process connection, HP/ HP+LP:"
- 3) Product Configurator, order code for "Alternative process connection LP side:"
- 4) Alternatively available with TempC Membrane.

## Tri-Clamp ISO 2852

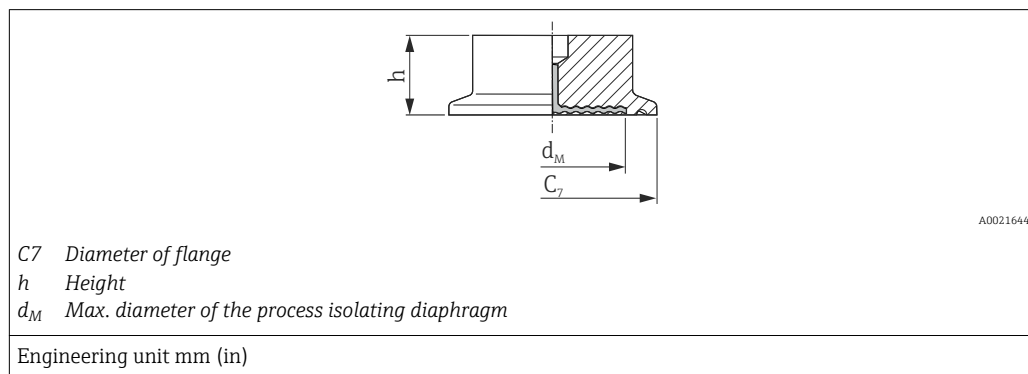

Material <sup>1)</sup>	Nominal diameter ISO 2852	Nominal diameter DIN 32676	Nominal diameter	$C_7$	$d_M$		$h$	Weight	Approval <sup>2)</sup>	Option	
					Standard	with TempC Membrane				HP <sup>3)</sup>	LP <sup>4)</sup>
					[in]	[mm]	[mm]	[mm]	[kg (lb)]		
AISI 316L	ND 25 / 33.7	DN 25	1	50.5	24	-	37	0.32 (0.71)	EHEDG, 3A, CRN	TB	UA
	ND 38	DN 40	1 ½	50.5	36	36	30	1 (2.21)	EHEDG, 3A, CRN	TC <sup>5) 6)</sup>	UB <sup>5) 6)</sup>
	ND 51 / 40	DN 50	2	64	48	41	30	1.1 (2.43)	EHEDG, 3A, CRN	TD <sup>5) 6)</sup>	UC <sup>5) 6)</sup>

Material 1)	Nominal diameter ISO 2852	Nominal diameter DIN 32676	Nominal diameter	C <sub>7</sub>	d <sub>M</sub>		h	Weight	Approval 2)	Option	
					Standard	with TempC Membrane				HP <sup>3)</sup>	LP <sup>4)</sup>
					[in]	[mm]					
	ND 63.5	DN 50	2 ½	77.5	61	61	30	0.7 (1.54)	EHEDG, 3A	TE <sup>7)</sup>	UD <sup>7)</sup>
	ND 76.1	-	3	91	73	61	30	1.2 (2.65)	EHEDG, 3A, CRN	TF <sup>6)</sup>	UE <sup>6)</sup>

- 1) Surface roughness of the wetted surfaces  $R_a < 0.76 \mu\text{m}$  (29.9  $\mu\text{in}$ ) as standard. Lower surface roughness available on request.
- 2) CSA approval: Product Configurator, order code for "Approval"
- 3) Product Configurator, order code for "Process connection, HP/ HP+LP."
- 4) Product Configurator, order code for "Alternative process connection LP side."
- 5) Optionally available as ASME-BPE-compliant diaphragm seal version for use in biochemical processes, surfaces in contact with medium  $R_a < 0.38 \mu\text{m}$  (15  $\mu\text{in}$ ), electropolished; order using the order code for "Additional options 1" or "Additional options 2", option "O".
- 6) Alternatively available with TempC Membrane.
- 7) With TempC Membrane

Process connections FMD78 with diaphragm seal

SMS nozzles with coupling nut

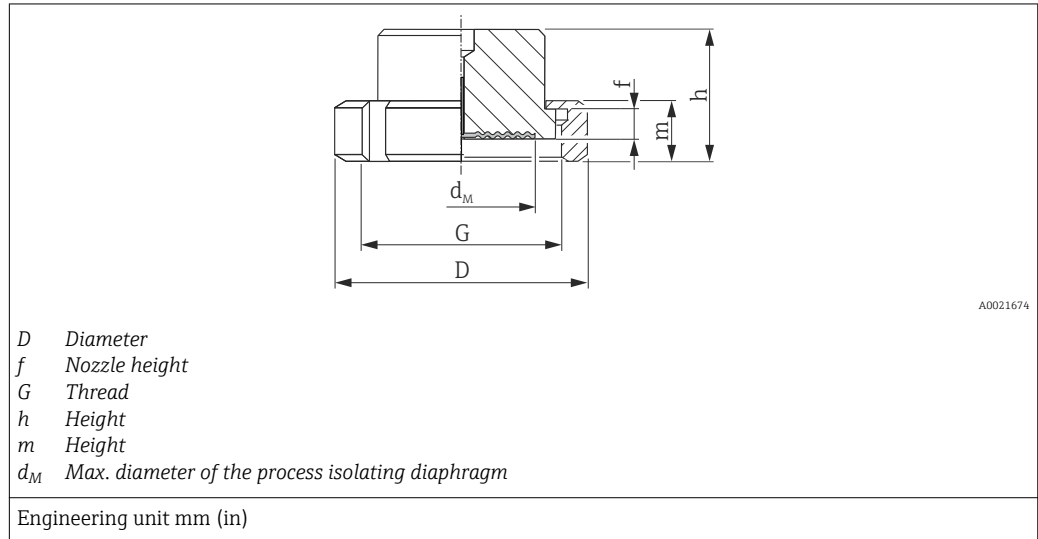

Material <sup>1)</sup>	Nominal diameter	Nominal pressure	D	f	G	m	h	d <sub>M</sub>	Weight [kg (lb)]	Approval	Option	
			[mm]	[mm]		[mm]	[mm]	[mm]			[mm]	HP <sup>2)</sup>
AISI 316L	1 ½	PN 25	74	4	Rd 60 - 1/6	25	57	36	0.65 (1.43)	3A	TH <sup>4)</sup>	UF <sup>4)</sup>
	2	PN 25	84	4	Rd 70 - 1/6	26	62	48	1.05 (2.32)	3A	TI <sup>4)</sup>	UG <sup>4)</sup>

- 1) Surface roughness of the wetted surfaces R<sub>a</sub> < 0.76 μm (29.9 μin) as standard.
- 2) Product Configurator, order code for "Process connection, HP/ HP+LP:"
- 3) Product Configurator, order code for "Alternative process connection LP side:"
- 4) With TempC Membrane

Hygienic connection, sanitary tank spud, barrel (extended diaphragm seal) 2"

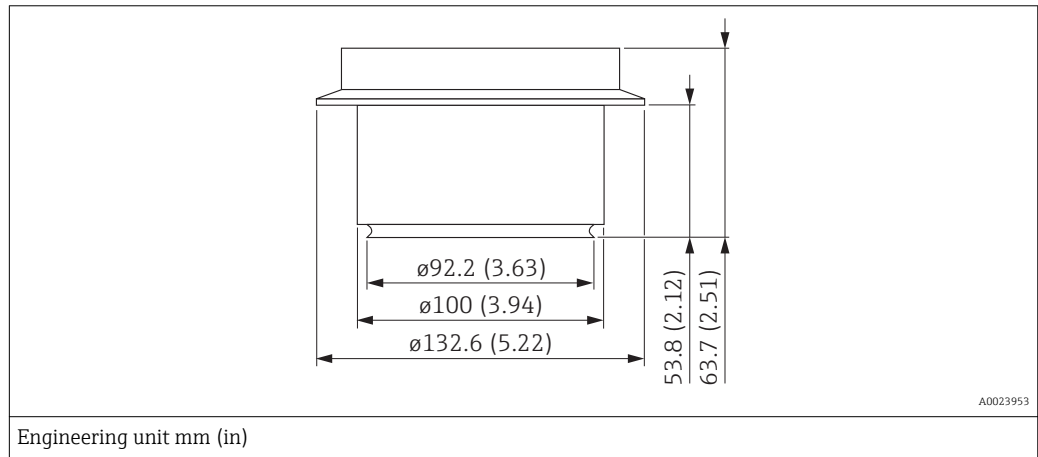

Material <sup>1)</sup>	Weight kg (lbs)	Approval	Option <sup>2)</sup>
AISI 316L	2.5 (5.51)	3A	WH <sup>3) 4)</sup>

- 1) Surface roughness of the wetted surfaces R<sub>a</sub> < 0.76 μm (29.9 μin) as standard. Lower surface roughness on request.
- 2) Product Configurator, order code for "Process connection, HP/ HP+LP:"
- 3) With TempC Membrane
- 4) EPDM seal enclosed

Taper adapter with slotted-nut, DIN 11851

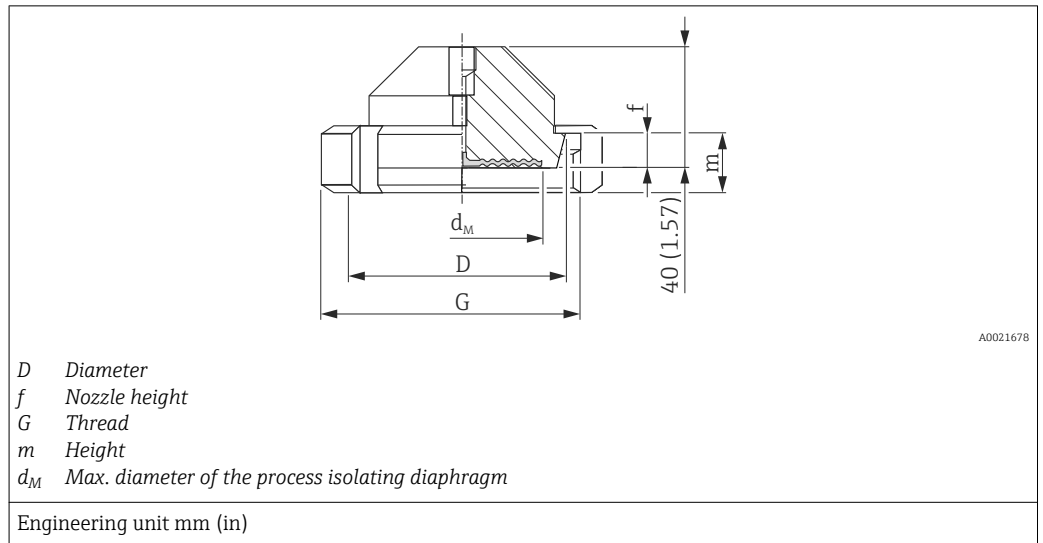

A0021678

Material 1)	Taper adapter				Slotted-nut		Diaphragm seal			Approval	Option	
	Nominal diameter	Nominal pressure	D	f	G	m	d <sub>M</sub>		Weight		HP <sup>2)</sup>	LP <sup>3)</sup>
							Standard	with TempC Membrane				
	[bar]	[mm]	[mm]		[mm]	[mm]	[mm]	[mm]	[kg (lb)]			
AISI 316L	DN 32	PN 40	50	10	Rd 58 x 1/6"	21	32	28	0.45 (0.99)	3A, EHEDG	MI <sup>4)</sup>	TP <sup>4)</sup>
	DN 40	PN 40	56	10	Rd 65 x 1/6"	21	38	36	0.45 (0.99)	3A, EHEDG	MZ <sup>4)</sup>	TU <sup>4)</sup>
	DN 50	PN 25	68.5	11	Rd 78 x 1/6"	19	52	48	1.1 (2.43)	3A, EHEDG	MR <sup>5)</sup>	TR <sup>5)</sup>
	DN 65	PN 25	86	12	Rd 95 x 1/6"	21	66	61	2.0 (4.41)	3A, EHEDG	MS <sup>5)</sup>	TS <sup>5)</sup>
	DN 80	PN 25	100	12	Rd 110 x 1/4"	26	81	61	2.55 (5.62)	3A, EHEDG	MT <sup>5)</sup>	TT <sup>5)</sup>

- 1) Surface roughness of the wetted surfaces  $R_a < 0.76 \mu\text{m}$  (29.9  $\mu\text{in}$ ) as standard.
- 2) Product Configurator, order code for "Process connection, HP/ HP+LP:"
- 3) Product Configurator, order code for "Alternative process connection LP side:"
- 4) with TempC Membrane
- 5) Alternatively available with TempC Membrane.

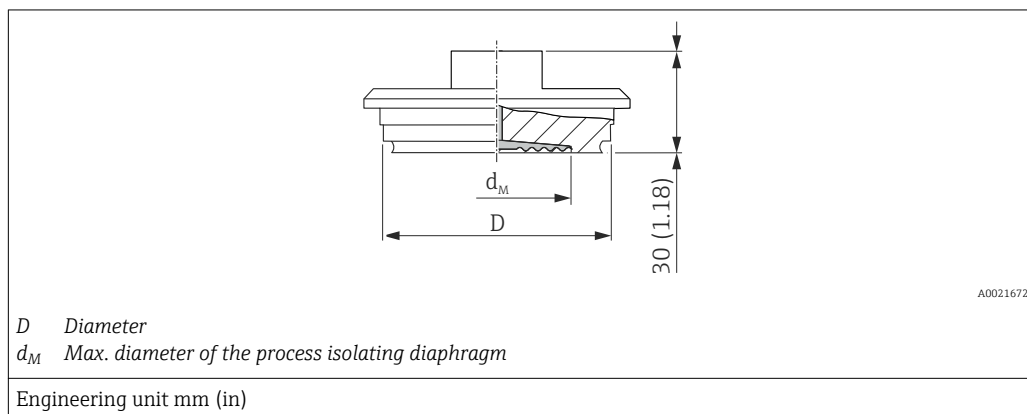
**Process connections FMD78  
with diaphragm seal**
**Varivent for pipes**

Material <sup>1)</sup>	Designation	Nominal pressure	D	$d_M$		Weight	Approval	Option	
				Standard	with TempC membrane			HP <sup>2)</sup>	LP <sup>3)</sup>
				[mm]	[mm]				
AISI 316L	Type F for pipes DN 25 - DN 32	PN 40	50	34	36	0.4 (0.88)	EHEDG, 3A	TU <sup>4)</sup>	UK <sup>4)</sup>
AISI 316L	Type N for pipes DN 40 - DN 162	PN 40	68	58	61	0.8 (1.76)	EHEDG, 3A	TR <sup>5)</sup>	-

- 1) Surface roughness of the wetted surfaces  $R_a < 0.76 \mu\text{m}$  (29.9  $\mu\text{in}$ ) as standard.
- 2) Product Configurator, order code for "Process connection, HP/ HP+LP:"
- 3) Product Configurator, order code for "Alternative process connection LP side:"
- 4) With TempC membrane
- 5) Alternatively available with TempC membrane.

**Process connections FMD78 with diaphragm seal**      **NEUMO BioControl**

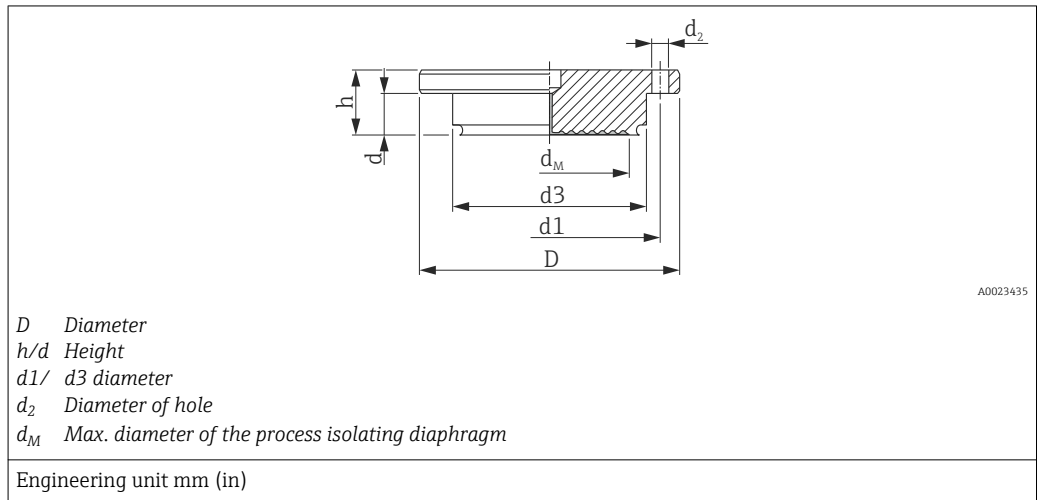

Material <sup>1)</sup>	NEUMO BioControl (Process temperature range: -10 to +200 °C (+14 to +392 °F))							Diaphragm seal			Approval	Option	
	Nominal diameter	Nominal pressure [bar]	D [mm]	d <sub>2</sub> [mm]	d <sub>3</sub> [mm]	d <sub>1</sub> [mm]	h [mm]	d <sub>M</sub>		Weight [kg (lb)]		HP <sup>2)</sup>	LP <sup>3)</sup>
								Standard [mm]	with TempC membrane [mm]				
AISI 316L	DN 50	PN 16	90	4 x Ø 9	50	70	27	40	36	1.1 (2.43)	3A	S4 <sup>4)</sup>	TV
	DN 80	PN 16	140	4 x Ø 11	87.4	115	37	61	61	2.6 (5.73)	3A	S6 <sup>4)</sup>	TW

- 1) Surface roughness of the wetted surfaces  $R_a < 0.76 \mu\text{m}$  (29.9  $\mu\text{in}$ ) as standard.
- 2) Product Configurator, order code for "Process connection, HP/ HP+LP:"
- 3) Product Configurator, order code for "Alternative process connection LP side:"
- 4) With TempC membrane

**Universal process adapter**

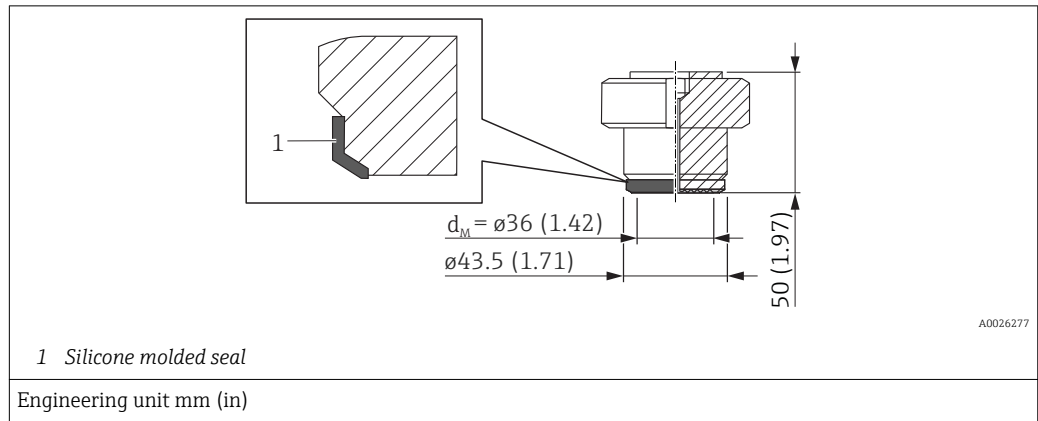

Designation	Nominal pressure	Material <sup>1)</sup>	Weight	Approval	Option	
			[kg (lb)]		HP <sup>2)</sup>	LP <sup>3)</sup>
Universal adapter with silicone molded seal (spare part no.: 52023572) FDA 21CFR177.2600/USP Class VI	PN 10	AISI 316L (1.4435)	0.8 (1.76)	3A, EHEDG	00 <sup>4) 5)</sup>	UT <sup>4) 5)</sup>

- 1) Surface roughness of the wetted surfaces  $R_a < 0.76 \mu\text{m}$  (29.9  $\mu\text{in}$ ) as standard.
- 2) Product Configurator, order code for "Process connection, HP/ HP+LP:"
- 3) Product Configurator, order code for "Alternative process connection LP side:"
- 4) Endress+Hauser supplies these slotted nuts in stainless steel AISI 304 (DIN/EN material number 1.4301) or in AISI 304L (DIN/EN material number 1.4307).
- 5) With TempC membrane.

Process connections FMD78 with diaphragm seal

EN/DIN flanges, connection dimensions in accordance with EN 1092-1/DIN 2527, JIS flanges, connection dimensions in accordance with JIS B 2220 BL

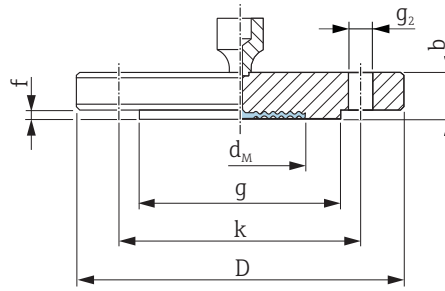

A0021680

- D Diameter of flange
- b Thickness
- g Raised face
- f Thickness of raised face
- k Hole circle
- g<sub>2</sub> Diameter of hole

Engineering unit mm

Flange <sup>1) 2) 3)</sup>							Boltholes			Diaphragm seal		Option	
Nominal diameter	Nominal pressure	Shape <sup>4)</sup>	D	b	g	f	Number	g <sub>2</sub>	k	d <sub>M</sub> [mm]	Weight	HP <sup>5)</sup>	LP <sup>6)</sup>
			[mm]	[mm]	[mm]	[mm]		[mm]	[mm]	[mm]	[kg (lb)]		
DN 50	PN 10-40	B1 (D)	165	20	102	3	4	18	125	59	3.0 (6.62)	B3 <sup>7) 8)</sup>	TA <sup>7) 8)</sup>
DN 80	PN 10-40	B1 (D)	200	24	138	3.5	8	18	160	89	5.3 (11.69)	B5 <sup>7) 8)</sup>	TB <sup>7) 8)</sup>
DN 100	PN 10-16	B1 (C)	220	20	158	4	8	18	180	89	4.5 (9.92)	BT	TC
DN 100	PN 25-40	B1 (D)	235	24	162	5	8	22	190	89	7 (15.44)	B6	TD

- 1) material: AISI 316L
- 2) The roughness of the surface in contact with the medium, including the raised face of the flanges (all standards) made of Alloy C276, Monel, tantalum, rhodium>gold, gold or PTFE is R<sub>a</sub> < 0.8 μm (31.5 μin). Lower surface roughness on request.
- 3) The flange raised face is made of the same material as the process isolating diaphragm.
- 4) Description as per DIN 2527 provided in brackets
- 5) Product Configurator, order code for "Process connection, HP/ HP+LP:"
- 6) Product Configurator, order code for "Alternative process connection LP side:"
- 7) Alternatively available with TempC Membrane.
- 8) Alternatively available with gold-coated TempC Membrane (Product Configurator, order code for "Membrane material" option "G").

Flange <sup>1) 2) 3)</sup>						Boltholes			Diaphragm seal		Option	
Nominal diameter	Nominal pressure	D	b	g	f	Number	g <sub>2</sub>	k	d <sub>M</sub> [mm]	Weight	HP <sup>4)</sup>	LP <sup>5)</sup>
		[mm]	[mm]	[mm]	[mm]		[mm]	[mm]	[mm]	[kg (lb)]		
50 A	10 K	155	16	96	2	4	19	120	59	2.3 (5.07)	CF	TK
80 A	10 K	185	18	127	2	8	19	150	89	3.3 (7.28)	KL	TL
100 A	10 K	210	18	151	2	8	19	175	89	4.4 (9.7)	KH	TM

- 1) material: AISI 316L
- 2) The roughness of the surface in contact with the medium including the raised face of the flanges (all standards) made of Alloy C276, Monel, tantalum, rhodium>gold or PTFE is R<sub>a</sub> < 0.8 μm (31.5 μin). Lower surface roughness on request.
- 3) The flange raised face is made of the same material as the process isolating diaphragm.
- 4) Product Configurator, order code for "Process connection, HP/ HP+LP:"
- 5) Product Configurator, order code for "Alternative process connection LP side:"

Process connections FMD78 with diaphragm seal

EN/DIN flanges with barrel (extended diaphragm seal), connection dimensions in accordance with EN 1092-1/DIN 2527 and DIN 2501-1

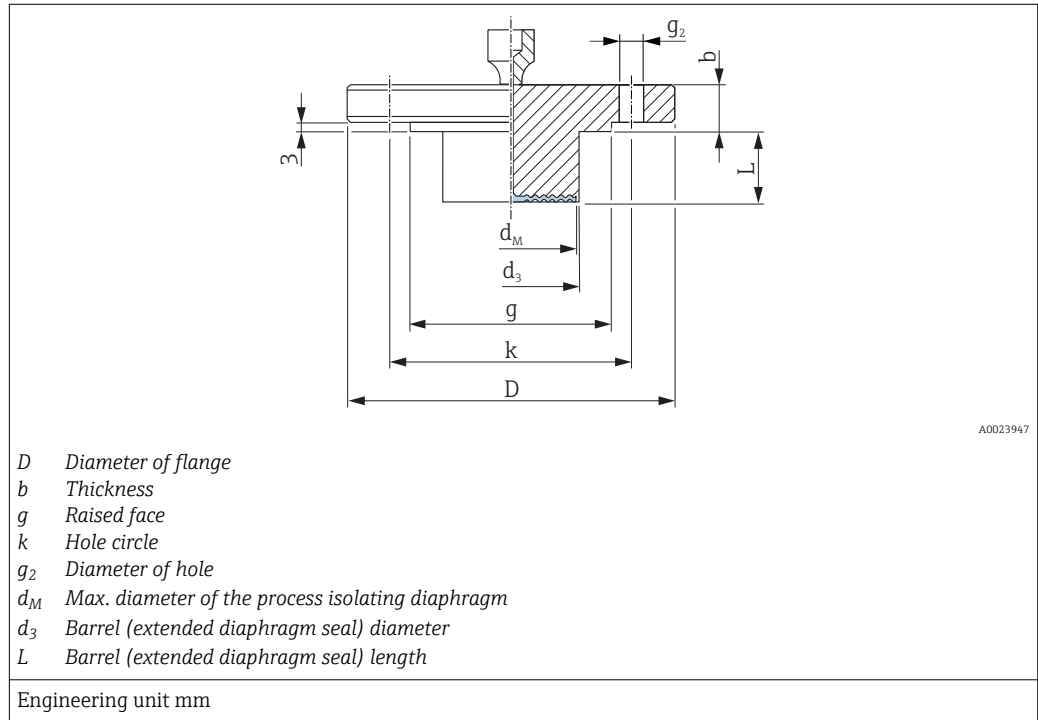

Flange <sup>1) 2)</sup>							Boltholes				Diaphragm seal		Option <sup>3)</sup> (HP + LP)
Nominal diameter	Nominal pressure	Shape <sup>4)</sup>	D	b	g	L	d <sub>3</sub>	Number	g <sub>2</sub>	k	d <sub>M</sub> [mm]	Weight	
			[mm]	[mm]	[mm]	[mm]			[mm]	[mm]	[mm]	[mm]	
DN 80	PN 10-40	B1 (D)	200	24	138	50	76	8	18	160	72	6.2 (13.67)	D4
						100						6.7 (14.77)	
						200						7.8 (17.20)	

- 1) material: AISI 316L
- 2) In the case of process isolating diaphragms made of Alloy C276, Monel oder tantalum, the raised face of the flange and the barrel pipe are made of 316L.
- 3) Product Configurator, order code for "Process connection, HP/ HP+LP:"
- 4) Description as per DIN 2527 provided in brackets

Process connections FMD78 with diaphragm seal

ASME flanges, in accordance with connection dimensions ASME B 16.5, raised face RF

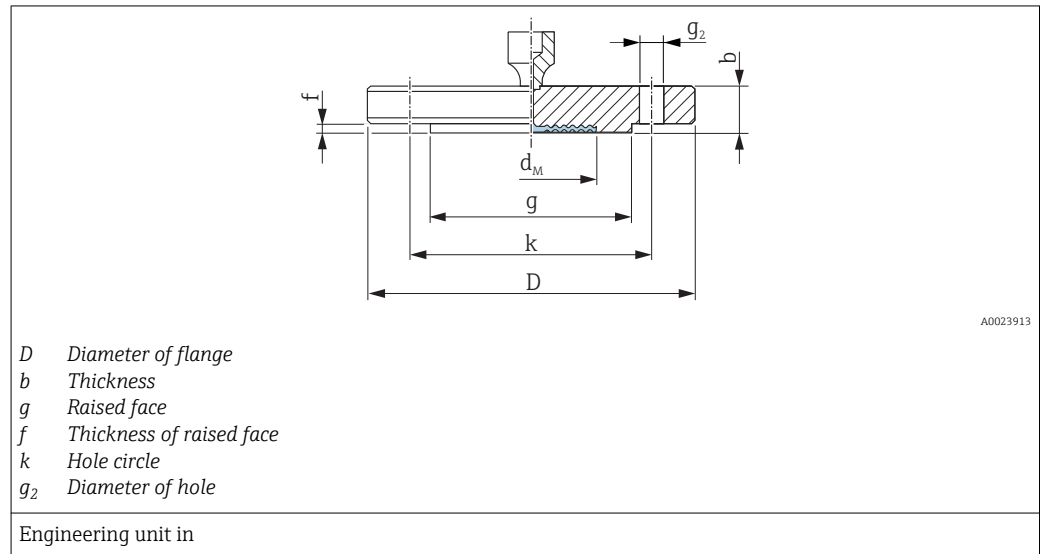

Flange <sup>1) 2) 3)</sup>						Boltholes			Diaphragm seal		Approval <sup>4)</sup>	Option	
Nominal diameter	Class	D	b	g	f	Number	g <sub>2</sub>	k	d <sub>M</sub>	Weight		HP <sup>5)</sup>	LP <sup>6)</sup>
[in]	[lb./sq.in]	[in]	[in]	[in]	[in]		[in]	[in]	[in]	[kg (lb)]			
2	150	6	0.75	3.62	0.06	4	0.75	4.75	2.32	2.2 (4.85)	CRN		
2	300	6.5	0.88	3.62	0.06	8	0.75	5	2.32	3.4 (7.5)	CRN	AR <sup>7) 8)</sup>	TF <sup>7) 8)</sup>
2	400/600	6.5	1	3.62	0.25	8	0.75	5	2.32	4.3 (9.48)	-	AJ	-
3	150	7.5	0.94	5	0.06	4	0.75	6	3.5	5.1 (11.25)	CRN	AG <sup>7) 8)</sup>	TG <sup>7) 8)</sup>
3	300	8.25	1.12	5	0.06	8	0.88	6	3.5	7.0 (15.44)	CRN	AS <sup>7) 8)</sup>	TH <sup>7) 8)</sup>
4	150	9	0.94	6.19	0.06	8	0.75	7.5	3.5	7.2 (15.88)	CRN	AH	TI
4	300	10	1.25	6.19	0.06	8	0.88	7.88	3.5	11.7 (25.8)	CRN	AT	TJ

- 1) Material AISI 316/316L: Combination of AISI 316 for required pressure resistance and AISI 316L for required chemical resistance (dual rated)
- 2) The roughness of the surface in contact with the medium, including the raised face of the flanges (all standards) made of Alloy C276, Monel, tantalum, rhodium>gold, gold or PTFE is R<sub>a</sub> < 0.8 μm (31.5 μin). Lower surface roughness on request.
- 3) The flange raised face is made of the same material as the process isolating diaphragm.
- 4) CSA approval: Product Configurator, order code for "Approval"
- 5) Product Configurator, order code for "Process connection, HP/ HP+LP:"
- 6) Product Configurator, order code for "Alternative process connection LP side:"
- 7) Alternatively available with the TempC Membrane.
- 8) Alternatively available with gold-coated TempC Membrane (Product Configurator, order code for "Membrane material" option "G").

**ASME flanges with barrel (extended diaphragm seal), connection dimensions in accordance with ASME B 16.5, raised face RF**

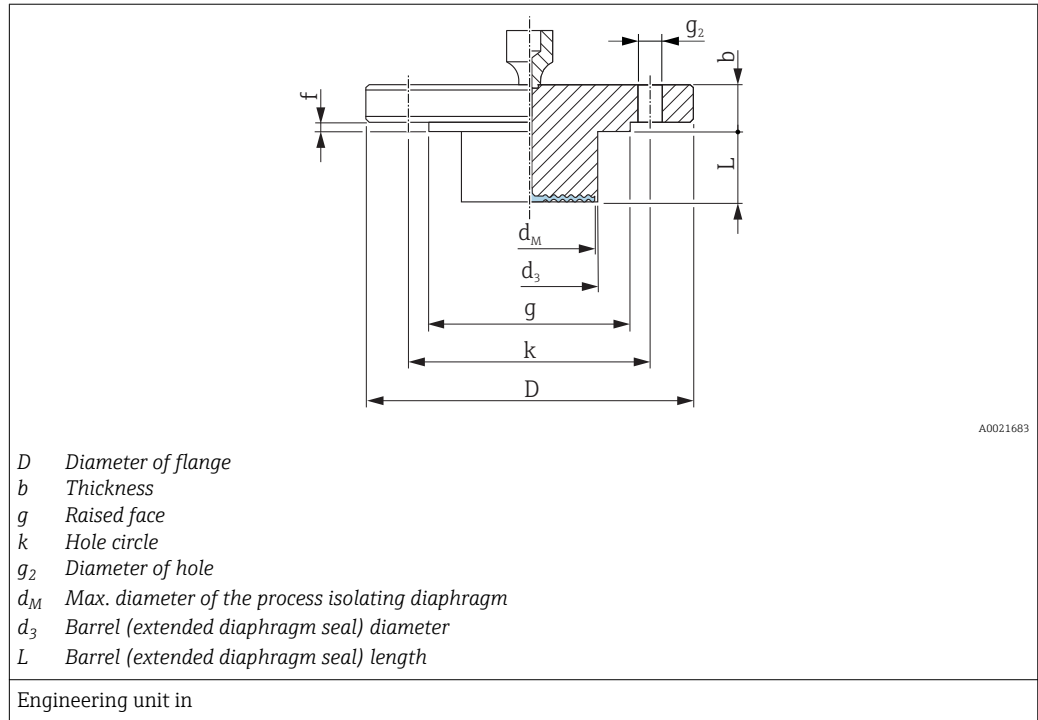

Flange <sup>1) 2)</sup>						Boltholes			Diaphragm seal		Approval <sup>3)</sup>	Option <sup>4)</sup> (HP + LP)
Nominal diameter	Class	D	b	g	f	Number	g <sub>2</sub>	k	d <sub>M</sub>	Weight		
[in]	[lb./sq.in]	[in]	[in]	[in]	[in]		[in]	[in]	[in]	[kg (lb)]		
3	150	7.5	0.94	5	0.06	4	0.75	6	2.83	<sup>5)</sup>	CRN	J4 <sup>5)</sup>
4	150	9	0.94	6.19	0.06	8	0.75	7.5	3.5	<sup>5)</sup>	CRN	J5 <sup>5)</sup>

- 1) Material: AISI 316/316L. Combination of AISI 316 for required pressure resistance and AISI 316L for required chemical resistance (dual rated)
- 2) In the case of process isolating diaphragms made of Alloy C276, Monel or tantalum, the raised face of the flange and the barrel pipe are made of 316L.
- 3) CSA approval: Product Configurator, order code for "Approval"
- 4) Product Configurator, order code for "Process connection, HP/ HP+LP:"
- 5) Choice of 2", 4", 6" or 8" barrel (extended diaphragm seal), for diameter and weight of barrel (extended diaphragm seal) see the following table

Option <sup>1)</sup>	Nominal diameter	Class	(L)	d <sub>3</sub>	Weight
	[in]	[lb./sq.in]	in (mm)	in (mm)	[kg (lb)]
J4	3	150	2 (50.8) / 4 (101.6) / 6 (152.4) / 8 (203.2)	2.99 (76)	6.0 (13.2) / 6.6 (14.5) / 7.1 (15.7) / 7.8 (17.2)
J5	4	150	2 (50.8) / 4 (101.6) / 6 (152.4) / 8 (203.2)	3.7 (94)	8.6 (19) / 9.9 (21.8) / 11.2 (24.7) / 12.4 (27.3)

- 1) Product Configurator, order code for "Process connection"

Separate housing: Wall and pipe mounting with mounting bracket

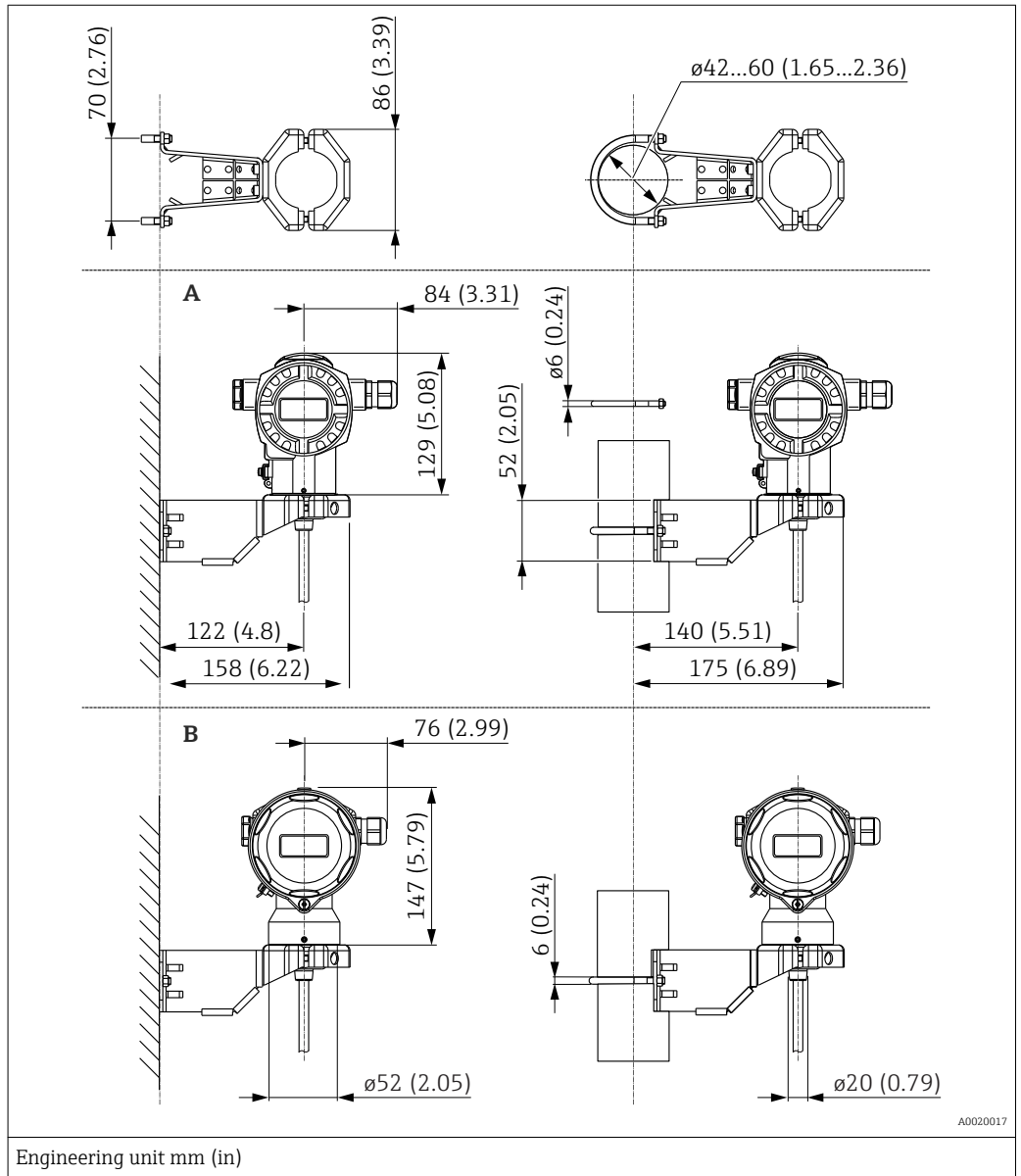

Item	Designation	Weight in kg (lb)		Option <sup>1)</sup>
		Housing (T14 or T17)	Mounting bracket	
A	Dimensions with T14 housing, optional side display	→ 47	0.5 (1.10)	U
B	Dimensions with T17 housing, optional side display			

1) Product Configurator, order code for "Additional options 2", version "G"

Also available for order as a separate accessory: part number 71102216

## Flushing rings

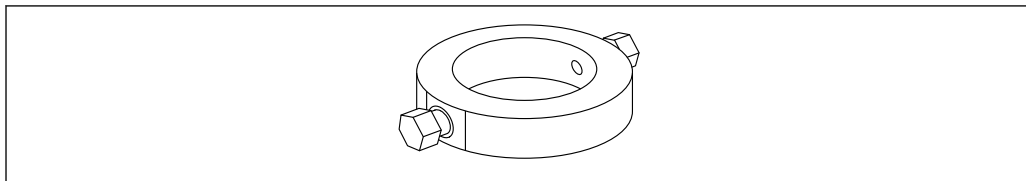

A0028007

Use flushing rings if there is a risk of medium buildup or clogging at the process connection. The flushing ring is fitted between the process connection and the process connection provided by the customer.

Using the two lateral flushing holes, medium buildup or clogging in front of the process isolating diaphragm can be rinsed away and the pressure chamber vented.

Various nominal widths and forms allow adaption to the respective process flange.

For other details (dimension, weight, materials), see SD01553P/00/EN "Mechanical accessories for pressure measuring devices".

**Order options**

Flushing rings can be ordered as a separate accessory or as an order option for the device.

Material	Nominal diameter	Approval <sup>1)</sup>	Accessory <sup>2)</sup> Part number	Order option <sup>3) 4)</sup>	
				FMD77	FMD78 <sup>5)</sup>
AISI 316L	EN1092-1				
	DN25	-	71377379	-	-
	DN50	-	71377380	PP	PP
	DN80	-	71377383	PQ	PQ
	ASME B16.5				
	NPS 1"	-	71377369	-	-
	NPS 2"	CRN	71377370	PL	PL
	NPS 3"	CRN	71377371	PM	PM

1) CSA approval: Product Configurator, order code for "Approval"

2) Inspection certification according to EN10204-3.1 material

3) Product Configurator order code for "Accessories enclosed"

4) Certificates ordered with the equipment (3.1 material certificate and NACE declaration of conformity and PMI tests) apply to the transmitters and flushing rings listed in the table.

5) Scope of delivery: 2 x

Endress+Hauser offers additional flushing rings as **Technical Special Products (TSP)**.

Weight	Component part	Weight
	Housing	See "Housing" section
	Process connection	See "Process connections" section
	Capillary with armoring made of AISI 316L (1.4404)	0.16 kg/m (0.35 lb/m) + 0.2 kg (0.44 lb) (weight per capillary line)
	Capillary with armoring made of AISI 316L (PVC)	0.21 kg/m (0.46 lb/m) + 0.2 kg (0.44 lb) (weight per capillary line)
	Capillary with armoring made of AISI 316L (PTFE)	0.29 kg/m (0.64 lb/m) + 0.2 kg (0.44 lb) (weight per capillary line)

**Materials not in contact with process Transmitter housing**

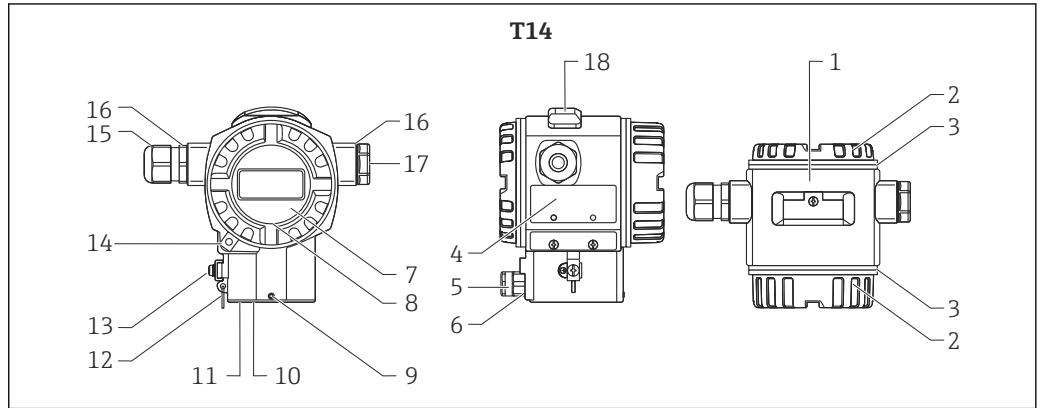

A0020019

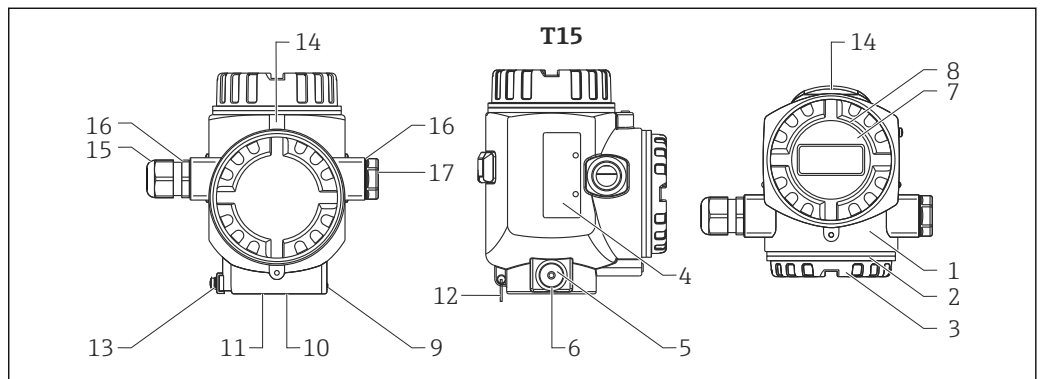

A0020020

Item number	Component part	Material
1	T14 and T15 housing, RAL 5012 (blue)	<ul style="list-style-type: none"> <li>Die-cast aluminum with protective powder-coating on polyester base</li> <li>Thread coating: Heat-curing lubricant varnish</li> </ul>
1	T14 housing	<ul style="list-style-type: none"> <li>Precision casting AISI 316L (1.4435)</li> <li>Thread coating: Heat-curing lubricant varnish</li> </ul>
2	Cover, RAL 7035 (gray)	Die-cast aluminum with protective powder-coating on polyester base Precision cast AISI 316L (1.4435) (cover made of 316L if T14 housing made of 316L)
4	Nameplates	<ul style="list-style-type: none"> <li>AISI 316L (1.4404), if T14 housing is precision-cast</li> <li>Anodized aluminum, if housing T14/T15 of die-cast aluminum</li> </ul>
5	Pressure compensation filter	AISI 316L (1.4404) and PBT-FR
6	Pressure compensation filter, O-ring	VMQ or EPDM
7	Sight glass	Mineral glass
8	Sight glass seal	Silicone (VMQ)
9	Screw	A4
10	Sealing ring	EPDM
11	Snap ring	PA66-GF25
12	Snap ring for nameplates	AISI 304 (1.4301)/AISI 316 (1.4401)
13	External ground terminal	AISI 316L (1.4404)
14	Cover clamp	Clamp AISI 316L (1.4435), screw A4

Item number	Component part	Material
15	Cable entry	Polyamide (PA) or CuZn nickel-plated
16	Seal of cable entry and plug	Silicone (VMQ)
17	Blind plug	PBT-GF30 FR, for dust ignition-proof and Exd: AISI 316L (1.4435)
18	External operation (keys and key cover), RAL 7035 (gray)	Polycarbonate PC-FR, screw A4

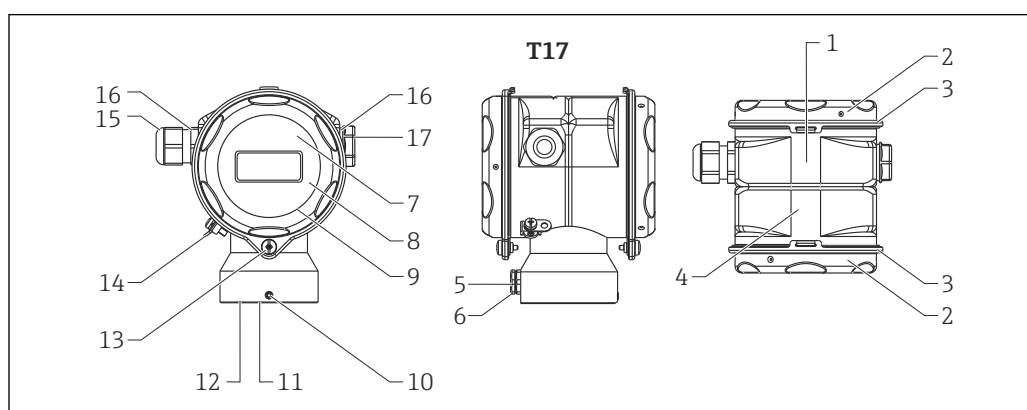

A0020021

Item number	Component part	Material
1	T17 housing	AISI 316L (1.4404)
2	Cover	AISI 316L (1.4404)
3	Cover seal	EPDM
4	Nameplates	Lasered on
5	Pressure compensation filter	AISI 316L (1.4404) and PBT-FR
6	Pressure compensation filter, O-ring	VMQ or EPDM
7	Sight glass for non-hazardous area, ATEX Ex ia, NEPSI Zone 0/1 Ex ia, IECEx Zone 0/1 Ex ia, FM NI, FM IS, CSA IS	Polycarbonate (PC)
8	Sight glass for ATEX 1/2 D, ATEX 1/3 D, ATEX 1 GD, ATEX 1/2 GD, ATEX 3 G, FM DIP, CSA dust ignition-proof	Mineral glass
9	Sight glass seal	EPDM
10	Screw	A2-70
11	Sealing ring	EPDM
12	Snap ring	PA6
13	Screw	A4-50 Thread coating: Heat-curing lubricant varnish
14	External ground terminal	AISI 316L (1.4404)
15	Cable entry	Polyamide (PA), for dust ignition-proof: CuZn nickel-plated
16	Seal of cable entry and plug	Silicone (VMQ)
17	Blind plug	PBT-GF30 FR, for dust ignition-proof: AISI 316L (1.4435)

Connecting parts

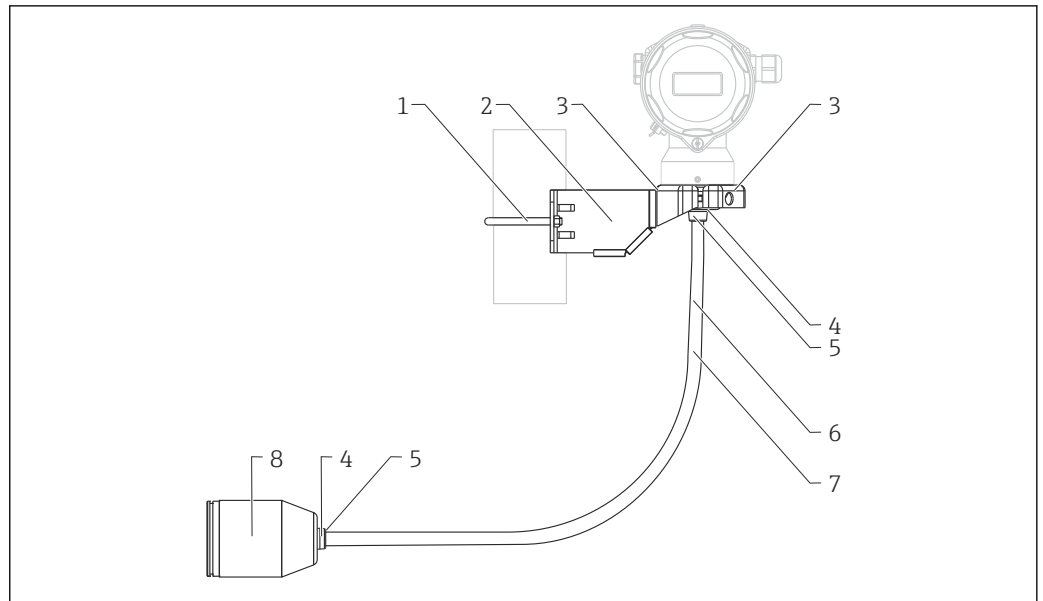

A0026172

Item number	Component part	Material
1	Mounting bracket	Bracket AISI 316L (1.4404)
2		Screw and nuts A4-70
3		Half-shells: AISI 316L (1.4404)
4	Seal for cable from separate housing	EPDM
5	Gland for cable from separate housing	AISI 316L (1.4404)
6	PE cable for separate housing	Abrasion-proof cable with strain-relief Dynema members; shielded using aluminum-coated foil; insulated with polyethylene (PE-LD), black; copper wires, twisted, UV-resistant
7	FEP cable for separate housing	Abrasion-proof cable; shielded using galvanized steel wire netting; insulated with fluorinated ethylene propylene (FEP), black; copper cores, twisted, UV-resistant
8	Process connection adapter for separate housing	AISI 316L (1.4404)

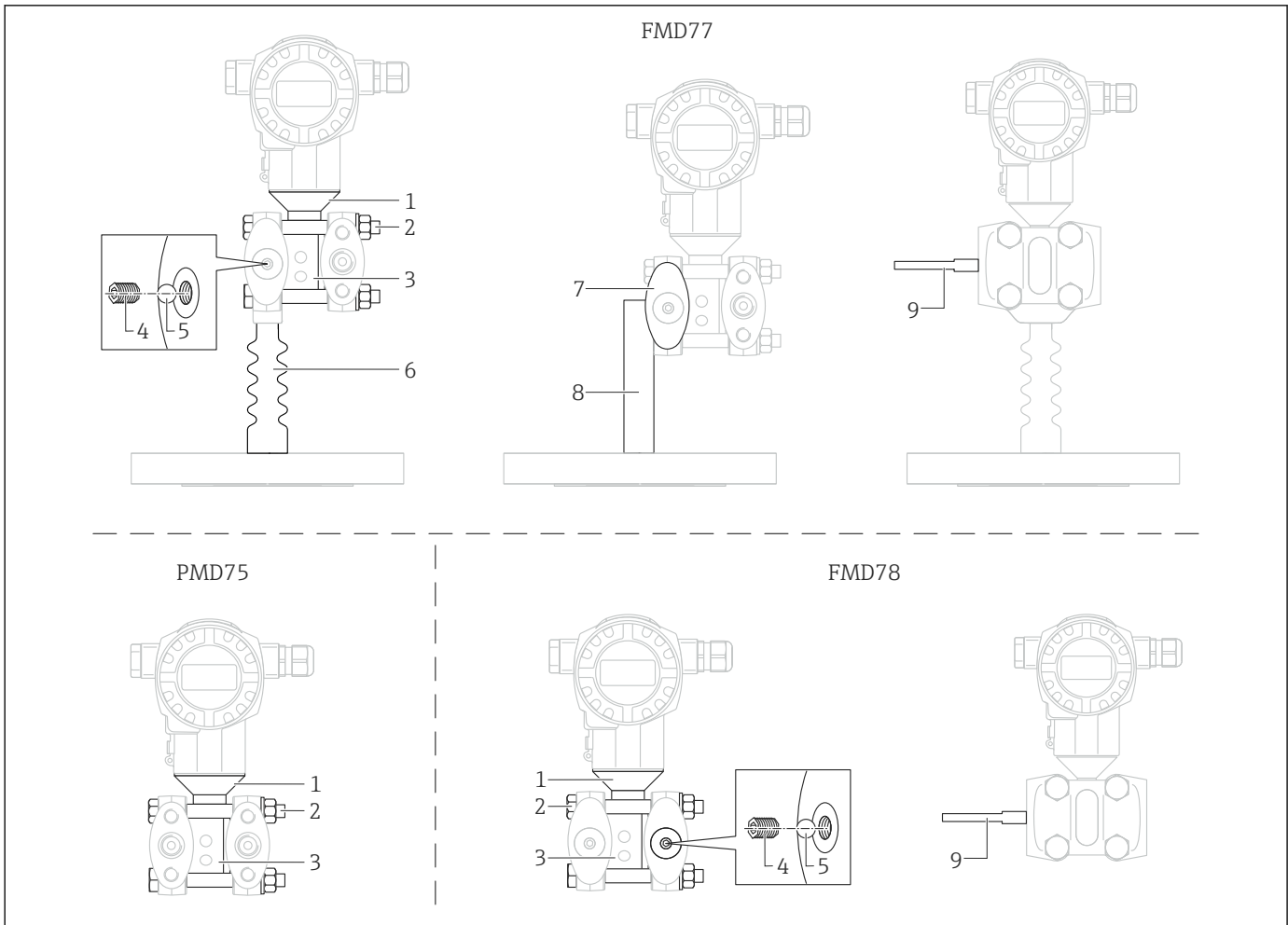

A0023955

Item number	Component part	Material
1	Connection between the housing and process connection	AISI 316L (1.4404)
2	Screw and nuts	PMD75 PN 160, FMD77, FMD78: <ul style="list-style-type: none"> <li>■ Hex.-headed bolt DIN 931-M12x90-A4-70</li> <li>■ Hex.-headed nut DIN 934-M12-A4-70</li> </ul> PMD75 PN 420: <ul style="list-style-type: none"> <li>■ Hex.-headed bolt ISO 4014-M12x90-A4</li> <li>■ Hex.-headed nut ISO 4032-M12-A4-bs</li> </ul>
3	Cell body	AISI 316L (1.4404)
4	Threaded pin	DIN 915 M 6x8 A2-70
5	Bearing	DIN 5401 (1.3505)
6	Temperature isolator	AISI 316L (1.4404)
7	Side flanges	1.4408 / CF3M <sup>1)</sup> / AISI 316L
8	U-bracket	AISI 304 (1.4301)
9	Heat-shrink tube (available only if flexible armor for capillary has PVC coating or PTFE hose)	Polyolefin

1) Cast equivalent to material AISI 316L

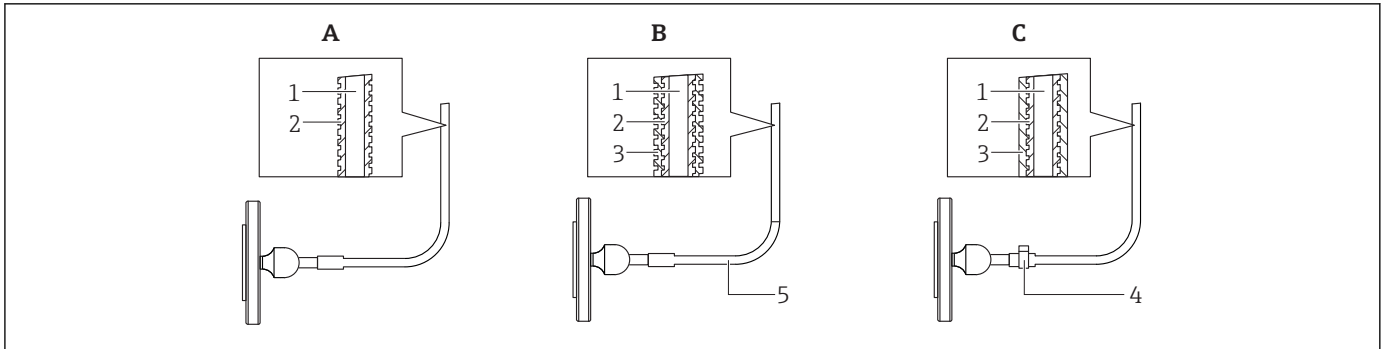

A0028087

Item	Component part	A Standard <sup>1)</sup> Armor for capillary	B PVC-coated Armor for capillary	C PTFE hose Armor for capillary
1	Capillary	AISI 316 Ti (1.4571)	AISI 316 Ti (1.4571)	AISI 316 Ti (1.4571)
2	Protective hose for capillary	AISI 316L (1.4404) <sup>2)</sup>	AISI 316L (1.4404)	AISI 316L (1.4404)
3	Coating/armor	-	PVC <sup>3)</sup>	PTFE <sup>4)</sup>
4	Single-ear clamp	-	-	1.4301
5	Shrink tubing at capillary junction	-	Polyolefin	-

- 1) If no option is specified when ordering, order option "SA" is supplied.
- 2) Product Configurator, order code for "Armor for capillary:" option "SA"
- 3) Product Configurator, order code for "Armor for capillary:" option "SB"
- 4) Product Configurator, order code for "Armor for capillary:" option "SC"

#### Materials in contact with process

#### NOTICE

- ▶ The device components in contact with the process are specified in the "Mechanical construction" → 46 and "Ordering information" → 108 sections.

#### Delta-ferrite content

A delta-ferrite content of  $\leq 3\%$  can be guaranteed and certified for the wetted parts of the FMD78 if option "8" is selected in the "Additional options 1" or "Additional options 2" order code in the Product Configurator.

#### TSE Certificate of Suitability (Transmissible Spongiform Encephalopathy)

The following applies to all device components in contact with the process:

- They do not contain any materials derived from animals.
- No additives or operating materials derived from animals are used in production or processing.

#### Process connections

- "Clamp connections" and "Hygienic process connections": AISI 316L (DIN/EN material number 1.4435)
- Endress+Hauser supplies DIN/ EN process connections with threaded connections made of stainless steel as per AISI 316L (DIN/EN material number 1.4404 or 14435). With regard to their stability-temperature property, the materials 1.4404 and 1.4435 are grouped together under 13EO in EN 1092-1: 2001 Tab. 18. The chemical composition of the two materials can be identical.
- Some process connections are also available in alloy C276 (DIN/EN material number 2.4819). For this purpose see the information in the "Mechanical construction" section.
- Side flanges: 316L, C 22.8 with zinc plating or alloy C 276. The C22.8 side flanges are coated with anti-corrosion protection (zinc, chrome). To prevent the formation of hydrogen and thereby diffusion through the membrane, Endress+Hauser recommends the use of 316L side flanges for applications involving water. Hydrogen diffusion through the membrane leads to measurement errors, or in extreme cases to a device failure.

## Process isolating diaphragm

Sensor	Designation	Option <sup>1)</sup>
<b>FMD77</b>	AISI 316L, TempC, high-pressure side (HP)	E
	AISI 316L with gold coating (25 µm), TempC, high-pressure side (HP) <sup>2)</sup>	D
	AISI 316L, high-pressure side (HP)	1
	Alloy C 276, high-pressure side (HP) <sup>3)</sup>	2
	Monel (2.4360), high-pressure side (HP) <sup>3)</sup>	3
	Tantalum (UNS R05200), high-pressure side (HP) <sup>3)</sup>	5
	AISI 316L with gold-rhodium coating, high-pressure side (HP)	6
	AISI 316L with 0.25 mm (0.01 in) PTFE coating, high-pressure side (HP)	8
<b>FMD77 with capillaries on low-pressure side (LP)</b>	AISI 316L, TempC, high-pressure side (HP) + low-pressure side (LP)	F
	AISI 316L with gold coating (25 µm), TempC, high-pressure side (HP) + low-pressure side (LP) <sup>2)</sup>	G
	AISI 316L, high-pressure side (HP) + low-pressure side (LP)	H
	Alloy C 276, high-pressure side (HP) + low-pressure side (LP)	J
	Monel (2.4360), high-pressure side (HP) + low-pressure side (LP)	K
	Tantalum (UNS R05200), high-pressure side (HP) + low-pressure side (LP)	L
	AISI 316L with gold-rhodium coating, high-pressure side (HP) + low-pressure side (LP)	M
	AISI 316L with 0.25 mm (0.01 in) PTFE coating, high-pressure side (HP) + low-pressure side (LP)	N
<b>FMD78</b>	AISI 316L with gold coating (25 µm), TempC <sup>2)</sup>	G
	AISI 316L, TempC	E
	AISI 316L	1
	Alloy C 276 <sup>3)</sup>	2
	Monel (2.4360) <sup>3)</sup>	3
	Tantalum (UNS R05200) <sup>3)</sup>	5
	AISI 316L with gold-rhodium coating	6
	AISI 316L with 0.25 mm (0.01 in) PTFE foil (FDA 21 CFR 177.1550)	8
<b>PMD75</b>	AISI 316L	1
	Alloy C 276 (2.4819)	2
	Monel (2.4360)	3
	Tantalum (UNS R05200)	5
	Alloy C 276 with gold-rhodium coating	6

- 1) Product Configurator, order code for "Membrane material"
- 2) The TempC gold-plated membrane does not offer corrosion protection!
- 3) The material used in the raised face of the flange is the same as that used in the process isolating diaphragm. For devices with a barrel (extended diaphragm seal), the flange raised face and the barrel pipe are made of 316L.

**Seals**

Device	Designation	Option <sup>1)</sup>
PMD75	FKM Viton	A
	PTFE (PN160bar/16MPa/2400psi)	C <sup>2)</sup>
	PTFE (PN250bar/25MPa/3625psi)	D <sup>2)</sup>
	NBR	F
	Copper seal ring	H
	Copper seal ring, oxygen service, observe pressure and temperature application limits	K
	FKM Viton, cleaned from oil and grease	1
	FKM Viton, cleaned for oxygen service, observe pressure and temperature application limits	2
	PTFE, cleaned for oxygen service, observe pressure and temperature application limits	3
	EPDM	J <sup>3)</sup>

- 1) Product Configurator, order code for "Seal"
- 2) Suitable for foodstuffs FDA21 CFR 177.1550
- 3) Suitable for drinking water NSF61.

**Fill fluid**

**FMD77: Diaphragm seal fill fluid**

Process connection	Designation	Option <sup>1) 2)</sup>
High-pressure side (HP)	Silicone oil (food-safe FDA 21 CFR 175.105)	A
	Vegetable oil (food-safe FDA 21 CFR 172.856)	D
	Inert oil	F
	Low-temperature oil	L
	High-temperature oil	V
Low-pressure side (LP)	..... m capillary, silicone oil (food-safe FDA 21 CFR 175.105)	M
	..... m capillary, vegetable oil (food-safe FDA 21 CFR 172.856)	N
	..... m capillary, inert oil	O
	..... m capillary; low-temperature oil	P
	..... m capillary; high-temperature oil	Q
	..... ft capillary, silicone oil (food-safe FDA 21 CFR 175.105)	R
	..... ft capillary, vegetable oil (food-safe FDA 21 CFR 172.856)	S
	..... ft capillary, inert oil	T
	..... ft capillary; low-temperature oil	U
	..... ft capillary; high-temperature oil	W

- 1) Product Configurator, order code for "Fill fluid"
- 2) For diaphragm seal devices with 3-A and EHEDG certificates, only select filling oils with FDA approval!

**FMD77: Pressure measuring cell fill fluid**

FMD77	Designation	Option <sup>1)</sup>
With capillary on low-pressure side (LP)	Silicone oil	Standard, if no option was selected.
	Inert oil, PWIS-free	HC
Without capillary on low-pressure side (LP)	Silicone oil	Standard, if no option was selected.

FMD77	Designation	Option <sup>1)</sup>
	Inert oil, cleaned for oxygen service	HB
	Inert oil, PWIS-free	HC

1) Product Configurator, order code for "Service"

#### FMD78: Diaphragm seal fill fluid

Capillary length;	Designation	Option <sup>1)</sup>
Symmetrical	.....ft capillary; silicone oil (food-safe FDA 21 CFR 175.105)	A <sup>2)</sup>
	..... ft capillary; vegetable oil (food-safe FDA 21 CFR 172.856)	B <sup>2)</sup>
	..... ft capillary; high-temperature oil	C <sup>2)</sup>
	..... ft capillary; inert oil, oxygen service, observe pressure/temp. application limits	D <sup>2)</sup>
	..... ft capillary; low-temperature oil	E <sup>2)</sup>
	..... ft capillary, inert oil	F <sup>2)</sup>
	..... m capillary; silicone oil (food-safe FDA 21 CFR 175.105)	1 <sup>2)</sup>
	..... m capillary; vegetable oil (food-safe FDA 21 CFR 172.856)	2 <sup>2)</sup>
	..... m capillary; high-temperature oil	3 <sup>2)</sup>
	..... m capillary; inert oil, oxygen service, observe pressure/temp. application limits	4 <sup>2)</sup>
	..... m capillary; low-temperature oil	5 <sup>2)</sup>
	..... m capillary, inert oil	6 <sup>2)</sup>
Asymmetrical Low-pressure side (LP) <sup>3)</sup>	..... m capillary, silicone oil (food-safe FDA 21 CFR 175.105), LP-side	M <sup>2)</sup>
	..... m capillary, vegetable oil (food-safe FDA 21 CFR 172.856), LP-side	N <sup>2)</sup>
	..... m capillary, inert oil, LP side	O <sup>2)</sup>
	..... m capillary, low-temperature oil, LP side	P <sup>2)</sup>
	..... m capillary, high-temperature oil, LP side	Q <sup>2)</sup>
	.....ft capillary, silicone oil (food-safe FDA 21 CFR 175.105), LP-side	R <sup>2)</sup>
	..... ft capillary; vegetable oil (food-safe FDA 21 CFR 172.856), LP-side	S <sup>2)</sup>
	..... ft capillary, inert oil, LP side	T <sup>2)</sup>
	..... ft capillary, low-temperature oil, LP side	U <sup>2)</sup>
	..... ft capillary, high-temperature oil, LP side	W <sup>2)</sup>
Asymmetrical High-pressure side (LP) <sup>4)</sup>	..... ft capillary, HP side	V <sup>5)</sup>
	..... m capillary, HP side	W <sup>5)</sup>

- 1) For diaphragm seal devices with 3-A and EHEDG certificates, only select filling oils with FDA approval!
- 2) Product Configurator, order code for "Fill fluid"
- 3) If the capillary length for asymmetrical LP or HP is identical, select a symmetrical capillary length when ordering.
- 4) If the capillary length for asymmetrical LP or HP is identical, select a symmetrical capillary length when ordering.
- 5) Product Configurator, order code for "Additional options 2"

**FMD78: Pressure measuring cell fill fluid**

Designation	Option <sup>1)</sup>
Silicone oil	Standard, if no option was selected.
Inert oil, PWIS-free	HC

1) Product Configurator, order code for "Service"

**PMD75: Pressure measuring cell fill fluid**

Designation	Option
Silicone oil	Standard, if no option was selected.
Inert oil, FKM Viton, oxygen service	2 <sup>1)</sup>
Inert oil, PTFE, oxygen service	3 <sup>1)</sup>
Inert oil, copper seal ring, oxygen service	K <sup>1)</sup>
Inert oil, PWIS-free	HC <sup>2)</sup>
Inert oil, cleaned for oxygen service	HB <sup>2)</sup>

1) Product Configurator, order code for "Seal"

2) Product Configurator, order code for "Service"

## Operability

### Operating concept

#### Operator-oriented menu structure for user-specific tasks

- Commissioning
- Operation
- Diagnosis

#### Quick and safe commissioning

Guided menus for applications

#### Reliable operation

- Local operation possible in several languages
- Standardized operation at the device and in the operating tools
- Parameters relating to measured values can be locked/unlocked using the device's write protection switch, using the device software or via remote operation

#### Efficient diagnostics increase measurement availability

- Remedial measures are integrated in plain text
- Diverse simulation options

### Local operation

#### Functions

Function	External operation (operating keys, optional, not T17 housing)	Internal operation (electronic insert)	Onsite display (optional)
Position adjustment (zero point correction)	✓	✓	✓
Setting lower range value and upper range value - reference pressure present at the device	✓ (HART only)	✓ (HART only)	✓
Device reset	✓	✓	✓
Locking and unlocking parameters relevant to the measured value	—	✓	✓
Value acceptance indicated by the green LED	✓	✓	✓
Switching damping on and off	✓ (only if display is connected)	✓ (HART and PA only)	✓
Configuring the bus address of the device (PA)	—	✓	✓
Switching simulation mode on and off (FOUNDATION Fieldbus)	—	✓	✓

#### Operating the device using onsite display (optional)

A 4-line liquid crystal display (LCD) is used for display and operation. The onsite display shows measured values, dialog text as well as fault and notice messages in plain text, thereby supporting the user in every stage of operation.

The display can be removed for easy operation.

The device display can be turned in 90° steps.

Depending on the installation position of the device, this makes it easy to operate the device and read the measured value.

Functions:

- 8-digit measured value display including sign and decimal point and bar graph for
  - 4 to 20 mA HART (bar graph from 4 to 20 mA)
  - PROFIBUS PA (bar graph as graphic display of standardized value of AI block)
  - FOUNDATION Fieldbus (bar graph as graphic display of transducer output).
- Simple and complete menu guidance due to breakdown of parameters into several levels and groups
- Menu guidance in up to 8 languages
- Each parameter is given a 3-digit ID number for easy navigation.
- Option for configuring the display according to individual requirements and preferences, such as language, alternating display, display of other measured values such as sensor temperature, contrast setting.
- Comprehensive diagnostic functions (fault and warning message, peak-hold indicators, etc.).
- Rapid and safe commissioning with the Quick Setup menus

Overview

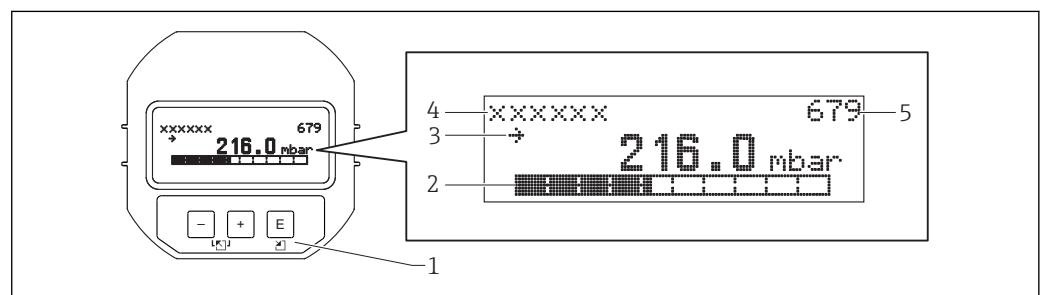

A0016498

- 1 Operating keys
- 2 Bargraph
- 3 Symbol
- 4 Header
- 5 Parameter ID number

Operating keys on the exterior of the device

With the aluminum housing (T14), the operating keys are located either outside on the housing, under the protection cap or inside on the electronic insert. With the stainless steel housing (T17), the operating keys are always located inside the housing on the electronic insert.

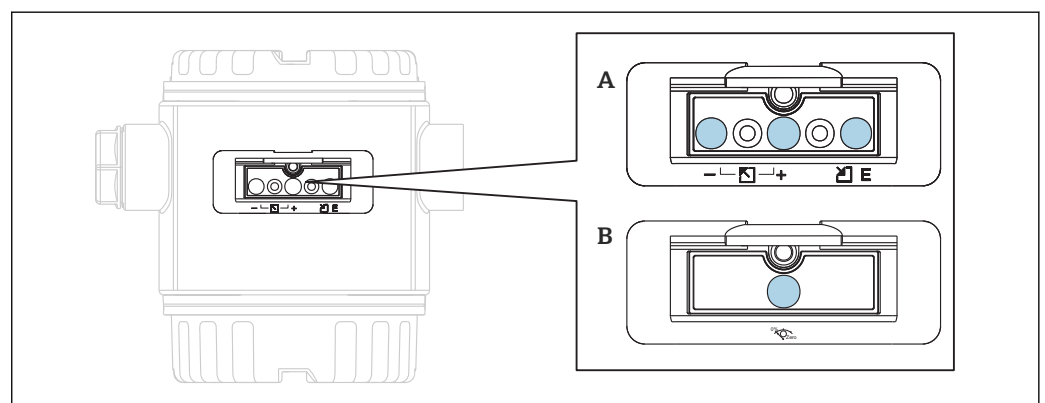

A0020030

- A 4 to 20 mA HART
- B PROFIBUS PA and FOUNDATION Fieldbus

The operating keys located externally on the device work on the Hall sensor principle. As a result, no additional openings are required in the device. This guarantees:

- Complete protection against environmental influences such as moisture and contamination.
- Simple operation without any tools.
- No wear.

Ordering information:

Product Configurator, order code for "Output, operation"

**Operating keys and elements located internally on the electronic insert**

Ordering information:

Product Configurator, order code for "Output, operation"

*HART*

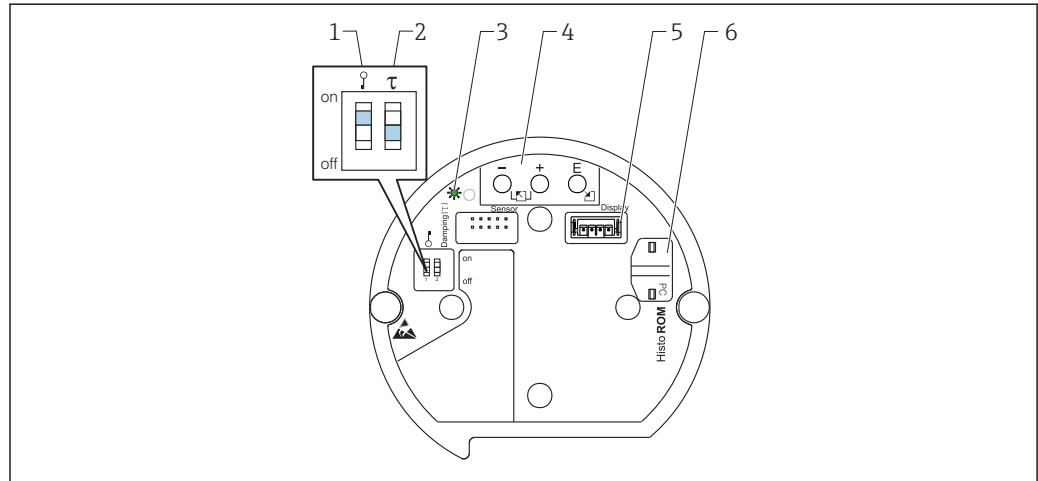

A0020031

- 1 *DIP switch for locking/unlocking parameters relevant to the measured value*
- 2 *DIP switch for switching damping on/off*
- 3 *Green LED to indicate value being accepted*
- 4 *Operating keys*
- 5 *Slot for optional display*
- 6 *Slot for optional HistoROM®/M-DAT*

*PROFIBUS PA*

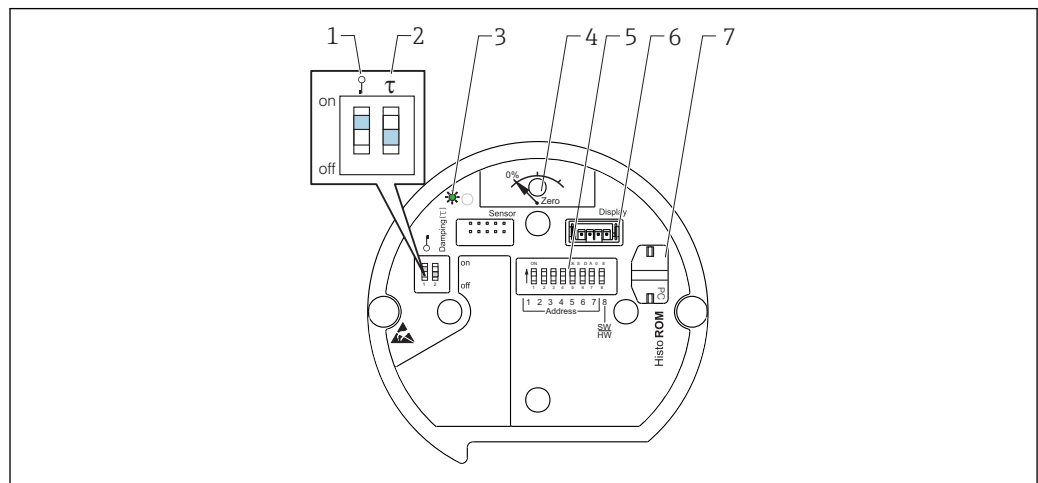

A0020032

- 1 *DIP switch for locking/unlocking parameters relevant to the measured value*
- 2 *DIP switch for switching damping on/off*
- 3 *Green LED to indicate value being accepted*
- 4 *Key for position adjustment and device reset*
- 5 *DIP switch for bus address*
- 6 *Slot for optional display*
- 7 *Slot for optional HistoROM®/M-DAT*

FOUNDATION Fieldbus

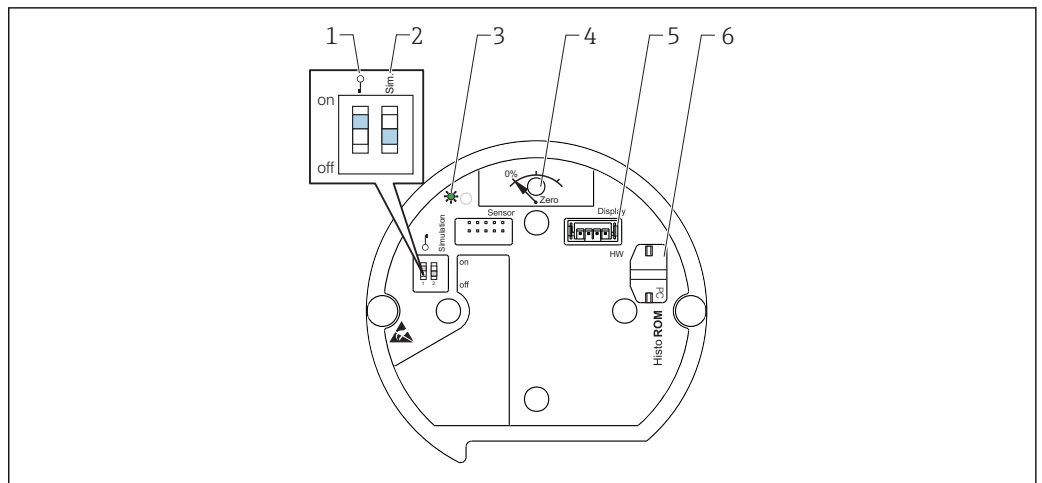

A0020033

- 1 DIP switch for locking/unlocking parameters relevant to the measured value
- 2 DIP switch for simulation mode on/off
- 3 Green LED to indicate value being accepted
- 4 Key for position adjustment and device reset
- 5 Slot for optional display
- 6 Slot for optional HistoROM®/M-DAT

Remote operation

All software parameters are accessible depending on the position of the write protection switch on the device.

Hardware and software for remote operation	HART	PROFIBUS PA	FOUNDATION Fieldbus
FieldCare	✓	✓	✓
FieldXpert SFX100	✓	—	✓
NI-FBUS Configurator	—	—	✓
HistoROM®/M-DAT	✓	✓	✓

FieldCare

FieldCare is an Endress+Hauser asset management tool based on FDT technology. With FieldCare, you can configure all Endress+Hauser devices as well as devices from other manufacturers that support the FDT standard.

FieldCare supports the following functions:

- Configuration of transmitters in offline and online mode
- Loading and saving device data (upload/download)
- HistoROM®/M-DAT analysis
- Documentation of the measuring point

Connection options:

- HART via Commubox FXA195 and USB interface of a computer
- PROFIBUS PA via segment coupler and PROFIBUS interface card
- Service interface with Commubox FXA291 and ToF adapter FXA291 (USB).



For further information, please contact your local Endress+Hauser Sales Center.

Field Xpert SFX100

Field Xpert is an industrial PDA with integrated 3.5" touchscreen from Endress+Hauser based on Windows Mobile. It offers wireless communication via the optional VIATOR Bluetooth modem from Endress+Hauser. Field Xpert also works as a stand-alone device for asset management applications. For details, refer to BA00060S/04/EN.

**Commubox FXA195**

For intrinsically safe HART communication with FieldCare via the USB interface. For details refer to TI00404F/00/EN.

**Commubox FXA291**

The Commubox FXA291 connects Endress+Hauser field devices with a CDI interface (=Endress +Hauser Common Data Interface) to the USB interface of a personal computer or a notebook. For details refer to TI00405C/07/EN.



For the following Endress+Hauser devices you need the "ToF adapter FXA291" as an additional accessory:

- Cerabar S PMC71, PMP7x
- Deltabar S PMD7x, FMD7x
- Deltapilot S FMB70

**ToF Adapter FXA291**

The ToF adapter FXA291 connects the Commubox FXA291 with devices of the ToF platform, pressure equipment and Gammapilot via the USB interface of a personal computer or a notebook. For details refer to KA00271F.

**Profiboard**

For connecting a PC to the PROFIBUS.

**Proficard**

For connecting a laptop to the PROFIBUS.

**FF configuration program**

FF configuration program, such as NI-FBUS Configurator, to

- connect devices with "FOUNDATION Fieldbus signal" into an FF-network
- set FF-specific parameters

*Operation with NI-FBUS Configurator:*

The NI-FBUS Configurator is an easy-to-use graphical environment for creating linkages, loops, and a schedule based on the fieldbus concepts.

You can use the NI-FBUS Configurator to configure a fieldbus network as follows:

- Set block and device tags
- Set device addresses
- Create and edit function block control strategies (function block applications)
- Configure vendor-defined function and transducer blocks
- Create and edit schedules
- Read and write to function block control strategies (function block applications)
- Invoke methods specified in the manufacturer-specific DD (e.g. basic device settings)
- Display DD menus (e.g. tab for calibration data)
- Download a configuration
- Verify a configuration and compare it to a saved configuration
- Monitor a downloaded configuration
- Replace devices
- Save and print a configuration

**HistoROM®/M-DAT (optional)**

HistoROM®/M-DAT is a memory module which can be attached to every electronic insert. HistoROM®/M-DAT can be retrofitted at any stage (order number: 52027785).

Your benefits

- Quick and safe commissioning of the same measuring points by copying the configuration data of one transmitter to another transmitter.
- Reliable process monitoring thanks to cyclical recording of pressure and sensor temperature measured values
- Simple diagnosis by recording diverse events such as alarms, configuration changes, counters for measuring range undershoot and overshoot for pressure and temperature as well as user limit overshoot and undershoot for pressure and temperature etc.
- Analysis and graphic evaluation of the events and process parameters via software (contained in scope of supply).

You can copy data from one transmitter to another transmitter when operating a FOUNDATION Fieldbus device via an FF configuration program. You need the Endress+Hauser FieldCare operating program, the Commubox FXA291 service interface and the ToF adapter FXA291 to be able to access the data and events saved in the HistoROM®/M-DAT.

Ordering information:

Product Configurator, order code for "Additional options:", version "N" or

Product Configurator, order code for "Application package:", option "EN" or

as a separate accessory (part no.: 52027785).



For further information, please contact your local Endress+Hauser Sales Center.

**System integration**

The device can be given a tag name (max. 8 alphanumeric characters).

Designation	Option <sup>1)</sup>
Measuring point (TAG), see additional specifications	Z1
Bus address, see additional spec.	Z2

1) Product Configurator, order code for "Identification"

## Planning instructions for diaphragm seal systems

### NOTICE

#### Diaphragm seal systems sized/ordered incorrectly

The performance and the permitted range of application of a diaphragm seal system depend on the process isolating diaphragm used, the filling oil, the coupling, the unit design and on the specific process and ambient conditions present in the individual application.

- ▶ To help you select the right diaphragm seal systems for your particular applications, Endress+Hauser provides its customers with the "Applicator Sizing Diaphragm Seal" selection tool, which is available free of charge at [www.endress.com/applicator](http://www.endress.com/applicator) or as a download.

The screenshot displays the 'Applicator Sizing Diaphragm Seal' web interface. The main configuration area is divided into several sections:

- General parameters:** Product (Deltabar S PMD75), TAG, and Order code (PMD75-1H61B3).
- Transmitter data:** Sensor (1bar/100kPa/15psi gauge), Adjusted span (14.504), Membrane material (316L), Process connection classes (All), Diaphragm seal (DN50 PN10-40 RT, 316L), Transmitter mounting (direct), and Fill fluid (Silicone oil).
- Measurement accuracy and offset:** % span / SDF and psi / SDF, Error due to change in process temperature (0.133, 0.019), and Error due to change in ambient temperature (0.202, 0.029).
- Calibration offset:** Maximum offset after installation (minimum: -0.1, nominal: 0, maximum: 0.1, unit: psi) and Zero offset (minimum: -0.4, nominal: 0, maximum: 0.6, unit: Negan).
- Process and ambient conditions:** Process temperature (minimum: 14, nominal: 77, maximum: 212, unit: °F), Ambient temperature (minimum: 14, nominal: 77, maximum: 140, unit: °F), and Static pressure (minimum: 13.053, nominal: 14.504, maximum: 29.008, unit: psi).
- Performance data:** Response time Tau (T63) (minimum: 0.2, nominal: 0.2, maximum: 0.2, unit: s) and Diaphragm deflection (minimum: -23, nominal: 0, maximum: 15, unit: %).

Buttons at the bottom include 'Print Sizing', 'Add to shop basket', 'Configurator', and 'Reset'.

A0034616

 For further details, or for information on an optimum diaphragm seal solution, please contact your local Endress+Hauser Sales Center.

### Applications

Diaphragm seal systems should be used if the process and the device need to be separated. Diaphragm seal systems offer clear advantages in the following instances:

- In the case of extreme process temperatures
- For aggressive media
- In the case of process media that crystallize
- In the case of corrosive or highly various process media or process media with solids content
- In the case of heterogeneous and fibrous process media
- If extreme measuring point cleaning is necessary, or in the event of very damp mounting locations
- If the measuring point is exposed to severe vibrations
- For mounting locations that are difficult to access

**Function and design**

Diaphragm seals separate the measuring system from the process.

A diaphragm seal system consists of:

- A diaphragm seal in a one-sided system, e.g. FMD77 or two diaphragm seals in a two-sided system, e.g. FMD78
- One capillary tube or two capillary tubes
- Fill fluid and
- A differential pressure transmitter

The process pressure acts via the process isolating diaphragm of the diaphragm seal on the liquid-filled system, which transfers the process pressure via the capillary tube onto the sensor of the differential pressure transmitter.

Endress+Hauser delivers all diaphragm seal systems as welded versions. The system is hermetically sealed, which ensures greater reliability.

The diaphragm seal determines the application range of the system on the basis of

- The diameter of the process isolating diaphragm
- The stiffness and material of the process isolating diaphragm
- The design (oil volume)

**Diameter of the process isolating diaphragm**

The greater the diameter of the process isolating diaphragm (less stiff), the smaller the temperature effect on the measurement result.

**Stiffness of the process isolating diaphragm**

The stiffness depends on the diameter of the process isolating diaphragm, the material, any existing coating, the thickness and shape of the process isolating diaphragm. The thickness of the process isolating diaphragm and the shape are determined by the design. The stiffness of a process isolating diaphragm of a diaphragm seal influences the temperature application range and the measuring error caused by temperature effects.

*The Endress+Hauser TempC Membrane: Highest accuracy and process safety when measuring pressure and differential pressure using diaphragm seals*

To measure with even greater accuracy in these applications and increase process safety, Endress +Hauser has developed the TempC Membrane which is based on a completely revolutionary technology. This diaphragm guarantees the utmost level of accuracy and process safety in diaphragm seal applications.

- The very low temperature effect minimizes the effect of process and ambient temperature fluctuations, thereby guaranteeing accurate and reliable measurements. Measurement inaccuracies caused by temperature are reduced to a minimum.
- The TempC Membrane can be used at temperatures between  $-70\text{ °C}$  ( $-94\text{ °F}$ ) and  $+400\text{ °C}$  ( $+752\text{ °F}$ ). This guarantees maximum process safety even for very long sterilization and cleaning cycles (SIP/CIP) in tanks and pipes at high temperatures.
- Smaller instrumentation dimensions are possible thanks to the TempC Membrane. With a smaller process connection, the new membrane measures at least as accurately as a conventional membrane with a larger diameter.
- Due to the geometry of the membrane, an overshoot occurs initially immediately following a temperature shock. This results in a transient response, the duration and deviation of which are significantly less compared to traditional membrane types. In the case of batch processes, these shorter recovery times mean a far higher level of availability of the production facilities. For TempC Membranes, the effect of the overshoot on the output signal can be reduced by adjusting the damping.

Ordering information:

See the Product Configurator for the individual process connection and the choice of process isolating diaphragm.

Selection in the Applicator:

Under "Transmitter data" in the "Membrane material" field.

**Capillary**

Diaphragm seals are used with the following capillary internal diameters as standard:

- $\leq$  DN 50: 1 mm (0.04 in)
- $>$  DN 50: 2 mm (0.08 in)

The capillary tube influences the thermal change, the ambient temperature operating range and the response time of a diaphragm seal system as a result of its length and internal diameter.

#### **Filling oil**

The medium and ambient temperatures as well as the process pressure are very important factors that must be considered when selecting the filling oil. Pay attention to the temperatures and pressures during commissioning and cleaning. Another selection criterion is the compatibility of the filling oil with the requirements of the medium. For example, only filling oils that do not present a health hazard may be used in the food industry, e.g. vegetable oil or silicone oil (see also the following section "Diaphragm seal filling oils").

The filling oil used influences the thermal change, the temperature application range of a diaphragm seal system and the response time. A temperature change results in a volume change in the filling oil. The volume change is dependent on the expansion coefficient and on the volume of the filling oil at calibration temperature (constant in range: +21 to +33 °C (+70 to +91 °F)). The application range can be extended by a filling oil with a lower expansion coefficient and a shorter capillary.

For example, the filling oil expands in the event of a temperature increase. The additional volume presses against the process isolating diaphragm of a diaphragm seal. The stiffer a process isolating diaphragm is, the greater its return force, which counteracts a volume change and acts together with the process pressure on the measuring cell, thus shifting the zero point.

---

#### **Differential pressure transmitter**

The differential pressure transmitter influences the temperature operating range, the TK zero point and the response time as a result of the volume of its side flange and as a result of its volume change. The volume change is the volume that has to be shifted in order to pass through the complete measuring range.

Differential pressure transmitters from Endress+Hauser are optimized with regard to the minimum volume change and side flange.

**Diaphragm seal filling oils**

Filling oil	Permissible temperature range <sup>1)</sup> at 0.05 bar (0.725 psi) ≤ p <sub>abs</sub> ≤ 1 bar (14.5 psi)	Permitted temperature range <sup>1)</sup> at p <sub>abs</sub> ≥ 1 bar (14.5 psi)	Option <sup>2)</sup>
Silicone oil	-40 to +180 °C (-40 to +356 °F)	-40 to +250 °C (-40 to +482 °F)	FMD77: A FMD78: A, 1
High-temperature oil	-10 to +200 °C (+14 to +392 °F)	-10 to +400 °C (+14 to +752 °F) <sup>3) 4) 5)</sup>	FMD77: V FMD78: C, 3
Inert oil	-40 to +80 °C (-40 to +176 °F)	-40 to +175 °C (-40 to +347 °F)	FMD77: F FMD78: D, 4
Vegetable oil	-10 to +120 °C (+14 to +248 °F)	-10 to +200 °C (+14 to +392 °F)	FMD77: D FMD78: B, 2
Low-temperature oil	-70 to +80 °C (-94 to +176 °F)	-70 to +180 °C (-94 to +356 °F)	FMD77: L FMD78: E, 5

- 1) Observe temperature limits of the device and of the system
- 2) Product Configurator, order code for "Fill fluid"
- 3) 325 °C (617 °F) at ≥ 1 bar (14.5 psi) absolute pressure.
- 4) 350 °C (662 °F) at ≥ 1 bar (14.5 psi) absolute pressure (max. 200 hours).
- 5) 400 °C (752 °F) at ≥ 1 bar (14.5 psi) absolute pressure (max. 10 hours).

*Additional data:*

Filling oil	Density [g/cm <sup>3</sup> ] / [SGU]	Viscosity [mm <sup>2</sup> /s] / [cSt] at 25 °C (77 °F)	Expansion coefficient <sup>1)</sup> [1/K]	Notes <sup>2)</sup>	Option <sup>3)</sup>
Silicone oil	0.96	100	0.00096	Suitable for foods FDA 21 CFR 175.105	FMD77: A FMD78: A, 1
High-temperature oil	1.00	150	0.00096	High temperatures	FMD77: V FMD78: C, 3
Inert oil	1.87	27	0.000876	For ultrapure gas and oxygen applications	FMD77: F FMD78: D, 4
Vegetable oil	0.94	9.5	0.00101	Suitable for foods FDA 21 CFR 172.856	FMD77: D FMD78: B, 2
Low-temperature oil	0.92	4.4	0.00108	Low temperatures	FMD77: L FMD78: E, 5

- 1) The thermal change in the diaphragm seal and other important technical features can be found in the "Applicator Sizing Diaphragm Seal" selection tool.
- 2) Only select FDA-approved filling oils for diaphragm seal devices with 3-A and EHEDG certification!
- 3) Product Configurator, order code for "Fill fluid"

**Operating temperature range** The operating temperature range of a diaphragm seal system depends on the fill fluid, capillary length and internal diameter, process temperature and oil volume of the diaphragm seal.  
The range of application can be extended by using a fill fluid with a smaller expansion coefficient and a shorter capillary.

**Response time**

The viscosity of the filling oil, the capillary length and the capillary internal diameter influence the frictional resistance. The greater the frictional resistance, the longer the response time. Furthermore, the volume change of the measuring cell influences the response time. The lower the volume change of the measuring cell, the less filling oil has to be shifted in the diaphragm seal system.

To help you select the right diaphragm seal systems for your particular applications, Endress+Hauser provides its customers with the "Applicator Sizing Diaphragm Seal" selection tool, which is available free of charge at [www.endress.com/applicator](http://www.endress.com/applicator) or can be ordered on a DVD.

**Cleaning instructions**

Endress+Hauser offers flushing rings as accessories to clean process isolating diaphragms without taking the transmitters out of the process.



For further information please contact your local Endress+Hauser Sales Center.

We recommend you perform CIP (cleaning in place (hot water)) before SIP (sterilization in place (steam)) for pipe diaphragm seals. The frequent use of sterilization in place (SIP) will increase the stress on the process isolating diaphragm. Under unfavorable circumstances, frequent temperature changes can lead - on the long term - to material fatigue of the process isolating diaphragm and possibly to a leakage.

**Installation instructions****Diaphragm seal systems**

- A diaphragm seal together with the transmitter form a closed, calibrated system, which is filled through openings in the diaphragm seal and in the transmitter's measurement system. These openings are sealed and must not be opened.
- In the case of devices with diaphragm seals and capillaries, the zero point shift caused by the hydrostatic pressure of the filling liquid column in the capillaries must be taken into account when selecting the measuring cell. If a measuring cell with a small measuring range is selected, the sensor nominal range can be overdriven as a result of position adjustment (see the figure and the example below).
- For devices with a capillary a suitable fastening device (mounting bracket) is recommended.
- When mounting, sufficient strain relief must be provided for the capillary line to prevent the capillary from bending (capillary bending radius  $\geq 100$  mm (3.94 in))
- For more detailed installation instructions, Endress+Hauser provides its customers with the free "Applicator Sizing Diaphragm Seal" selection tool, which is available online at [www.endress.com/applicator](http://www.endress.com/applicator) or as a download.

Selection of the measuring cell (observe the hydrostatic pressure of the filling liquid column in the capillaries!)

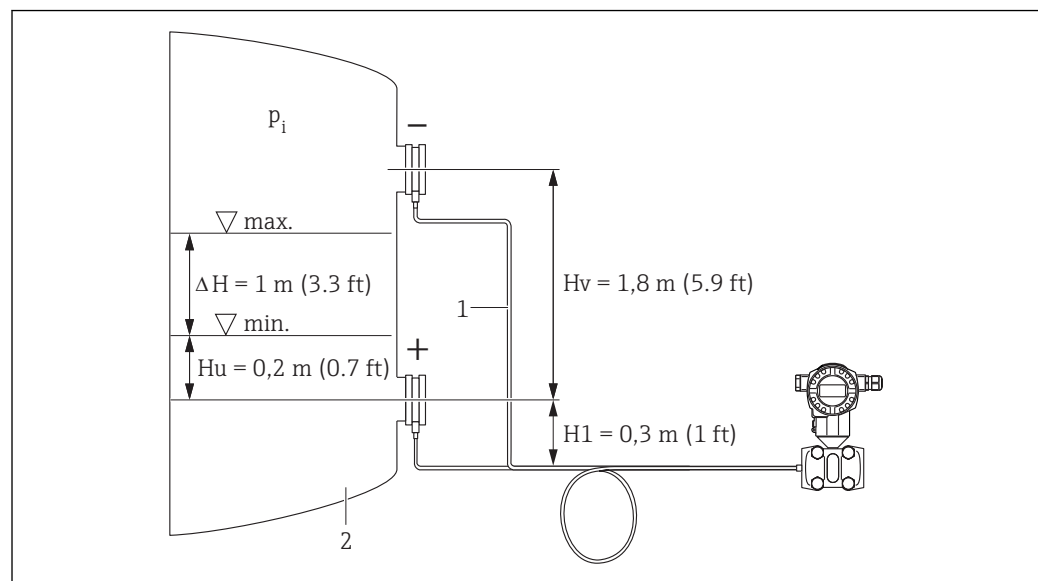

A0023961

- 1 Capillary with silicone oil:  $\rho_{FI} = 0.96$  kg (2.12 lb)  $dm^3$
- 2 Vessel with water:  $\rho_M = 1.0$  kg (2.21 lb)  $dm^3$

Pressure on the negative side of the differential pressure transmitter ( $p_-$ ) when the vessel is empty (minimum level):

$$\begin{aligned} p_- &= p_{HV} + p_{H1} = H_V \cdot \rho_{F1} \cdot g + H_1 \cdot \rho_{F1} \cdot g + p_i \\ &= 1,8 \text{ m} \cdot 0,96 \frac{\text{kg}}{\text{dm}^3} \cdot 9,81 \frac{\text{m}}{\text{s}^2} + 0,3 \text{ m} \cdot 0,96 \frac{\text{kg}}{\text{dm}^3} \cdot 9,81 \frac{\text{m}}{\text{s}^2} + p_i \\ &= 197,77 \text{ mbar} + p_i \end{aligned}$$

A0023962

Pressure on the positive side of the differential pressure transmitter ( $p_+$ ) when the vessel is empty (minimum level):

$$\begin{aligned} p_+ &= p_{HU} + p_{H1} = H_U \cdot \rho_M \cdot g + H_1 \cdot \rho_{F1} \cdot g + p_i \\ &= 0,2 \text{ m} \cdot 1 \frac{\text{kg}}{\text{dm}^3} \cdot 9,81 \frac{\text{m}}{\text{s}^2} + 0,3 \text{ m} \cdot 0,96 \frac{\text{kg}}{\text{dm}^3} \cdot 9,81 \frac{\text{m}}{\text{s}^2} + p_i \\ &= 47,87 \text{ mbar} + p_i \end{aligned}$$

A0023981

Differential pressure at the transmitter ( $\Delta p_{\text{transmitter}}$ ) when the vessel is empty:

$$\begin{aligned} \Delta p_{\text{Transmitter}} &= p_+ - p_- \\ &= 47,87 \text{ mbar} - 197,77 \text{ mbar} \\ &= -149,9 \text{ mbar} \end{aligned}$$

A0023982

Result:

When the vessel is full, a differential pressure of  $-51.80 \text{ mbar}$  ( $-0.762 \text{ psi}$ ) is present at the differential pressure transmitter. When the vessel is empty, a differential pressure of  $-149.90 \text{ mbar}$  ( $-2.2485 \text{ psi}$ ) is present. A  $500 \text{ mbar}$  ( $7.5 \text{ psi}$ ) measuring cell is therefore necessary for this application.

### Capillary

In order to obtain more precise measurement results and to avoid a defect in the device, mount the capillaries as follows:

- Vibration-free (in order to avoid additional pressure fluctuations)
- Not in the vicinity of heating or cooling lines
- Insulate if the ambient temperature is below or above the reference temperature
- With a bending radius  $\geq 100 \text{ mm}$  ( $3.94 \text{ in}$ )
- When using diaphragm seal systems with a capillary, sufficient strain relief must be provided to prevent the capillary from bending (capillary bending radius  $\geq 100 \text{ mm}$  ( $3.94 \text{ in}$ )).
- In the case of devices with diaphragm seals and capillaries, the zero point shift caused by the hydrostatic pressure of the filling liquid column in the capillaries must be taken into account when selecting the measuring cell. If a measuring cell with a small measuring range is selected, a position adjustment can cause range violation.

**Heat insulation – FMD77**

The FMD77 must only be insulated up to a certain height. The maximum permitted insulation height applies to an insulation material with a heat conductivity  $\leq 0.04 \text{ W}/(\text{m} \times \text{K})$  and to the maximum permitted ambient and process temperature. The data were determined under the most critical application "quiescent air".

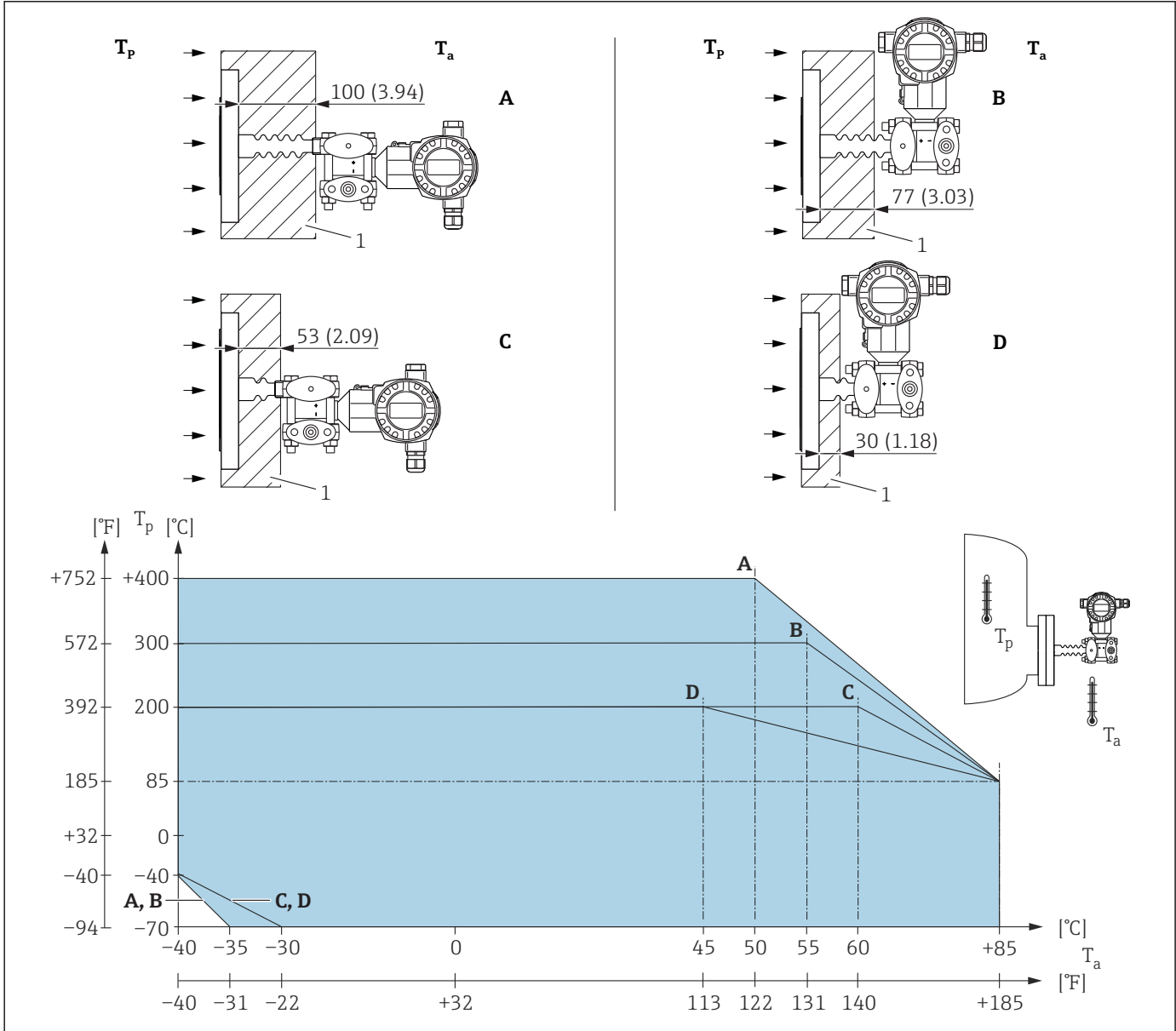

A0025889

1 Insulation material

Without insulation, the ambient temperature decreases by 5 K.

Item	Design	Temperature isolator	Option <sup>1)</sup>
A	Transmitter horizontal	long	MA <sup>2)</sup>
B	Transmitter vertical	long	MR
C	Transmitter horizontal	short	MC
D	Transmitter vertical	short	MD

1) Product Configurator, order code for "Design; temperature isolator"

2) Standard

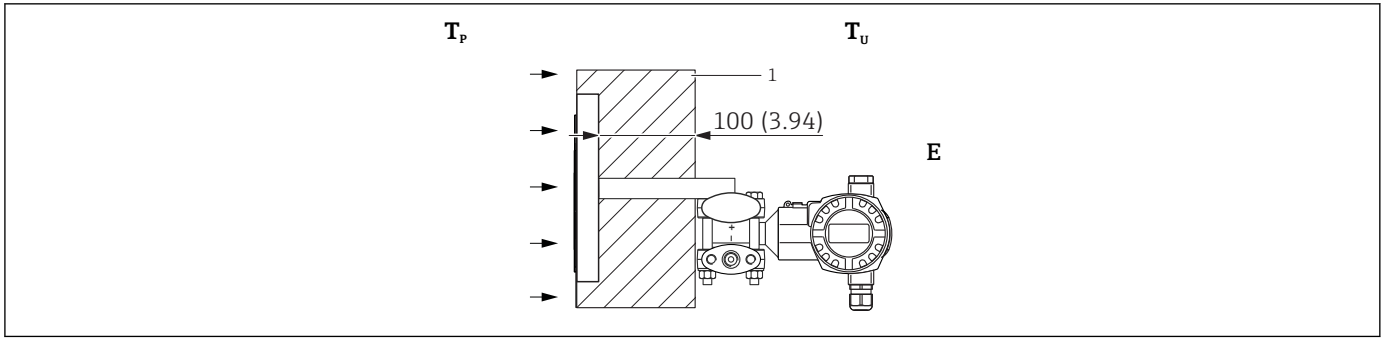

A0023984

1 Insulation material

Item	Design	Ambient temperature $T_A$	Process temperature $T_p$	Option <sup>1)</sup>
E	U-bracket, Transmitter horizontal (for devices which require a CRN approval)	$\leq 70$ °C (158 °F)	max. 350 °C (662 °F) depending on diaphragm seal filling oil used	<sup>2)</sup>

- 1) Product Configurator, order code for "Process connection"
- 2) In combination with CSA approval.

**Vacuum applications**

**Mounting instructions**

For applications under vacuum, Endress+Hauser recommends mounting the pressure transmitter below the lower diaphragm seal. This prevents a vacuum load of the diaphragm seal caused by the presence of filling oil in the capillaries.

When the pressure transmitter is mounted above the lower diaphragm seal, the maximum height difference  $H_1$ , in accordance with the following illustrations, must not be exceeded:

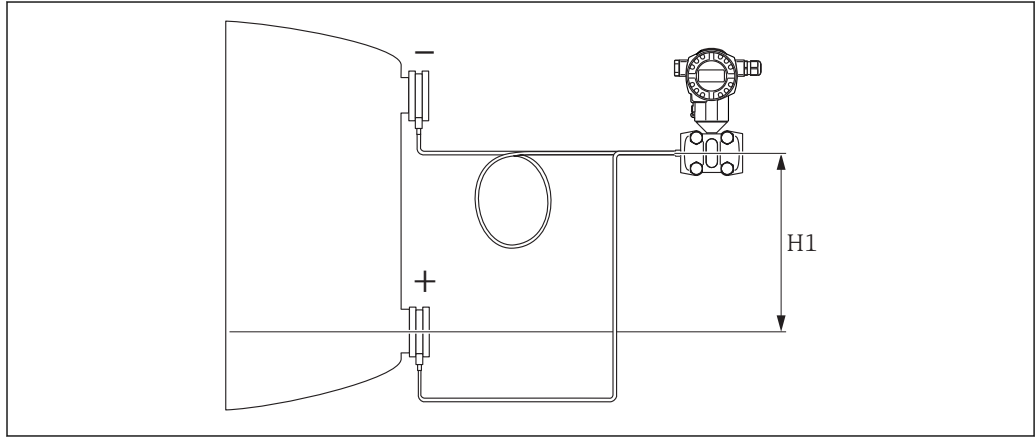

A0023983

The maximum height difference is dependent on the density of the filling oil and the lowest pressure that is ever allowed to occur at the diaphragm seal on the positive side (empty vessel), see the following illustration:

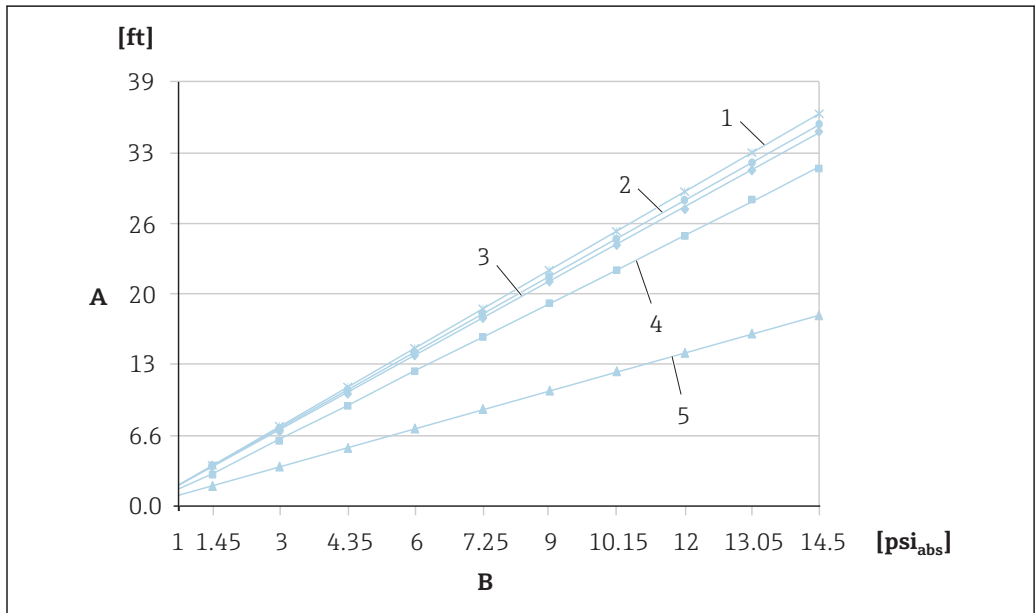

A0023986-EN

- A Height difference  $H_1$
- B Pressure at diaphragm seal
- 1 Low-temperature oil
- 2 Vegetable oil
- 3 Silicone oil
- 4 High-temperature oil
- 5 Inert oil

## Certificates and approvals

**CE mark** The device meets the legal requirements of the relevant EC directives. Endress+Hauser confirms that the device has been successfully tested by applying the CE mark.

**RCM-Tick marking** The supplied product or measuring system meets the ACMA (Australian Communications and Media Authority) requirements for network integrity, interoperability, performance characteristics as well as health and safety regulations. Here, especially the regulatory arrangements for electromagnetic compatibility are met. The products bear the RCM-Tick marking on the nameplate.



A0029561

**Ex approvals**

- ATEX
- FM
- CSA
- NEPSI
- IECEX
- GOST on request
- Also combinations of different approvals

All explosion protection data are given in separate documentation which is available upon request. The Ex documentation is supplied as standard with all Ex-devices → 114.

**EAC conformity** The measuring system meets the legal requirements of the applicable EAC guidelines. These are listed in the corresponding EAC Declaration of Conformity along with the standards applied. Endress+Hauser confirms successful testing of the device by affixing to it the EAC mark.

**Suitable for hygiene applications** The device has been developed for use in hygienic processes. The materials in contact with the process meet FDA requirements as well as the 3-A Sanitary Standard No. 74-XX. Endress+Hauser confirms compliance with the requirements by affixing the 3-A mark to the device. The following serial number-specific declarations (with a copy of the certification) can be ordered with the device (optional):  
Product Configurator, order code for "Additional approval" option "LD"  
Product Configurator, order code for "Additional approval" option "LB"

### NOTICE

#### Risk of contamination if incorrect seals and parts are used!

- ▶ To avoid the risk of contamination, the device must be installed in accordance with EHEDG "Hygienic Equipment Design Criteria (HDC)", "Subgroup Design Principles" Doc. 8.
- ▶ Suitable assemblies and seals must be used to ensure hygiene-compliant design according to the specifications of 3-A SSI and EHEDG Position Paper (in their current version).
- ▶ The leak-proof connections can be cleaned with industry-standard cleaning methods (CIP and SIP). Attention must be paid to the pressure and temperature specifications of the sensor and process connections for CIP (clean in place) and SIP (sterilization in place) processes.
- ▶ For diaphragm seal devices with 3-A and EHEDG certificates, only select filling oils with FDA approval!



A0026782

If cleaning in place (CIP) is required, adapters are available that comply with 3-A requirements. Information on 3-A and EHEDG-tested adapters can be found in the "Weld-in adapters, process adapters and flanges" documentation, TI00426F.

#### Certificate of current Good Manufacturing Practices (cGMP)

Product Configurator, order code for "Test, Certificate" option "JG"

- The certificate is only available in English
- Materials of construction of product wetted parts
- TSE compliance
- Polishing and surface finish
- Material/ compound compliance table (USP Class VI, FDA conformity)

#### Functional safety SIL/ IEC 61508 Declaration of Conformity (optional)

The Deltabar S with 4 to 20 mA output signal has been developed in accordance with the IEC 61508 standard. The device can be used for flow, level and differential pressure monitoring up to SIL 3. For a detailed description of the safety functions with the Deltabar S, settings and functional safety data, see the "Functional safety manual - Deltabar S" SD00189P.

For devices up to SIL 3 / IEC 61508 Declarations of Conformity see:

Ordering information:

Product Configurator, order code for "Additional options 1", version "E"

#### Overfill prevention

WHG (see document ZE00259P/00/EN)

Ordering information:

Product Configurator, order code for "Approval", option "6".

#### CRN approval

A CRN approval is available for some device versions. A CRN-approved process connection with a CSA approval must be ordered for a CRN-approved device. These devices are fitted with a separate plate bearing the registration number CRN 0F10524.5C.

Ordering information:

Product Configurator, order code for "Process connection; material" and

Product Configurator, order code for "Approval" (only in conjunction with an approved process connection)

#### Other standards and guidelines

The applicable European guidelines and standards can be found in the relevant EU Declarations of Conformity. The following standards were also applied:

##### IEC 62828-1 / DIN EN 60770 and IEC 62828-2 / DIN EN 60770:

Transmitters for use in industrial-process control systems. Part 1: Methods for inspection and routine testing

##### DIN 16086:

Electrical pressure measuring instruments, pressure sensors, pressure transmitters, pressure measuring instruments, concepts, specifications on data sheets

##### EN 61326-X:

EMC product family standard for electrical equipment for measurement, control and laboratory use.

**EN 60529:**

Degrees of protection provided by enclosures (IP code)

**Pressure Equipment Directive 2014/68/EU (PED)****Pressure equipment with allowable pressure  $\leq$  200 bar (2 900 psi)**

Pressure equipment (with a maximum allowable pressure  $PS \leq 200$  bar (2 900 psi)) can be classified as pressure accessories in accordance with Pressure Equipment Directive 2014/68/EU. If the maximum allowable pressure is  $\leq 200$  bar (2 900 psi) and the pressurized volume of the pressure equipment is  $\leq 0.1$  l, the pressure equipment is subject to the Pressure Equipment Directive (cf. Pressure Equipment Directive 2014/68/EU, Article 4, point 3). The Pressure Equipment Directive only requires that the pressure equipment shall be designed and manufactured in accordance with the "sound engineering practice of a Member State".

*Reasons:*

- Pressure Equipment Directive (PED) 2014/68/EU Article 4, point 3
- Pressure Equipment Directive 2014/68/EU, Commission's Working Group "Pressure", Guideline A-05 + A-06

*Note:*

A partial examination shall be performed for pressure instruments that are part of safety equipment for the protection of a pipe or vessel from exceeding allowable limits (safety accessory in accordance with Pressure Equipment Directive 2014/68/EU, Article 2, point 4).

**Pressure equipment with allowable pressure  $>$  200 bar (2 900 psi)**

Pressure equipment designated for application in every process fluid having a pressurized volume of  $<0.1$  l and a max. allowable pressure  $PS > 200$  bar (2 900 psi) must satisfy the essential safety requirements set out in Annex I of the Pressure Equipment Directive 2014/68/EU. According to Article 13 pressure equipment shall be classified by category in accordance with Annex II. Taking into account the low pressurized volume discussed above, the pressure devices are classed as category I pressure equipment. These devices must then bear the CE marking.

*Reasons:*

- Pressure Equipment Directive 2014/68/EU, Article 13, Annex II
- Pressure Equipment Directive 2014/68/EU, Commission's Working Group "Pressure", Guideline A-05

*Note:*

A partial examination shall be performed for pressure instruments that are part of safety equipment for the protection of a pipe or vessel from exceeding allowable limits (safety accessory in accordance with Pressure Equipment Directive 2014/68/EU, Article 2, point 4).

*The following also applies:*

- FMD78 with pipe diaphragm seal  $\geq 1.5$ "/PN40:  
Suitable for stable gases in group 1, category II, module A2
- PMD75, PN 420  
Suitable for stable gases in group 1, category I, module A

**Manufacturer declarations**

Depending on the desired configuration, the following documents can be ordered additionally with the device:

- FDA conformity
- TSE-free: materials free from animal origin
- Regulation (EC) No. 2023/2006 (GMP)
- Regulation (EC) No. 1935/2004 on materials and articles intended to come into contact with food

**Downloading the Declaration of Conformity**

[www.endress.com](http://www.endress.com) → Download

**Marine approval**

- GL: FMD78, PMD75
- ABS: FMD78, PMD75

Ordering information:

Product Configurator, order code for "Additional options 1" or "Additional options 2", version "S".

### Classification of process sealing between electrical systems and (flammable or combustible) process fluids in accordance with ANSI/ISA 12.27.01

Endress+Hauser devices are designed in accordance with ANSI/ISA 12.27.01, allowing the user to waive the use of - and save the cost of installing - external secondary process seals in the conduit as required by the process sealing sections of ANSI/NFPA 70 (NEC) and CSA 22.1 (CEC). These instruments comply with the North-American installation practice and provide a very safe and cost-saving installation for pressurized applications with hazardous fluids. Please refer to the following table for the seal class assigned (single seal or dual seal):

Device	Approval	Single seal MWP
PMD75	CSA C/US IS, XP	420 bar (6 300 psi)
FMD77	CSA C/US IS, XP	160 bar (2 400 psi)
FMD78	CSA C/US IS, XP	160 bar (2 400 psi)

Further information can be found in the control drawings of the relevant devices.

### Inspection certificate

Designation	FMD77	FMD78	PMD75	Option
3.1 Material documentation, wetted metal parts, EN10204-3.1 inspection certificate	✓	✓	✓	B <sup>1) 4)</sup>
Conformity to NACE MR0175, wetted metallic parts	✓	✓	✓	C <sup>1) 4)</sup>
EN10204-3.1 material, NACE MR0175, wetted metal parts, inspection certificate	✓	✓	✓	D <sup>1) 4)</sup>
Individual test, test report	✓	✓	✓	3 <sup>1) 2)</sup>
Pressure test, internal procedure, test report	✓	✓	✓	4 <sup>1) 2)</sup>
EN10204-3.1 material wetted parts +Ra, Ra= surface roughness, dimensional check, inspection certificate	—	✓	—	6 <sup>1) 2)</sup>
Delta-Ferrite measurement, internal procedure, wetted metallic parts, inspection certificate	—	✓	—	8 <sup>1) 2)</sup>
3.1 Material documentation, wetted metal parts, EN10204-3.1 inspection certificate	✓	✓	✓	JA <sup>3) 4)</sup>
Conformity to NACE MR0175, wetted metallic parts	✓	✓	✓	JB <sup>3) 4)</sup>
Conformity to NACE MR0103, wetted metallic parts	✓	✓	✓	JE <sup>3) 4)</sup>
Helium leak test, internal procedure, inspection certificate	✓	✓	✓	KD <sup>3)</sup>
Pressure test, internal procedure, inspection certificate	✓	✓	✓	KE <sup>3)</sup>
PMI test (XRF), internal procedure, metal parts in contact with the medium	✓	✓	✓	KG <sup>3)</sup>
Welding documentation, wetted/pressurized seams	—	✓	—	KS

- 1) Product Configurator, order code for "Additional options 1"
- 2) Product Configurator, order code for "Additional options 2"
- 3) Product Configurator, order code for "Test, Certificate"
- 4) The choice of this feature for coated process isolating diaphragms/process connections refers to the metal base material.

### Calibration

Designation	FMD77	FMD78	PMD75	Option <sup>1)</sup>
Nominal range; mbar/bar	✓	✓	✓	1
Nominal range; kPa/MPa	✓	✓	✓	2
Nominal range; mmH <sub>2</sub> O/mH <sub>2</sub> O	✓	✓	✓	3
Nominal range; inH <sub>2</sub> O/ftH <sub>2</sub> O	✓	✓	✓	4
Nominal range; psi	✓	✓	✓	6
Factory calibration certificate, 5-point; see additional specification	✓	✓	✓	C
DKD/DAkkS certificate; see additional specification	✓	✓	✓	D
Customized pressure; see additional specification	✓	✓	✓	E

Designation	FMD77	FMD78	PMD75	Option <sup>1)</sup>
Customized level; see additional specification	✓	✓	✓	F
Customized flow; see additional specification	–	–	✓	G
Customized pressure + 5-point factory calibration certificate; see additional specification	✓	✓	✓	H
Customized level + 5-point factory calibration certificate; see additional specification	✓	✓	✓	I
Customized flow + 5-point factory calibration certificate; see additional specification	✓	✓	✓	J
Platinum; see additional specification	–	–	✓	K
Platinum + factory calibration certificate 5-point; see additional specification	–	–	✓	L
Platinum + DKD/DAkkS certificate; see additional specification	–	–	✓	M

1) Product Configurator, order code for "Calibration; unit"

**Service**

Designation	Option <sup>1)</sup>
Cleaned of oil+grease <sup>2)</sup>	HA
Cleaned for oxygen service <sup>2)</sup>	HB
Cleaned of PWIS (paint-wetting impairment substances) <sup>2)</sup>	HC

- 1) Product Configurator, order code for "Service"  
 2) Device only, not accessories or enclosed accessories.

## Ordering information

Detailed ordering information is available from the following sources:

- In the Product Configurator on the Endress+Hauser website: [www.endress.com](http://www.endress.com) -> Click "Corporate" -> Select your country -> Click "Products" -> Select the product using the filters and search field -> Open product page -> The "Configure" button to the right of the product image opens the Product Configurator.
- From your Endress+Hauser Sales Center: [www.addresses.endress.com](http://www.addresses.endress.com)



### Product Configurator - the tool for individual product configuration

- Up-to-the-minute configuration data
  - Depending on the device: Direct input of measuring point-specific information such as measuring range or operating language
  - Automatic verification of exclusion criteria
  - Automatic creation of the order code and its breakdown in PDF or Excel output format
  - Ability to order directly in the Endress+Hauser Online Shop

### Special device versions

Endress+Hauser offers special device versions as **Technical Special Products (TSP)**.

For further information please contact your local Endress+Hauser Sales Center.

### Scope of delivery

- Measuring device
- Optional accessories
- Brief Operating Instructions
- Calibration certificates
- Optional certificates

### Measuring point (TAG)

<b>Order code</b>	895: Marking
<b>Option</b>	Z1: Tagging (TAG), see additional spec.
<b>Position of the measuring point marking</b>	To be selected in the additional specifications: <ul style="list-style-type: none"> <li>▪ Tag plate Stainless Steel</li> <li>▪ Self-adhesive paper label</li> <li>▪ Supplied label/plate</li> <li>▪ RFID TAG</li> <li>▪ RFID TAG + Tag plate Stainless Steel</li> <li>▪ RFID TAG + Self-adhesive paper label</li> <li>▪ RFID TAG + Supplied label/plate</li> </ul>
<b>Definition of the measuring point designation</b>	To be defined in the additional specifications: 3 lines containing up to 18 characters each  The measuring point designation appears on the selected label and/or the RFID TAG.
<b>Identification on electronic nameplate (ENP)</b>	32 characters

**Configuration data sheet**

**Pressure**

The following configuration data sheet must be completed and included with the order if the option "E" or "H" has been selected in the Product Configurator, order code for "Calibration; Unit".

Pressure unit				
<input type="checkbox"/> mbar	<input type="checkbox"/> mmH <sub>2</sub> O <sup>1)</sup>	<input type="checkbox"/> mmHg <sup>2)</sup>	<input type="checkbox"/> Pascals	<input type="checkbox"/> torr
<input type="checkbox"/> bar	<input type="checkbox"/> mH <sub>2</sub> O <sup>1)</sup>	<input type="checkbox"/> inHg <sup>2)</sup>	<input type="checkbox"/> hPa	<input type="checkbox"/> g/cm <sup>2</sup>
<input type="checkbox"/> psi	<input type="checkbox"/> ftH <sub>2</sub> O <sup>1)</sup>	<input type="checkbox"/> gf/cm <sup>2</sup>	<input type="checkbox"/> kPa	<input type="checkbox"/> kg/cm <sup>2</sup>
	<input type="checkbox"/> inH <sub>2</sub> O <sup>1)</sup>	<input type="checkbox"/> kgf/cm <sup>2</sup>	<input type="checkbox"/> MPa	<input type="checkbox"/> lb/ft <sup>2</sup>
				<input type="checkbox"/> atm

- 1) The conversion factor for the pressure unit is based on a reference temperature of 4 °C (39.2 °F).
- 2) The conversion factor of the pressure unit refers to a reference temperature of 0 °C (32 °F).

Calibration Range / Output	
Low range value (LRV):	_____ [Pressure engineering unit]
Upper range value (URV):	_____ [Pressure engineering unit]

Display
Display of the content of the main line (option depends on sensor and communication variant)
<input type="checkbox"/> Primary value [PV] (default)
<input type="checkbox"/> Main Value [%]
<input type="checkbox"/> Pressure
<input type="checkbox"/> Current [mA] (HART only)
<input type="checkbox"/> Temperature
<input type="checkbox"/> Error number
<input type="checkbox"/> Alternating display

Damping
Damping: _____ sec (Default 2 sec)

Smallest calibratable span (preset at factory) →  12

**Level**

The following configuration data sheet must be completed and included with the order if the option "F" or "T" has been selected in the Product Configurator, order code for "Calibration; Unit".

Pressure unit				Output unit (scaled unit)					
<input type="checkbox"/> mbar	<input type="checkbox"/> mmH <sub>2</sub> O <sup>1)</sup>	<input type="checkbox"/> mmHg <sup>2)</sup>	<input type="checkbox"/> Pascals	<input type="checkbox"/> torr	Mass	Lengths	Volume	Volume	Percent
<input type="checkbox"/> bar	<input type="checkbox"/> mH <sub>2</sub> O <sup>1)</sup>	<input type="checkbox"/> inHg <sup>2)</sup>	<input type="checkbox"/> hPa	<input type="checkbox"/> g/cm <sup>2</sup>	<input type="checkbox"/> kg	<input type="checkbox"/> m	<input type="checkbox"/> l	<input type="checkbox"/> USgal	<input type="checkbox"/> %
<input type="checkbox"/> psi	<input type="checkbox"/> ftH <sub>2</sub> O <sup>1)</sup>	<input type="checkbox"/> gf/cm <sup>2</sup>	<input type="checkbox"/> kPa	<input type="checkbox"/> kg/cm <sup>2</sup>	<input type="checkbox"/> t	<input type="checkbox"/> dm	<input type="checkbox"/> hl	<input type="checkbox"/> impgal	
	<input type="checkbox"/> inH <sub>2</sub> O <sup>1)</sup>	<input type="checkbox"/> kgf/cm <sup>2</sup>	<input type="checkbox"/> MPa	<input type="checkbox"/> lb/ft <sup>2</sup>	<input type="checkbox"/> lb	<input type="checkbox"/> cm	<input type="checkbox"/> m <sup>3</sup>	<input type="checkbox"/> USbbiPE	
				<input type="checkbox"/> atm		<input type="checkbox"/> mm	<input type="checkbox"/> ft <sup>3</sup>	TR	
						<input type="checkbox"/> ft			
						<input type="checkbox"/> inch			
Empty calibration [a]: Low pressure value (empty)			_____ [Pressure engineering unit]	Empty calibration [a]: Low level value (empty)			_____ [Scaled Unit]		
Full calibration [b]: High pressure value (full)			_____ [Pressure engineering unit]	Full calibration [b]: High level value (full)			_____ [Scaled Unit]		

**Example**

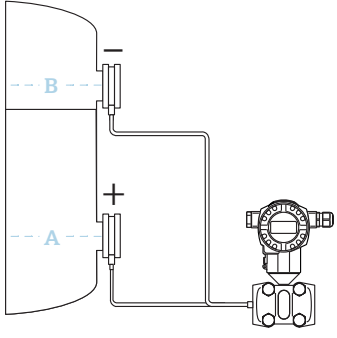

A0023985

A 500 mbar (7.25 psi) / 100 m<sup>3</sup>  
 B 50 mbar (1 psi) / 3 m<sup>3</sup>

- 1) The conversion factor for the pressure unit is based on a reference temperature of 4 °C (39.2 °F).
- 2) The conversion factor of the pressure unit refers to a reference temperature of 0 °C (32 °F).

Display
Display of the content of the main line (option depends on sensor and communication variant)
<input type="checkbox"/> Primary value [PV] (default)
<input type="checkbox"/> Main Value [%]
<input type="checkbox"/> Pressure
<input type="checkbox"/> Current [mA] (HART only)
<input type="checkbox"/> Temperature
<input type="checkbox"/> Level before Lin.
<input type="checkbox"/> Tank content
<input type="checkbox"/> Error number
<input type="checkbox"/> Alternating display

Damping
Damping: _____ sec (Default 2 sec)



Damping	
Damping:	_____ sec (Default 2 sec)

## Accessories



**HistoROM®/M-DAT** The HistoROM®/M-DAT is a memory module that can be attached to any electronic insert.  
 Ordering information:  
 Product Configurator, order code for "Additional options 1" or Additional options 2", version "N" or as a separate accessory (part no.: 52027785).

**Welding flanges and weld-in adapters** For details, refer to TI00426F/00/EN "Weld-in adapters, process adapters and flanges".

**Manifolds** See the →  52.  
 For further details, see SD01553P/00/EN "Mechanical accessories for pressure measuring devices".

**Additional mechanical accessories** Oval flange adapters, pressure gauge valves, shutoff valves, siphons, condensate pots, cable shortening kits, test adapters, mounting brackets, flushing rings, block&bleed valves and protective roofs.  
 For details see SD01553P/00/EN "Mechanical accessories for pressure measuring devices".

**Service-specific accessories**

Accessories	Description
DeviceCare SFE100	Configuration tool for HART, PROFIBUS and FOUNDATION Fieldbus field devices  Technical Information TI01134S  DeviceCare is available for download at <a href="http://www.software-products.endress.com">www.software-products.endress.com</a> . You need to register in the Endress+Hauser software portal to download the application.
FieldCare SFE500	FDT-based plant asset management tool FieldCare can configure all smart field units in your plant and helps you manage them. By using the status information, FieldCare is also a simple but effective way of checking the status and condition of the field devices.  Technical Information TI00028S

## Supplementary documentation

<b>Field of Activities</b>	Pressure measurement, powerful instruments for process pressure, differential pressure, level and flow: FA00004P/00/EN
----------------------------	---

<b>Technical Information</b>	Deltabar S: TI00382P/00/EN <ul style="list-style-type: none"> <li>▪ EMC test procedures: TI00241F/00/EN</li> <li>▪ Weld-in adapter, adapter and flanges: TI00426F/00/EN</li> </ul>
------------------------------	--

<b>Special Documentation</b>	Mechanical accessories for pressure measuring devices: SD01553P/00/EN
------------------------------	---

<b>Operating Instructions</b>	<p>4 to 20 mA HART:</p> <ul style="list-style-type: none"> <li>▪ Deltabar S: BA00270P/00/EN</li> <li>▪ Description of Device Functions Cerabar S/Deltabar S/Deltapilot S: BA00274P/00/EN</li> </ul> <p>PROFIBUS PA:</p> <ul style="list-style-type: none"> <li>▪ Deltabar S: BA00294P/00/EN</li> <li>▪ Description of Device Functions CerabarS/Deltabar S/Deltapilot S: BA00296P/00/EN</li> </ul> <p>FOUNDATION Fieldbus:</p> <ul style="list-style-type: none"> <li>▪ Deltabar S: BA00301P/00/EN</li> <li>▪ Description of Device Functions Cerabar S/Deltabar S/Deltapilot S: BA00303P/00/EN</li> </ul>
-------------------------------	--

<b>Brief Operating Instructions</b>	<ul style="list-style-type: none"> <li>▪ 4 to 20 mA HART, Deltabar S: KA01018P/00/EN</li> <li>▪ PROFIBUS PA, Deltabar S: KA01021P/00/EN</li> <li>▪ FOUNDATION Fieldbus, Deltabar S: KA01024P/00/EN</li> </ul>
-------------------------------------	---

<b>Functional safety manual (SIL)</b>	Deltabar S (4 to 20 mA): SD00189P/00/EN
---------------------------------------	---

<b>Overfill prevention</b>	WHG: ZE00259P/00/DE
----------------------------	---------------------

<b>Safety Instructions (XA)</b>	Depending on the approval, the following Safety Instructions (XA) are supplied with the device. They are an integral part of the Operating Instructions.
---------------------------------	--

Directive	Electronic insert	Documentation	Option <sup>1)</sup>
ATEX II 1/2G Ex ia IIC T6 Ga/Gb (WHG)	4 to 20 mA HART, PROFIBUS PA, FOUNDATION Fieldbus	XA00235P	1 (6)
ATEX II 1/2D Ex ta/tb IIIC Da/Db	4 to 20 mA HART	XA00237P	2
	PROFIBUS PA, FOUNDATION Fieldbus	XA00280P	
ATEX II 1/3D Ex ta IIIC Da/Dc	4 to 20 mA HART	XA00239P	4
	PROFIBUS PA, FOUNDATION Fieldbus	XA00282P	
ATEX II 2 G Ex d IIC T6 Gb	4 to 20 mA HART, PROFIBUS PA, FOUNDATION Fieldbus	XA00240P	5
ATEX II 3 G Ex nA II T6	4 to 20 mA HART, PROFIBUS PA, FOUNDATION Fieldbus	XA00241P	7
ATEX II 1/2G Ex ia IIC T6 Ga/Gb + ATEX II 1/2D Ex ia IIIC Da/Db	4 to 20 mA HART, PROFIBUS PA, FOUNDATION Fieldbus	XA00243P	3
ATEX II 1G Ex ia + II 1D Ex iaD	4 to 20 mA HART, PROFIBUS PA, FOUNDATION Fieldbus	XA00275P	8
ATEX II 1/2G Ex ia IIC T6+II 2G Ex d IIC T6	4 to 20 mA HART, PROFIBUS PA, FOUNDATION Fieldbus	XA00242P	B
ATEX II Ex ia/Ex d + FM/CSA IS + XP ATEX II 1/2G Ex ia IIC T6+ ATEX II 2G Ex d IIC T6+FM/CSA IS + XP Cl.I.II Div.1 Gr.A-G/B-GFM/CSA: Zone 1,2	4 to 20 mA HART	XA00242P ZD00153P XA01196P	F

Directive	Electronic insert	Documentation	Option <sup>1)</sup>
	PROFIBUS PA, FOUNDATION Fieldbus	XA00242P XA01198P ZD00191P	
IECEX Ex ia IIC T6 Ga/Gb	4 to 20 mA HART, PROFIBUS PA, FOUNDATION Fieldbus	XB00004P	I
IEC Ex d IIC T6 Gb	4 to 20 mA HART, PROFIBUS PA, FOUNDATION Fieldbus	XA00512P	M
NEPSI Ex ia IIC T6	4 to 20 mA HART, PROFIBUS PA, FOUNDATION Fieldbus	XA00550P	H
NEPSI Ex d IIC T6	4 to 20 mA HART, PROFIBUS PA, FOUNDATION Fieldbus	XA00552P	G

1) Product Configurator, order code for "Approval"

Directive	Electronic insert	Documentation	Option <sup>1)</sup>
INMETRO Ex ia IIC T6 Ga/Gb	4 to 20 mA HART, PROFIBUS PA, FOUNDATION Fieldbus	XA01318P	J
INMETRO Ex d IIC T6 Gb	4 to 20 mA HART, PROFIBUS PA, FOUNDATION Fieldbus	XA01281P	O
INMETRO Ex ta IIIC Da/Db	4 to 20 mA HART, PROFIBUS PA, FOUNDATION Fieldbus	XA01316P	Z

1) Product Configurator, order code for "Approval"

### Installation/Control

#### Drawings

Directive	Electronic insert	Documentation	Option <sup>1)</sup>
FM IS Cl.I,II,III Div.1 Gr.A-G, NI Cl.I Div.2 Gr.A-D, AEx ia, Zone 0,1,2,20,21,22	4 to 20 mA HART	XA01058P	S
	PROFIBUS PA, FOUNDATION Fieldbus	XA01060P	
FM/CSA IS + XP Cl.I Div.1 Gr.A-D, FM/CSA: Zone 1,2	4 to 20 mA HART	XA00591P XA01196P	Q
	PROFIBUS PA, FOUNDATION Fieldbus	XA00590P XA01198P	
FM DIP Cl.II,III Div.1 Gr.E-G, Zone 21,22	4 to 20 mA HART, PROFIBUS PA, FOUNDATION Fieldbus	FM3017778	Q
CSA C/US IS Cl.I,II,III Div.1 Gr.A-G, Cl.I Div.2 Gr.A-D, Ex ia, C: Zone 0,1,2/ US: Zone 0,1,2,20,21,22	4 to 20 mA HART	ZD00142P	U
	PROFIBUS PA, FOUNDATION Fieldbus	ZD00189P	
FM IS + XP Cl.I Div.1 Gr.A-D, Zone 1,2	4 to 20 mA HART	XA01196P	C
	PROFIBUS PA, FOUNDATION Fieldbus	XA01198P	
FM NI Cl.I Div.2 Gr.A-D, Zone 2	4 to 20 mA HART, PROFIBUS PA, FOUNDATION Fieldbus	XA01064P	R
FM XP Cl.I Div.1 Gr.A-D, AEx d, Zone 1,2	4 to 20 mA HART, PROFIBUS PA, FOUNDATION Fieldbus	XA01071P	T
CSA C/US IS + XP Cl.I Div.1 Gr.A-D, Zone 1,2	4 to 20 mA HART	ZD00153P	D
	PROFIBUS PA, FOUNDATION Fieldbus	ZD00191P	
ATEX II Ex ia/Ex d + FM/CSA IS + XP ATEX II 1/2G Ex ia IIC T6+ ATEX II 2G Ex d IIC T6+FM/CSA IS + XP Cl.I.II Div.1 Gr.A-G/B-GFM/CSA: Zone 1,2	4 to 20 mA HART	XA00242P ZD00153P XA01196P	F
	PROFIBUS PA, FOUNDATION Fieldbus	XA00242P XA01198P ZD00191P	
CSA C/US XP Cl.I Div.1 Gr.B-D, Ex d, Zone 1,2	4 to 20 mA HART, PROFIBUS PA, FOUNDATION Fieldbus	ZD00229P	V
CSA C/US Cl.II, III Div.1 Gr.E-G	4 to 20 mA HART, PROFIBUS PA, FOUNDATION Fieldbus	CSA1509834	W
CSA C/US General Purpose	4 to 20 mA HART, PROFIBUS PA, FOUNDATION Fieldbus	-	Z

1) Product Configurator, order code for "Approval"



[www.addresses.endress.com](http://www.addresses.endress.com)

---