

Pressure gauge for scuba diving Finimeter Models 216.06.050 and 216.40.050

WIKA data sheet PM 02.31

Applications

- Scuba diving
- Pressure measurement of breathing air or nitrox in diving equipment

Special features

- Can be used for diving depths of up to 500 m [1,640 ft]
- Compact design
- High impact resistance of the window from polycarbonate
- Scale ranges up to 0 ... 600 bar [8,700 psi], optionally in other units (e.g. MPa or kg/cm²)



Fig. left: Model 216.06.050

Fig. right: Model 216.40.050

Description

These pressure gauges meet the highest standards in terms of quality and reliability in scuba diving applications. The compact finimeter is a component of diving equipment for cylinder pressure measurement.

Due to the fine scale graduation, the pressure is very well readable. Through its long fade-out time, the phosphorescent dial also makes the readability easier in poor lighting conditions.

For the diver's safety, a window of shatterproof polycarbonate is used.

Specifications

Basic information	
Standard	
Model 216.06.050	Based on EN 250
Model 216.40.050	Based on EN 14143
Diving depth	
Model 216.06.050	≤ 100 m [328 ft]
Model 216.40.050	≤ 500 m [1,640 ft]
Nominal size (NS)	Ø 50 mm [2"]
Connection location	Lower mount (radial)
Window	Polycarbonate
Case	Brass, nickel-plated
Mounting	<ul style="list-style-type: none"> ■ Without ■ Panel mounting flange, stainless steel ■ Panel mounting flange, polished stainless steel ■ Triangular profile ring with mounting bracket, polished stainless steel ■ Surface mounting flange, stainless steel
Movement	Copper alloy

Measuring element	
Type of measuring element	Bourdon tube, helical type
Material	
Model 216.06.050	Copper alloy
Model 216.40.050	Stainless steel

Accuracy specifications	
Accuracy class	Indication accuracy per EN 250
Temperature error	On deviation from the reference conditions at the measuring system: ≤ ±0.4 % per 10 °C [≤ ±0.4 % per 18 °F] of full scale value
Reference conditions	
Ambient temperature	+20 °C [68 °F]

Scale range	
Scale range	
Model 216.06.050	Maximum 0 ... 400 bar [5,800 psi]
Model 216.40.050	Maximum 0 ... 600 bar [8,700 psi]
Dial	
Scale colour	Black
Material	Model 216.06.050 Plastic
	Model 216.40.050 Aluminium
Version	Scale phosphorescent with long fade-out time
	Other scales or customer-specific dials, e.g. with red mark, circular arcs or circular sectors, on request

Scale range		
Pointer		
Instrument pointer	Model 216.06.050	Aluminium, black
	Model 216.40.050	Copper alloy, black
Mark pointer/drag pointer	<ul style="list-style-type: none"> ■ Without ■ Red mark pointer on dial, fixed 	
Pointer stop pin	At zero point	

Other scale ranges on request

Process connection		
Standard		
Model 216.06.050	ANSI B1.1	
Model 216.40.050	EN 837-1	
Size		
ANSI B1.1	7/16-20 UNF, male thread	
EN 837-1	<ul style="list-style-type: none"> ■ G 1/8 B, male thread ■ M12 x 1.5, male thread 	
Restrictor	<ul style="list-style-type: none"> ■ Without ■ Ø 0.3 mm [0.012"], copper alloy ■ Ø 0.2 mm [0.008"], copper alloy 	
Material (wetted)		
Process connection	Copper alloy	
Bourdon tube	Model 216.06.050	Copper alloy
	Model 216.40.050	Stainless steel

Other process connections on request

Operating conditions		
Pressure limitation	Steady	3/4 x full scale value
	Fluctuating	2/3 x full scale value
	Short time	Full scale value

Dimensions in mm [in]

Model 216.06.050

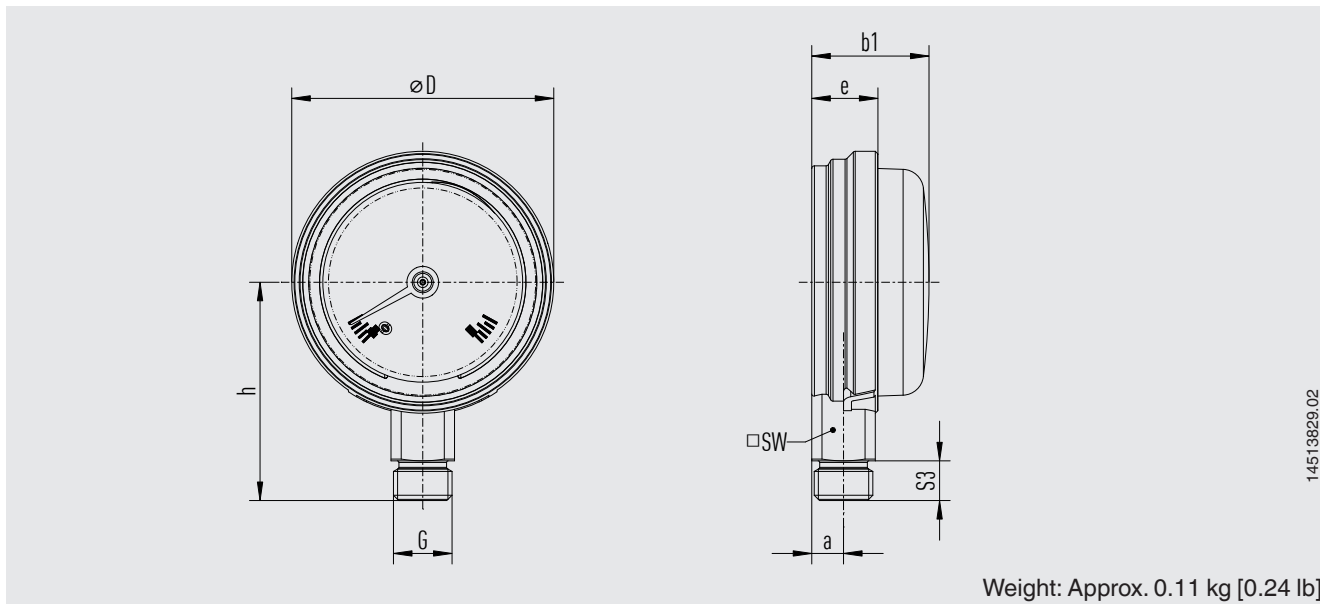

14513829.02

G	Dimensions in mm [in]						
	D	a	b1 ±0.5 [0.02]	e	h ±1 [0.04]	S3	SW
G ½ B	49.5 [1.95]	6 [0.24]	22.2 [0.87]	12.5 [0.49]	41.3 [1.62]	12.5 [0.49]	12 [0.47]
7/16-20 UNF	49.5 [1.95]	6 [0.24]	22.2 [0.87]	12.5 [0.49]	41.3 [1.62]	7.5 [0.30]	12 [0.47]

Model 216.40.050

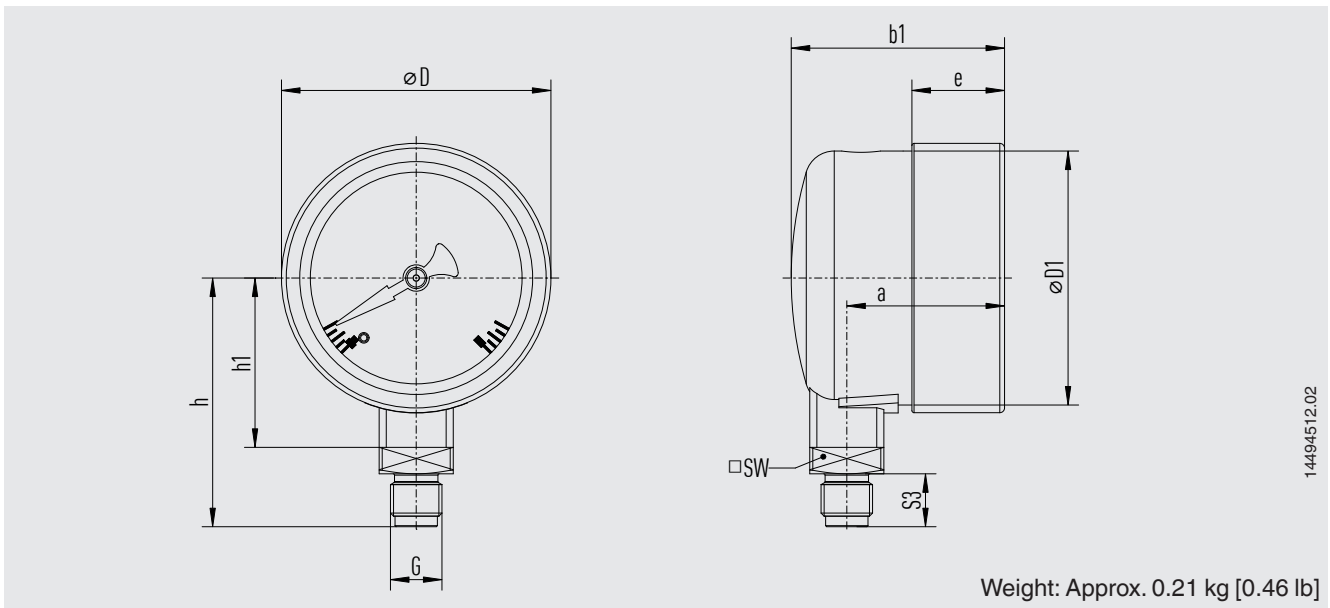

G	Dimensions in mm [in]							
	D	D1	a	b1 ±0.5 [0.02]	h ±1 [0.04]	h1 ±0.5 [0.02]	S3	SW
G ½ B	50.9 [2]	48 [1.89]	29.8 [1.17]	40.3 [1.59]	47 [1.85]	32 [1.26]	10 [0.39]	14 [0.55]
M12 x 1.5	50.9 [2]	48 [1.89]	29.8 [1.17]	40.3 [1.59]	50 [1.97]	32 [1.26]	13 [0.51]	14 [0.55]

Ordering information

Model / Scale range / Process connection / Special design feature

© 03/2018 WIKA Alexander Wiegand SE & Co. KG, all rights reserved.
 The specifications given in this document represent the state of engineering at the time of publishing.
 We reserve the right to make modifications to the specifications and materials.

