

# Air velocity meter

## Model A2G-20

WIKA data sheet SP 69.06



### Applications

- For measuring the air velocity and the temperature of air and other non-inflammable and non-aggressive gases in fresh and exhaust air ducts
- Designed for direct connection to control systems or the building automation system

### Special features

- Electrical output signal DC 0 ... 10 V or 4 ... 20 mA, can be selected directly at the instrument via jumpers
- Output signal for velocity and air temperature in one instrument
- With switching output
- Mounting flange for mounting on circular ventilation pipes or rectangular ventilation ducts
- Maintenance-free



Air velocity meter with LC display, model A2G-20

### Description

The model A2G-20 air velocity meter is used for measuring flow rates of gaseous media in ventilation and air-conditioning applications. In addition, the A2G-20 features integrated temperature measurement.

Electrical output signals for both measurands (DC 0 ... 10 V or 4 ... 20 mA; adjustable at the instrument via jumpers) enable the direct connection to control systems or the building automation system.

An additional switching output enables a flexible operation for controlling further components of a ventilation and air-conditioning system.

The LC display and the clear menu navigation enable a time-saving and simple commissioning.

# Specifications

Air velocity meter, model A2G-20	
<b>Version</b>	<ul style="list-style-type: none"> <li>■ Version without LC display</li> <li>■ Version with LC display</li> <li>■ Version with LC display and switching output</li> </ul>
<b>Measuring element</b>	Pt1000 (air velocity) and NTC10k (temperature)
<b>Measuring range</b>	
Air velocity	0 ... 2 m/s [0 ... 7 ft/s], 0 ... 10 m/s [0 ... 33 ft/s] or 0 ... 20 m/s [0 ... 66 ft/s] can be selected at the instrument via jumpers
Temperature	0 ... 50 °C [32 ... 122 °F]
<b>Accuracy</b>	
Air velocity	Measuring range 0 ... 2 m/s: < 0.2 m/s [0.3 ft/s] +5 % of reading Measuring range 0 ... 10 m/s: < 0.5 m/s [1.6 ft/s] +5 % of reading Measuring range 0 ... 20 m/s: < 1.0 m/s [3.3 ft/s] +5 % of reading
Temperature <sup>1)</sup>	< 0.5 °C [0.9 °F] (v > 0.5 m/s)
<b>Power supply U<sub>B</sub></b>	DC 24 V/AC 24 V ±10 %
<b>Output signal</b>	
Air velocity	DC 0 ... 10 V (linear to m/s): Load min. 1 kΩ 4 ... 20 mA (linear to m/s): Load max. 400 Ω
Temperature	DC 0 ... 10 V (linear to °C): Load min. 1 kΩ 4 ... 20 mA (linear to °C): Load max. 400 Ω
<b>Electrical connection</b>	Screw terminals Cable gland M16 max. 1.5 mm <sup>2</sup>
<b>Switching output</b>	3 screw terminals max. 1.5 mm <sup>2</sup> (NC, COM, NO) Relay (potential-free, change-over contact, max. AC 250 V, 6 A, DC 30 V, 6 A, adjustable switching threshold and hysteresis)
<b>Case</b>	Plastic (ABS)
<b>LC display</b>	3 ½-digit display with backlighting Size: 46.7 x 12.7 mm
<b>Permissible temperatures</b>	
Medium	0 ... 50 °C, max. 95 % r. h.
Ambient	0 ... 50 °C, max. 95 % r. h.
<b>Ingress protection per IEC/EN 60529</b>	IP54
<b>Weight</b>	220 g
<b>Mounting</b>	Duct installation by means of mounting flange

1) The unit is calibrated at 22 °C [71.6 °F].

## Electrical connection

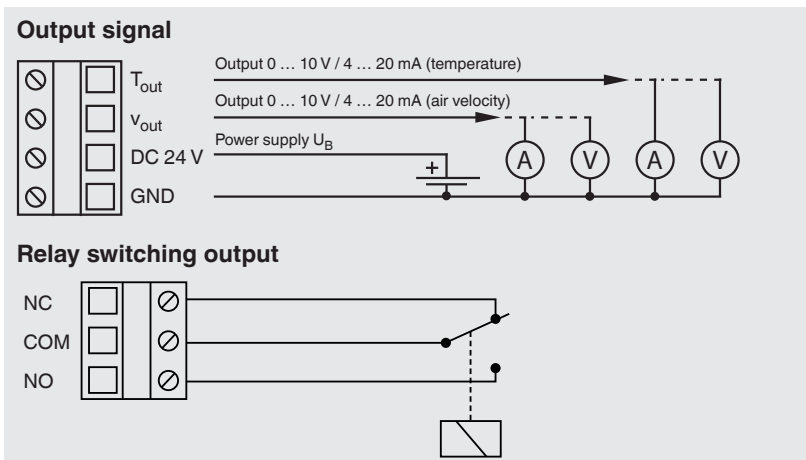

**Dimensions in mm**

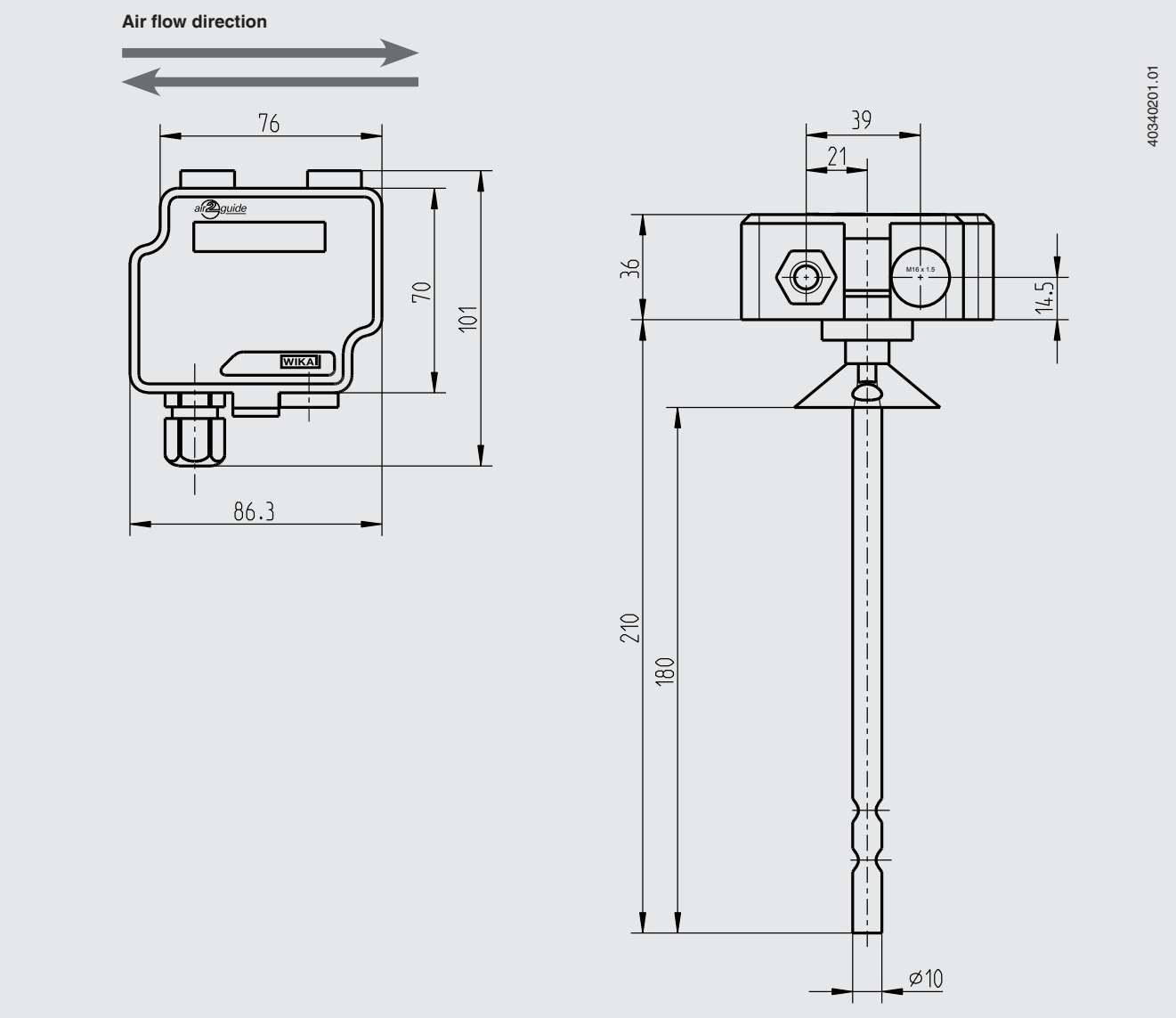

40340201.01

**Mounting flange**

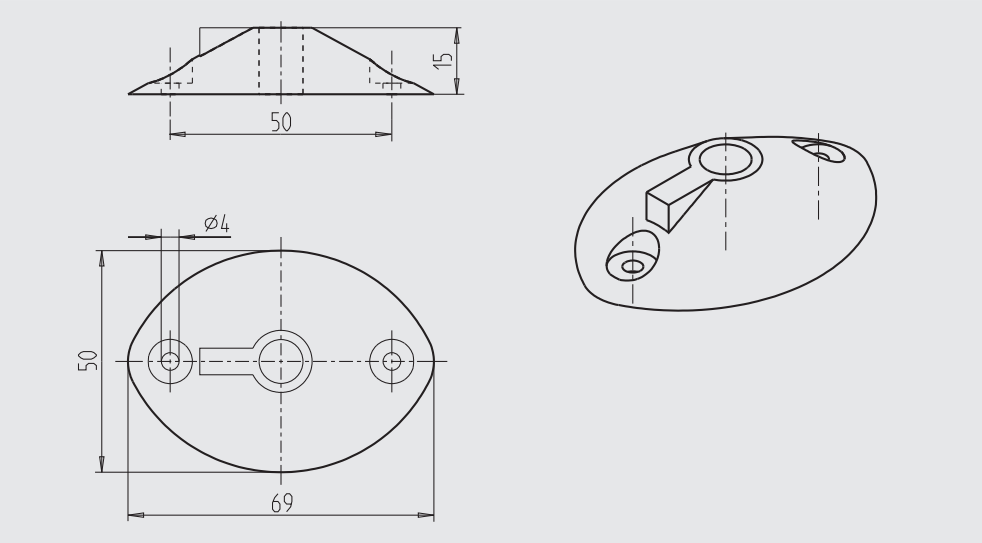

## Certificates (Option)

- 2.2 test report

### Ordering Information

Model / Version / Options

© 02/2011 WIKA Alexander Wiegand SE & Co. KG, all rights reserved.  
The specifications given in this document represent the state of engineering at the time of publishing.  
We reserve the right to make modifications to the specifications and materials.

