

Differential pressure sensor For ventilation and air-conditioning Model A2G-500

WIKA data sheet PE 88.05



Applications

- Measurement of differential pressure, gauge pressure and vacuum
- Monitoring of filters, ventilators and heat exchangers
- Pressure monitoring in ventilation ducts, laboratories, production areas and clean rooms

Special features

- IIoT-ready and future-proof thanks to analogue and digital signal transmission (Modbus®) as well as wireless (LoRaWAN®)
- Time-saving instrument configuration and display of current measured values on the smartphone via NFC or WIKA app
- No cabling effort for retrofit projects thanks to battery operation and LoRaWAN®
- Decentralised data node – up to four input signals – reduces cabling effort and installation costs
- Reduction of installation costs due to simple wall or DIN rail mounting in a control cabinet



Differential pressure sensor, model A2G-500

Description

The model A2G-500 is used to measure differential pressure, gauge pressure and vacuum in air and also in non-aggressive and non-flammable gases in ventilation and air-conditioning systems.

The piezoresistive measuring element is temperature-compensated and particularly stable over the long term. It records even the smallest pressure differences and thus ensures high reliability and the highest measurement accuracy. The measured values are available as analogue voltage and current signals, digitally via the RS-485 interface using Modbus® RTU or via LoRaWAN®. Integration into any control system or directly into cloud solutions is therefore easily possible.

With relay outputs, the instrument becomes a cost-saving differential pressure switch or 2-point controller.

The A2G-500 has freely adjustable measuring ranges. The instrument can be set using the WIKA app and NFC and, depending on the version, using buttons and LEDs or buttons and a display. Efficient project documentation is possible using instrument parameter file readout via NFC and smartphone. The indication of up to four measured values and two relay states can be read from all viewing angles thanks to 2" TFT colour display with traffic light function and individualised measurement parameter lettering.

The construction of the A2G-500 is robust and weather-proof (IP65). The case can be opened without tools thanks to the snap-on cover. The graphics of the cover sheet insert can be customised. The instruments can thus be optimally integrated into any system design.

Version

Instrument versions				
Specifications	1 x analogue output 2-wire or 3-wire (single range) ¹⁾	1 x analogue out- put 3-wire (multi range)	Modbus® RTU (multi range)	1 x wireless (battery power)
Display	x	O	O	x
Additional analogue output	x	O	O	x
Signal inputs	x	O	O	x
Relay	x	O	O	x
Automatic zero point setting	x	O	O	x
Wireless signal (LoRaWAN®)	x	O	O	✓
NFC				
Configure	✓	✓	✓	✓
Read	✓	✓	✓	✓

1) Measuring range preset

✓: included
x: not included
O: selectable

Specifications

Basic information	
Case dimensions	→ See dimensions on page 6
Process connection	2 x connecting nozzle Ø 4.5 mm [0.17 in] / Ø 7.5 mm [0.29 in] For hoses with inner diameter 4 ... 6 mm [0.157 ... 0.236 in]
Case	PC GF20
Cover with insert sheet	PC, transparent; ABS, RAL 9010
Mounting plate	PC, RAL 7035
Weight	260 ... 320 g [0,57 ... 0,70 lb] (depending on version)

Measuring ranges ¹⁾ in Pa [inWC]

Operating range ²⁾		Operating range ²⁾		Operating range ²⁾		Operating range ²⁾	
±250 Pa	±1 inWC	±2,500 Pa	±10 inWC	±7,000 Pa	±28 inWC	±12,000 Pa	±48 inWC
-25 ... +25	-0.1 ... +0.1	-500 ... +500	-2 ... +2	0 ... 1,000	0 ... 4	0 ... 5,000	0 ... 20
-50 ... +50	-0.2 ... +0.2	-1,000 ... +1,000	-4 ... +4	0 ... 1,500	0 ... 6	0 ... 6,000	0 ... 24
-100 ... +100	-0.4 ... +0.4	0 ... 250	0 ... 1	0 ... 2,000	0 ... 8	0 ... 7,000	0 ... 28
-150 ... +150	-0.6 ... +0.6	0 ... 500	0 ... 2	0 ... 2,500	0 ... 10	0 ... 7,500	0 ... 30
0 ... 25	0 ... 0.1	0 ... 1,000	0 ... 4	0 ... 3,000	0 ... 12	0 ... 8,000	0 ... 32
0 ... 50	0 ... 0.2	0 ... 1,500	0 ... 6	0 ... 4,000	0 ... 16	0 ... 9,000	0 ... 36
0 ... 100	0 ... 0.4	0 ... 2,000	0 ... 8	0 ... 5,000	0 ... 20	0 ... 10,000	0 ... 40
0 ... 250	0 ... 1	0 ... 2,500	0 ... 10	0 ... 7,000	0 ... 28	0 ... 12,000	0 ... 48

1) Settable via instrument menu (display), HMI (buttons, LEDs) or WIKA app (NFC) or preset with single-range instruments
2) Defined with model code: Selection of an operating range (with several measuring ranges) or an individual measuring range

Pressure type / Measuring element / Digital display	
Pressure type	Differential pressure
Unit	<ul style="list-style-type: none"> ■ Pa ■ kPa ■ mbar ■ mmWC ■ inWC
Max. operating pressure	<ul style="list-style-type: none"> ■ ±250 ... ±2.500 Pa [±1 ... ±10 inWC]: 10 kPa [40 inWC] ■ ±7.000 ... ±12.000 Pa [±28 ... ±48 inWC]: 100 kPa [400 inWC]
Measuring element	Piezo measuring cell
Digital display	
Display resolution	240 x 320 dpi
Type of display	2" TFT colour display
Dashboard function	Indication of up to four measured values and two relay states possible; automatic size scaling depending on the number of measured values displayed. Indicated values can be given any alphanumeric designation.
Colour configuration	Range of setting possibilities; colours definable via RGB code.
Alarm function	Definition of two limit values possible; on reaching these limit values, a colour change can be defined for each (e.g. "Warning" and "Alarm")

Accuracy specifications				
Accuracy 1)	0.50 % FS 2)			
Operating range	±250 Pa [±1 inWC]	±2,500 Pa [±10 inWC]	±7,000 Pa [±28 inWC]	±12,000 Pa [±48 inWC]
Temperature range				
Compensated 3) TC 4) offset (% FS/K)	0.015 %	0.01 %	0.008 %	0.005 %
Uncompensated 5) TC 4) offset (% FS/K)	0.025 %	0.02 %	0.02 %	0.01 %
Compensated 3) TC 4) span (% FS/K)	0.02 %	0.02 %	0.01 %	0.01 %
Uncompensated 5) TC 4) span (% FS/K)	0.03 %	0.02 %	0.02 %	0.02 %
Zero point setting	<ul style="list-style-type: none"> ■ Manually via push button on the PCB ■ "myWIKa wireless device" app ■ Automatic 6) 			

- 1) At 23 °C [73.4 °F], relative to reference measuring instrument
Output wiring: 200 Ω in series for current output, 1000 Ω in parallel for voltage output
- 2) E.g. 0.50 % of ±250 Pa = 1.25 Pa
- 3) 0 ... 50 °C [32 ... 122 °F]
- 4) Temperature coefficient
- 5) -40 ... 0 °C [-40 ... +32 °F] / >50 °C [>122 °F]
- 6) Recommended for measuring ranges ≤ 250 Pa [≤ 1 inWC]

Output and input signal		
Output signals	<ul style="list-style-type: none"> ■ 0 ... 10 V, 0 ... 5 V or 2 ... 10 V, 3-wire ■ 4 ... 20 mA, 2- or 3-wire ■ Relay ■ Modbus® ■ LoRaWAN® 	
Number of analogue outputs	<ul style="list-style-type: none"> ■ 1 x ■ 2 x 	
Load	Current output	Max. 500 Ω
	Voltage output	Typ. 1 kΩ, min. 500 Ω

Output and input signal	
Number of relays	<ul style="list-style-type: none"> ■ Without ■ 1 x (DC 24 V / 0.5 A) ■ 2 x (DC 24 V / 0.5 A)
Switching function	<ul style="list-style-type: none"> ■ NO (normally open) ■ NC (normally closed) ■ Force open, force closed
Input signal	
2 x voltage input	<ul style="list-style-type: none"> ■ DC 0 ... 10 V ■ DC 0 ... 5 V ■ DC 2 ... 10 V
2 x resistance input	<ul style="list-style-type: none"> ■ Pt1000 ■ Ni1000 ■ Ni1000-LG ■ NTC 10 kΩ (β = 3,977) ■ Binary (on/off)
Temperature range (resistance inputs)	-40 ... +120 °C [-40 ... +248 °F]

Electrical connection	
Connection type	Spring-clip terminals
Wire cross-section	Max. 1.5 mm ²
Cable specification	Use shielded cables ¹⁾
Cable connection	<ul style="list-style-type: none"> ■ Cable gland M20 x 1.5 with strain relief ■ Standard version with clamping area 4 ... 13 mm [0.15 ... 0.51 in] ■ Further sealing inserts available (see Accessories)
Reverse polarity protection	Integrated protection against reverse polarity and overvoltage resulting from wiring errors
Auxiliary power	
Supply voltage	<ul style="list-style-type: none"> ■ AC ²⁾ 24 V ±10 % / 50 Hz / 60 Hz ■ DC 24 V ±10 %
Power consumption	<ul style="list-style-type: none"> ■ 1.7 W at DC 24 V ■ 2.5 VA at AC 24 V
Electrical safety	Protection class III, safety extra-low voltage (SELV)

- 1) Instrument specifications are based on tests with shielded cables
2) Not permissible for 2-wire 4 ... 20 mA

Operating conditions	
Medium and ambient temperature range	<ul style="list-style-type: none"> ■ -40 ... +60 °C [-40 ... +140 °F] ■ -10 ... +50 °C [14 ... 122 °F], with automatic zero point setting ■ -20 ... +60 °C [-4 ... +140 °F], with display
Storage temperature range	-40 ... +60 °C [-40 ... +140 °F]
Relative humidity, condensation	0 ... 95 % relative humidity (non-condensing)
Permissible media	<ul style="list-style-type: none"> ■ Air ■ Non-aggressive gases ■ Non-flammable gases
Mounting position	
Process connections	Lower mount ¹⁾ Side mount ²⁾
Ingress protection of the complete instrument	IP65

- 1) Measurement accuracy and IP protection are based on tests with lower mount (reference position)
2) Deviation when side mount: +2 Pa; can be corrected via zero point function

NFC interface

NFC specification	
On-site interface	NFC (near field communication)
Standard	ISO/IEC 15693
Modulation	13.56 MHz

Modbus® interface

Modbus® communication	
Protocol	Modbus® via serial interface
Transfer mode	RTU
Interface	RS-485
Max. voltage	<ul style="list-style-type: none"> ■ ± 10 V without terminating resistor ■ ± 6 V with terminating resistor

LoRa® interface

LoRaWAN® specification	
LoRaWAN® specification	LoRa® 868 MHz EU
Version	1.0.3
Frequency range	863 ... 870 MHz
Transmission power	12 dBm
Range 1)	≤ 10 km [≤ 6.21 miles]
Max. output power	14 dBm

1) The range depends on the topography. 10 km [6.2 mi] can be achieved in free field conditions and with a spreading factor of 12.

Approvals

Logo	Description	Region
	EU declaration of conformity	European Union
	EMC directive	
	RED - Radio Equipment Directive	
	RoHS directive	
	WEEE directive	

Certificates

Certificates	
Certificates	<ul style="list-style-type: none"> ■ Without ■ Measurement report per EN 837 ■ 2.2 test report per EN 10204 (e.g. state-of-the-art manufacturing, material proof, indication accuracy) ■ 3.1 inspection certificate per EN 10204 (e.g. material proof for wetted metal parts, indication accuracy, calibration certificate)

→ For approvals and certificates, see website

Dimensions in mm [in]

Differential pressure sensor, model A2G-500

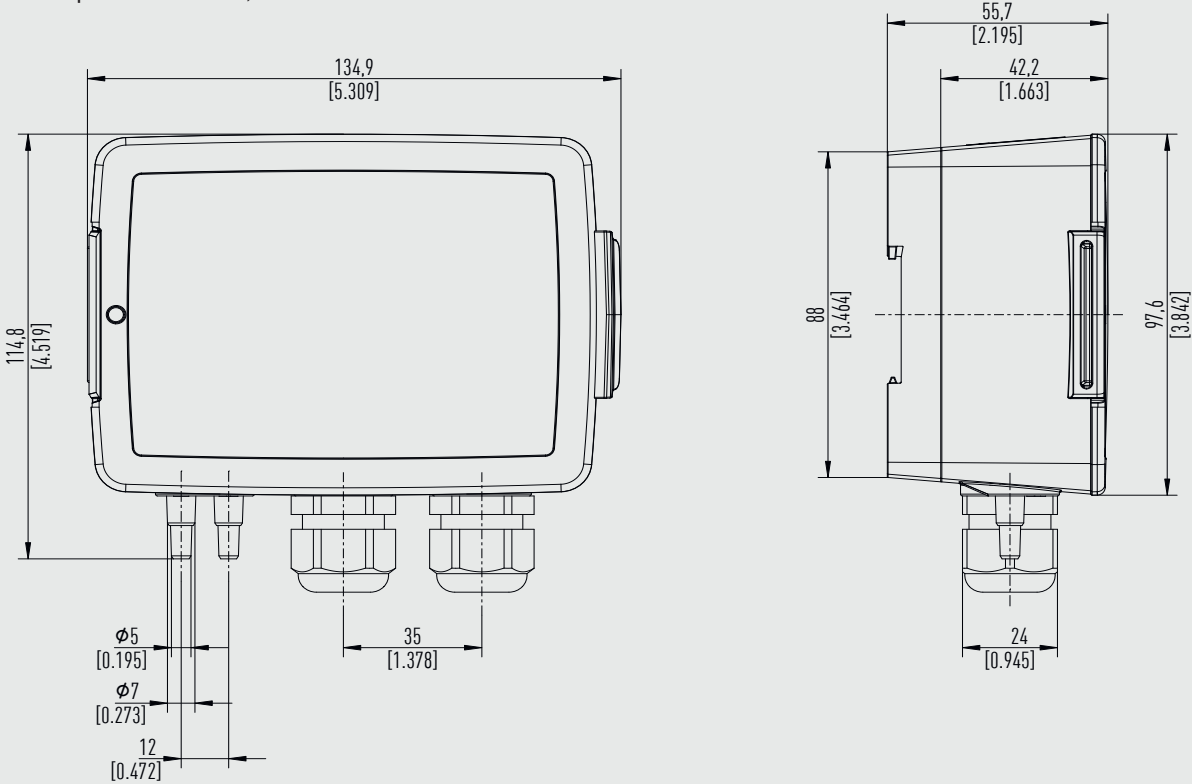

Mounting plate

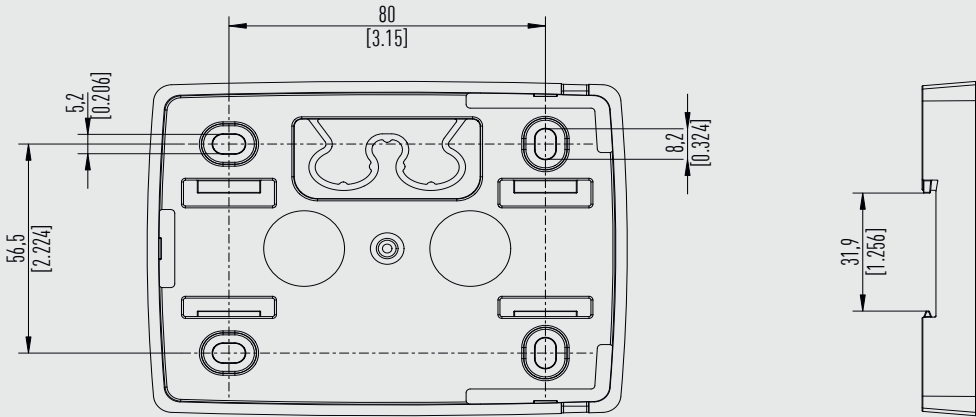

Electrical connection

Output signal 4 ... 20 mA, 2-wire

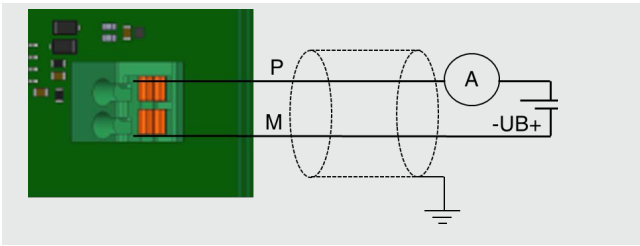

Output signal 0 ... 10 V or 0 ... 5 V or 2 ... 10 V or 4 ... 20 mA, 3-wire

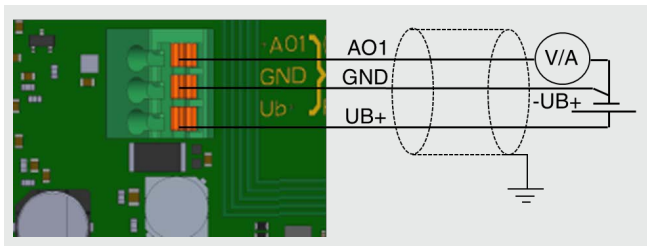

Output signal 0 ... 10 V or 0 ... 5 V or 2 ... 10 V or 4 ... 20 mA, 3-wire

With display and/or relay and/or signal input

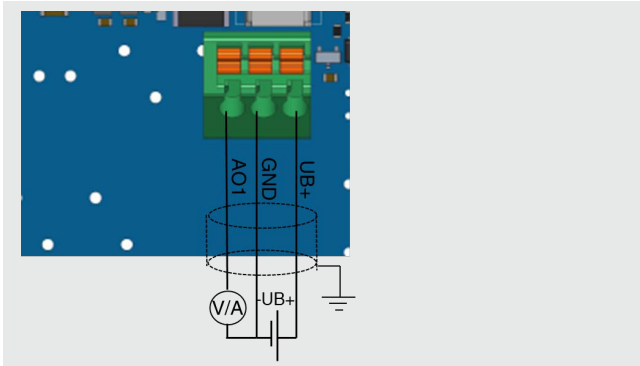

Modbus® RTU

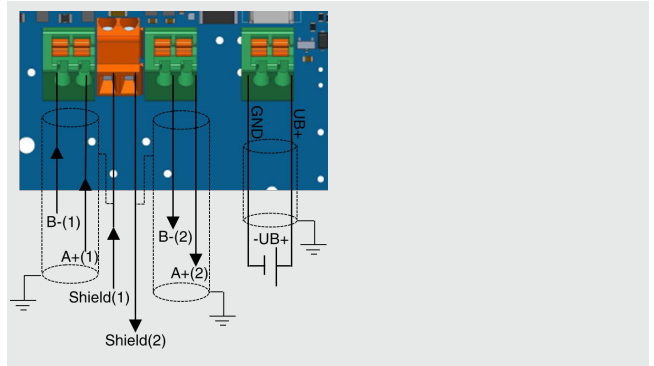

Additional electronic connection

Additional signal output

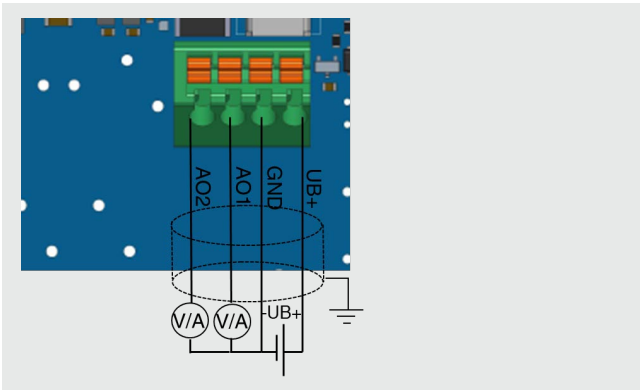

One or two relay outputs

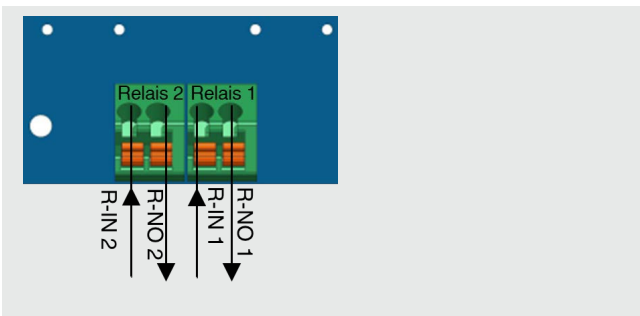





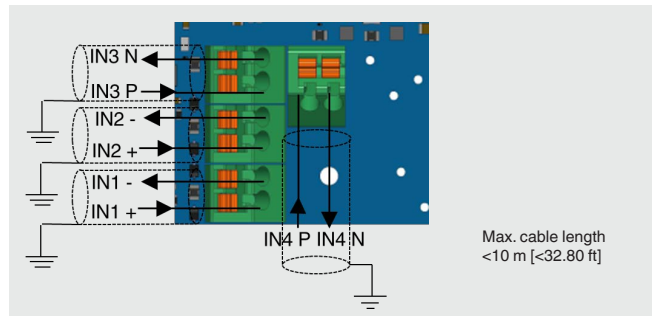

Up to four signal inputs

IN1, IN2 = active input signal

IN3, IN4 = passive input signal



Accessories 1)

Model	Description	Order number
	Measuring hoses	
	PVC hose, inner diameter 4 mm [0.16 in], roll at 25 m [82.02 ft]	40217841
	PVC hose, inner diameter 6 mm [0.24 in], roll at 25 m [82.02 ft]	40217850
	Silicone hose, inner diameter 4 mm [0.16 in], roll at 25 m [82.02 ft]	40217906
	Silicone hose, inner diameter 6 mm [0.24 in], roll at 25 m [82.02 ft]	40217914
	2 x of duct connector for measuring hoses Ø 4 ... 6 mm [0.16 ... 0.24 in] and 4 x of mounting screw	40217507
	Multiple sealing inserts (for M20 cable gland)	
	Sealing insert with 2 bores at Ø 4 mm [0.16 in]; PU 10 x	40444284
	Sealing insert with 2 bores at Ø 6 mm [0.24 in]; PU 10 x	40444285
	Sealing insert with 4 bores at Ø 5 mm [0.20 in]; PU 10 x	40444286
	Battery AA 3.6 V, 2.6 Ah (only with battery version); PU 2 x	40443947
	LoRaWAN® gateway, preconfigured for WIKA network server	On request
	Gateway for indoor use	
	Gateway for outdoor use	

1) The figures are an example and may change depending on the state of the art in design, material composition and representation.

Scope of delivery

- Differential pressure sensor model A2G-500
- Mounting plate
- 4 x pan-head, self-tapping screws ST4.2x9.5 (cross head Philipps Form H2)
- 2 x batteries AA 3.6 V, 2.6 Ah (only with battery version)

Ordering information

Model / Unit / Operating range / Measuring range / Output signal / Display / Zero point setting / 2nd analogue output / Relay / Signal input / Accessories / Certificates / Approvals

The LoRa® brand and the LoRa® logo are trademarks of Semtech Corporation.

LoRaWAN® is a trademark used under licence from LoRa-Alliance®.

Modbus® is a registered trademark of Schneider Electric.

© 10/2023 WIKA Alexander Wiegand SE & Co. KG, all rights reserved.

The specifications given in this document represent the state of engineering at the time of publishing.

We reserve the right to make modifications to the specifications and materials.

In case of a different interpretation of the translated and the English data sheet, the English wording shall prevail.