

# Submersible pressure sensor

## For general applications

### Model LS-1000

WIKA data sheet LM 40.05



#### Applications

- Sewage lifting stations
- AdBlue tanks
- Pumping stations

#### Special features

- Hydrostatic levels 1 ... 10 m [3,28 ... 32,81ft]
- Permanently leak-tight thanks to special materials and sophisticated design
- Low total cost of ownership due to the highest reliability and durability



Submersible pressure sensor, model LS-1000

#### Description

The model LS-1000 submersible pressure sensor continuously measures the level of liquid media in industrial environments. It records the level hydrostatically from 1 to 10 m. Optimum long-term stability ensures precise measured data and minimal signal drift. Hermetic leak tightness is ensured by the robust design and a specially developed cable with integrated strain relief. Due to its attractive pricing, the LS-1000 submersible pressure sensor is the ideal choice for OEM customers.

#### Permanently leak-tight thanks to sophisticated design

The fully welded probe, made of stainless steel, works reliably thanks to IP68 ingress protection. A special cable design with integrated fibre mesh ensures effective strain relief. The potting of the cable inlet provides additional safety. In addition, a helium leak test is carried out for each individual instrument in our final inspection so that even the smallest leaks and hair-line cracks can be detected.

#### Low total cost of ownership

The submersible pressure sensor is maintenance-free and especially stable over the long term with an accuracy of 0.5 percent. This minimises failures, downtimes and the total cost of ownership.

## Specifications

Accuracy specifications per IEC 62828-1	Max. measured error $\leq \pm 0.5$ % of span	Max. measured error $\leq \pm 1.0$ % of span
Non-linearity per BFSL	$\leq \pm 0.25$ % of span	$\leq \pm 0.5$ % of span
Long-term stability	$\leq \pm 0.2$ % of span/year	$\leq \pm 0.2$ % of span/year

### Further details on: Accuracy specifications

Accuracy	→ See max. measured error per IEC 62828-1, above
Total probable error per IEC 62828-2	→ See table „Total probable error per IEC 62828-2“ below
Non-repeatability per IEC 62828-1	$\leq 0.1$ % of span ( $\leq 0.2$ % of span with measuring range 100 mbar [1,45 psi])
Reference conditions	Per IEC 62828-1

Total probable error per IEC 62828-2	Max. measured error $\leq \pm 0.5$ % of span	Max. measured error $\leq \pm 1.0$ % of span
<b>Temperature range -10 ... +5 °C [+14 ... +41 °F]</b>		
Measuring range $\leq 0.1$ bar	2.0 %	2.2 %
Measuring range $\leq 0.25$ bar	1.3 %	1.6 %
Measuring range $\geq 0.4$ bar	1.0 %	1.3 %
<b>Temperature range +5 ... +35 °C [+41 ... +95 °F]</b>		
Measuring range $\leq 0.1$ bar	1.1 %	1.4 %
Measuring range $\leq 0.25$ bar	0.7 %	1.1 %
Measuring range $\geq 0.4$ bar	0.6 %	1.1 %
<b>Temperature range +35 ... +50 °C [+95 ... +122 °F]</b>		
Measuring range $\leq 0.1$ bar	2.0 %	2.2 %
Measuring range $\leq 0.25$ bar	1.3 %	1.6 %
Measuring range $\geq 0.4$ bar	1.0 %	1.3 %

### Measuring ranges, gauge pressure

bar	
0 ... 0.1	0 ... 0.4
0 ... 0.16	0 ... 0.6
0 ... 0.25	0 ... 1

psi	
0 ... 5	0 ... 15
0 ... 10	-

inWC	
0 ... 50	0 ... 250
0 ... 100	0 ... 400
0 ... 150	-

### Measuring ranges, absolute pressure

bar	
0 ... 1.25	0 ... 1.6
0 ... 1.4	0 ... 2

Further details on: Measuring range	
<b>Units</b>	<ul style="list-style-type: none"> <li>■ bar</li> <li>■ psi</li> <li>■ inWC</li> <li>■ mH<sub>2</sub>O</li> <li>■ mbar</li> <li>■ kPa</li> </ul>
<b>Max. working pressure</b>	Corresponds to the upper measuring range value/measuring range full scale value
<b>Overpressure limit per IEC 62828-1</b>	1.5 times
	The overpressure limit is based on the measuring range.

Output signal	Current (2-wire)
<b>Signal type</b>	4 ... 20 mA
<b>Load in <math>\Omega</math></b>	$\leq (\text{auxiliary power} - 8 \text{ V}) / 0.023 \text{ A} - (\text{cable length in m} \times 0.0942 \text{ } \Omega/\text{m})$
<b>Signal clamping</b>	
Min.	3.8 mA
Max.	20.5 mA
<b>Voltage supply</b>	
Auxiliary power	DC 8 ... 35 V
Current supply	Max. 25 mA
Overvoltage resistance	DC 40 V
<b>Diagnostic function</b>	
Max. permissible underpressure/overpressure	21.5 mA
Max. permissible undertemperature/overtemperature	21.5 mA
Sensor defect	3.6 mA
Sensor short-circuit	3.6 mA
EEPROM error	3.6 mA
Auxiliary power outside specification	< 3.0 mA
<b>Dynamic behaviour</b>	
Switch-on time	$\leq 50 \text{ ms}$

Electrical connection	
<b>Connection type</b>	Cable, shielded
<b>Wire cross-section</b>	0.24 mm <sup>2</sup>
<b>Cable diameter</b>	7.5 mm [0.3 in]
<b>Pin assignment</b>	See „Pin assignment“ auf Seite 4
<b>Tension force of cable</b>	800 N
<b>Cable length</b>	<ul style="list-style-type: none"> <li style="width: 50%;">■ 3 m</li> <li style="width: 50%;">■ 10 ft</li> <li style="width: 50%;">■ 5 m</li> <li style="width: 50%;">■ 20 ft</li> <li style="width: 50%;">■ 10 m</li> <li style="width: 50%;">■ 30 ft</li> <li style="width: 50%;">■ 15 m</li> <li style="width: 50%;">■ 40 ft</li> <li style="width: 50%;">■ 20 m</li> <li style="width: 50%;">■ 50 ft</li> <li style="width: 50%;">■ 25 m</li> <li style="width: 50%;">■ 75 ft</li> <li style="width: 50%;">■ 30 m</li> <li style="width: 50%;">■ 100 ft</li> </ul>
<b>Lead resistance</b>	0.0942 $\Omega/\text{m}$
<b>Short-circuit resistance</b>	S+ vs. U-
<b>Reverse polarity protection</b>	U+ vs. U-

Electrical connection	
Insulation voltage	DC 750 V
Material	<ul style="list-style-type: none"> <li>■ PVC</li> <li>■ FEP</li> </ul>

Other cable lengths on request.

### Pin assignment

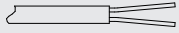
Cable outlet, shielded			
		2-wire	3-wire
	U+	Brown	Brown
	U-	Blue	Blue
	S+	-	Black
	Shield	Grey	Grey

### Legend

- U+ Positive power supply terminal
- U- Negative power supply terminal
- S+ Analogue output

Material	
<b>Material (wetted)</b>	
Case	Stainless steel 316L
Sensor element	Stainless steel 316L
Cable	<ul style="list-style-type: none"> <li>■ PVC</li> <li>■ FEP</li> </ul>
Sealing	Epoxy resin
Protective cap	PVDF
<b>Material (in contact with the environment)</b>	
Measuring location marking	PE (polyethylene)

Operating conditions	
Medium temperature limit	-10 ... +50 °C [+14 ... +122 °F]
Ambient temperature limit	-30 ... +80 °C [-22 ... +176 °F]
Storage temperature limit	-40 ... +80 °C [-40 ... +176 °F]
Pollution degree	2
Vibration resistance per IEC 60068-2-6	4g (25 - 100 Hz)
Shock resistance per IEC 60068-2-6	10g (6 ms)
<b>Free fall per IEC 60068-2-31</b>	
Without packaging	1 m [3.28 ft]
With individual packaging	0.5 m [4.64 ft]
<b>Mounting position</b>	Calibrated in vertical mounting position with process connection facing downwards.
<b>Ingress protection (IP code) per IEC 60529</b>	IP68 (permanently, max. 15 m [49,2 ft])
<b>Service life</b>	10 million load cycles
<b>Weight</b>	
Submersible pressure sensor	Max. 200 g [0.441 lb]
Cable	<ul style="list-style-type: none"> <li>■ PVC approx. 75 g/m [2.64 lb/ft]</li> <li>■ FEP approx. 90 g/m [3.17 lb/ft]</li> </ul>

Packaging and instrument labelling	
Packaging	Individual packaging
Instrument labelling	<ul style="list-style-type: none"> <li>■ WIKA product label, lasered (including Measuring location marking with product label)</li> <li>■ Customer-specific product label on request</li> </ul>

## Approvals

Logo	Description	Region
CE	<b>EU declaration of conformity</b>	European Union
	EMC directive	
	EN 61326 emission (group 1, class B) and immunity (industrial environments)	
	Pressure Equipment Directive	
	RoHS directive	

## Manufacturer's information and certificates

Logo	Description
-	China RoHS directive

## Certificates (option)



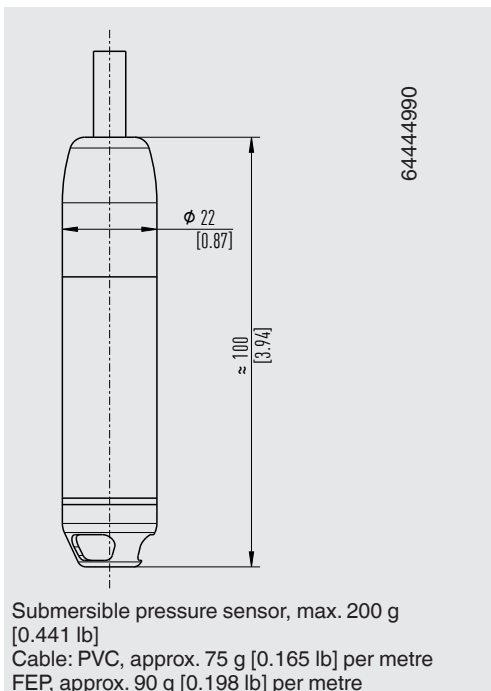

Certificates	
Certificates	<ul style="list-style-type: none"> <li>■ 2.2 test report per EN 10204 (e.g. state-of-the-art manufacturing, material proof, indication accuracy)</li> </ul>

→ For approvals and certificates, see website

## Dimensions in mm [in]



## Accessories and spare parts

Model	Description	Order number
	<p><b>Additional weight</b></p> <p>The additional weight increases the dead weight of the submersible pressure sensor. It simplifies the lowering in monitoring wells, narrow shafts and deep wells. It effectively reduces negative environmental influences of the medium (e.g. turbulent flows) on the measuring result.</p> <p>Stainless steel 316L, approx. 300 g [0.661 lb], length 115 mm [4.53 in]</p>	14131008
	<p><b>Cable strain relief clamp</b></p> <p>The cable strain relief clamp ensures easy and secure mechanical fastening of the submersible pressure sensor's cable. It serves to guide the cable to prevent mechanical damage and to reduce the action of tensile stresses.</p>	14052336
	<p><b>Cable socket</b></p> <p>The cable socket, with IP67 ingress protection and waterproof ventilation element, provides a moisture-free electrical termination for the submersible pressure sensor. It should be mounted in a dry environment, outside any shafts or vessels, or directly in the control cabinet.</p> <p>Not suitable for hazardous areas!</p>	14052339
	<p><b>Filter element</b></p> <p>The filter element prevents dirt and moisture from entering the capillary tube. The waterproof diaphragm also offers a reliable protection for the submersible pressure sensor in the harshest environments.</p>	14052344

© 06/2023 WIKA Alexander Wiegand SE & Co. KG, all rights reserved.  
 The specifications given in this document represent the state of engineering at the time of publishing.  
 We reserve the right to make modifications to the specifications and materials.  
 In case of a different interpretation of the translated and the English data sheet, the English wording shall prevail.