

Pressure transmitter

For heating and refrigeration

Model R-1

WIKA data sheet PE 81.45



For further approvals,
see page 6

Applications

- Refrigeration plants
- Heat pumps
- Air-conditioning systems

Special features

- Durable and maintenance-free
- Stable measurement in variable conditions
- Best possible condensation tightness
- Safe handling of flammable refrigerants
- Greatest possible delivery reliability with WIKA as an experienced OEM partner



Pressure transmitter, model R-1

Description

Durable and maintenance-free

The sensor has been tried and tested in the field for years and is extremely reliable. Up to 10 million load cycles are no problem for the model R-1. The model R-1 has been designed without elastomer seal, the high-accuracy measuring cell is welded directly to the process connection. All parts that come into contact with the substances in the refrigerant circuit are made of robust stainless steel with a high load capacity.

Stable measurement in variable conditions

Due to its robust design, ambient temperatures of $-25 \dots +85 \text{ °C}$ [$-13 \dots +185 \text{ °F}$] represent no problem for the model R-1. Even if the sensor temporarily freezes over, the accuracy is not limited.

Best possible condensation tightness

To simulate its harsh operating conditions, the model R-1 is tested in continuous operation with a cooler medium (-11 °C [12.2 °F]) for 500 h in a climatic chamber at 45 °C [113 °F]

and 85 % air humidity. This quality benchmark proves the sensor's high resistance to condensation and ensures long-term process reliability under extreme conditions.

Safe handling of flammable refrigerants

Thanks to a technical update to the electronics, the R-1 can now also be used in applications with flammable refrigerants.

Greatest possible delivery reliability

The model R-1 is manufactured on five production lines with a high degree of automation. The highest quality is ensured by extensive quality tests that go beyond the industry standard. For example, a 100 % end-of-line test is standard at WIKA. As a strong partner in the OEM business, WIKA offers private labelling for the model R-1.

Specifications

Accuracy specifications	
Non-linearity per BFSL per IEC 61298-2	≤ ±0.5 % of span
Accuracy	→ See "Max. measured error per IEC 61298-2"
Max. measured error per IEC 61298-2	≤ ±2 % of span
Temperature error at -25 ... +85 °C [-13 ... +185 °F]	
Mean temperature coefficient of zero point	Typical: ≤ 0.5 % of span/10 K
Mean temperature coefficient of span	≤ ±0.3 % of span/10 K
Long-term drift per IEC 61298-2	≤ ±0.3 % of span
Reference conditions	Per IEC 61298-1

Measuring ranges, gauge pressure

bar	
0 ... 6	0 ... 35
0 ... 10	0 ... 40
0 ... 15	0 ... 45
0 ... 16	0 ... 50
0 ... 20	0 ... 60
0 ... 25	0 ... 100
0 ... 30	0 ... 160

psi	
0 ... 100	0 ... 550
0 ... 150	0 ... 600
0 ... 200	0 ... 650
0 ... 250	0 ... 700
0 ... 300	0 ... 750
0 ... 350	0 ... 800
0 ... 400	0 ... 850
0 ... 450	0 ... 1,500
0 ... 500	0 ... 2,400

Vacuum and compound measuring ranges

bar	
-1 ... +7	-1 ... +25
-1 ... +9	-1 ... +29
-1 ... +10	-1 ... +45
-1 ... +15	-0.5 ... +7
-1 ... +20	-0.5 ... +10

psi	
-30 inHg ... +100	-30 inHg ... +400
-30 inHg ... +145	-30 inHg ... +450
-30 inHg ... +200	-30 inHg ... +500
-30 inHg ... +250	-30 inHg ... +550
-30 inHg ... +300	-30 inHg ... +600
-30 inHg ... +350	-

Other measuring ranges on request.

Further details on: measuring range	
Units	<input type="checkbox"/> bar <input type="checkbox"/> psi
Maximum working pressure	→ Corresponds to the upper measuring range value / measuring range full scale value → Any permanent operation above the maximum working pressure is not permissible
Overpressure limit	The overpressure limit is based on the measuring range. Depending on the selected process connection and the seal, restrictions in overpressure limit can result. 2 times → For more details, see table "Process connection"
Vacuum resistance	Yes

Process connection			
Standard	Thread size	Max. measuring range	Overpressure limit
EN 837	G ¼ B	160 bar [2,400 psi]	2 times
ANSI/ASME B1.20.1	½ NPT	160 bar [2,400 psi]	
	¼ NPT	160 bar [2,400 psi]	
ISO 7	R ¼	160 bar [2,400 psi]	
KS	PT ¼	160 bar [2,400 psi]	
SAE J513 compatible	7/16-20 UNF-2A 90°	160 bar [2,400 psi]	2 times, max. 80 bar
-	7/16-20 UNF-2B Schrader connection	60 bar [850 psi]	
-	Stainless steel blowpipe	50 bar [700 psi]	
	Stainless steel blowpipe, copper-plated		

Details must be tested separately in the respective application. The specified values for the overpressure limit serve only as a rough orientation. The values depend on the temperature, the seal used, the selected torque, the type and material of the mating thread and the prevailing operating conditions.

Further details on: process connection	
Max. measuring range	→ See table "Process connection"
Overpressure limit	→ See table "Process connection"
Pressure port diameter	3.5 mm (not with Schrader connection and blowpipe version)

Other process connections on request.

Output signal		
Signal type		
Current (2-wire)	4 ... 20 mA	
Voltage (3-wire)	■ DC 0 ... 10 V	
	■ DC 1 ... 5 V	
Ratiometric (3-wire)	DC 0.5 ... 4.5 V	
Load Ω		
Current (2-wire)	≤ (auxiliary power - 7 V) / 0.02 A	
Voltage (3-wire)	> max. output signal in V / 0.001 A	
Ratiometric (3-wire)	> max. output signal in V / 0.001 A	
Voltage supply		
Auxiliary power	Output signal 4 ... 20 mA	DC 7 ... 30 V
	Output signal DC 1 ... 5 V	DC 8 ... 30 V
	Output signal DC 0 ... 10 V	DC 14 ... 30 V
	Output signal DC 0.5 ... 4.5 V	DC 4.5 ... 5.5 V
Current supply		
Current (2-wire)	Signal current, max. 25 mA	
Voltage (3-wire)	5 mA	
Ratiometric (3-wire)	5 mA	
Overvoltage resistance	Max. DC 36 V	
Dynamic behaviour		
Settling time per IEC 61298-2	≤ 5 ms	

Other output signals on request.

Electrical connection		
Connection type	<ul style="list-style-type: none"> ■ Circular connector M12 x 1 ■ Metri-Pack series 150 ■ Cable outlet 	
Cable outlet		
Wire cross-section	3 x 0.14 mm ²	
Cable diameter	3.2 mm	
Cable length	<ul style="list-style-type: none"> ■ 0.5 m [1.64 ft] ■ 1 m [3.28 ft] ■ 2 m [6.56 ft] ■ 5 m [16.4 ft] 	
Pin assignment	→ See below	
Ingress protection (IP code) per IEC 60529 ¹⁾	Plug connection	IP67
	Cable outlet	IP69K
Short-circuit resistance	S ₊ vs. U ₋	
Reverse polarity protection	U ₊ vs. U ₋	
Insulation voltage	DC 500 V	

1) The stated IP codes only apply when plugged in using mating connectors that have the appropriate IP code.

Pin assignment

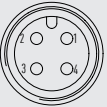
Circular connector M12 x 1 (4-pin)			
		2-wire	3-wire
	U ₊	1	1
	U ₋	3	3
	S ₊	-	4

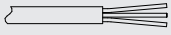
Cable outlet			
		2-wire	3-wire
	U ₊	Brown	Brown
	U ₋	Green	Green
	S ₊	-	White

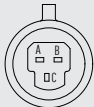
Metri-Pack series 150			
		2-wire	3-wire
	U ₊	B	B
	U ₋	C	A
	S ₊	-	C

Legend

- U₊ Positive power supply terminal
- U₋ Negative power supply terminal
- S₊ Analogue output



Material	
Material (wetted)	
Sensor and process connection	Stainless steel
Blowpipe	<ul style="list-style-type: none"> ■ Stainless steel ■ Stainless steel, copper coating
Material (in contact with the environment)	
Case	Stainless steel
Cable	PVC
Electrical connection	Highly resistant glass-fibre reinforced plastic (PBT GF30)

Operating conditions	
Medium temperature limit	-40 ... +100 °C [-40 ... +212 °F]
Ambient temperature limit	-25 ... +85 °C [-13 ... +185 °F]
Storage temperature limit	-25 ... +85 °C [-13 ... +185 °F]
Humidity	0 ... 93 % relative humidity
Operating altitude	≤ 2,000 m [≤ 6,561 ft]
Pollution degree	2
Overvoltage category	I
Service life	10 million load cycles
Free fall per IEC 60068-2-31	
Multiple packaging	0.5 m [1.6 ft]
Ingress protection (IP code) per IEC 60529	→ See table "Electrical connection"



Options for special media	
Refrigeration	Flammable refrigerants

Packaging and instrument labelling	
Packaging	Multiple packaging, 50 pieces
	Multiple packaging, 25 pieces (with cable lengths > 5 m [> 3.2 ft])
Instrument labelling	<ul style="list-style-type: none"> ■ WIKA product label, lasered ■ Customer-specific product label on request

Approvals

Logo	Description	Region
	EU declaration of conformity	European Union
	EMC Directive EN 61326 emission (group 1, class B) and immunity (industrial environments)	
	Pressure Equipment Directive	
	RoHS directive	
	EAC Electromagnetic compatibility	Eurasian Economic Community

Optional approvals

Logo	Description	Region
	UL Safety (e.g. electr. safety, overpressure, ...)	USA and Canada
	UL Component approval	USA and Canada
	UkrSEPRO Metrology, measurement technology	Ukraine
	CRN Safety (e.g. electr. safety, overpressure, ...)	Canada

Manufacturer's declarations

Logo	Description
-	China RoHS directive
MTTF	> 100 years

→ For approvals and certificates, see website

Dimensions in mm [in]

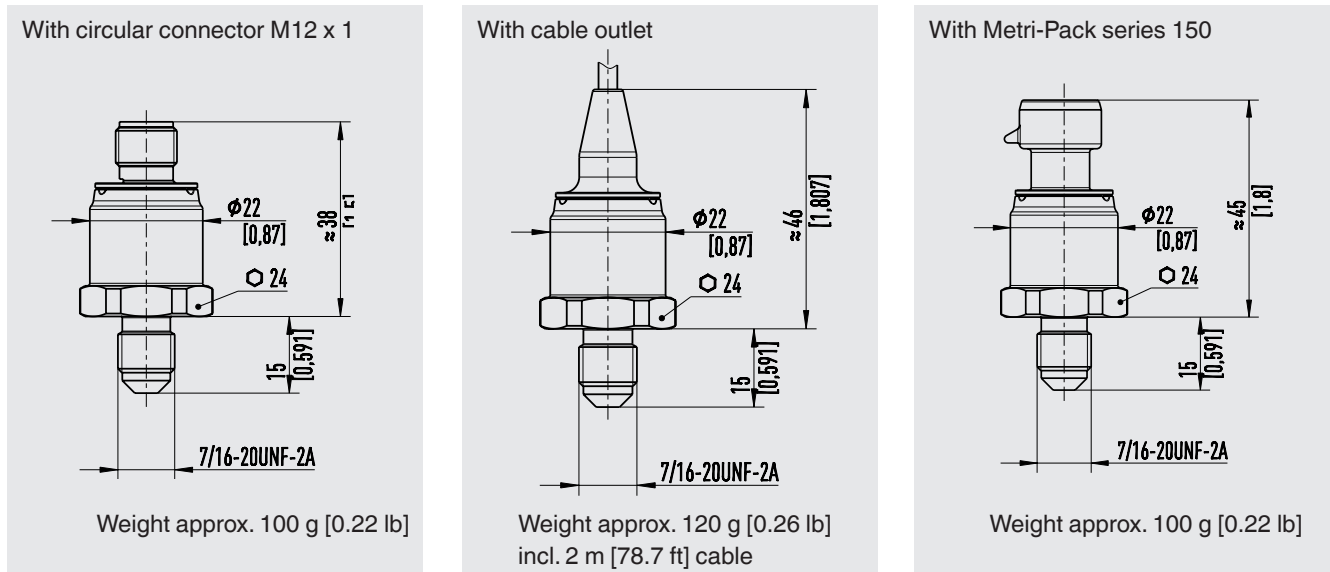

Process connections

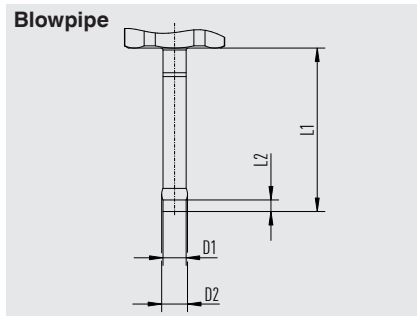

L1	L2	D1	D2
40 mm [1.57 in]	13 mm [0.51 in]	6 mm [0.24 in]	6.7 mm [0.264 in]

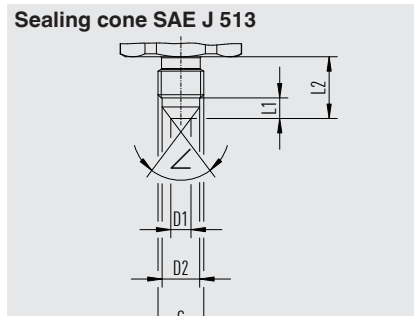

G	L1	L2	D1	D2
7/16 UNF-2A	4 mm [0.15 in]	13 mm [0.51 in]	5.6 mm [0.22 in]	8.7 mm [0.343 in]

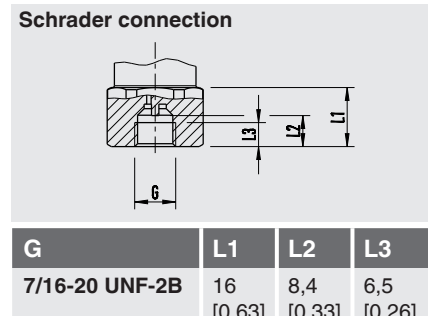

L1	L2	D1	D2	ASL
40 mm [1.57 in]	13 mm [0.51 in]	6 mm [0.24 in]	6.7 mm [0.264 in]	90° 304
				90° 316
				74° 312

→ For further process connections, see technical information IN 00.14.

Ordering information

Model / Measuring range / Output signal / Electrical connection / Process connection / Options for specific media

© 2009 WIKA Alexander Wiegand SE & Co. KG, all rights reserved.
 The specifications given in this document represent the state of engineering at the time of publishing.
 We reserve the right to make modifications to the specifications and materials.
 In case of a different interpretation of the translated and the English data sheet, the English wording shall prevail.

