

Technical Information

Proline Promag 10E

Electromagnetic flowmeter



The economical flowmeter with a highly cost-effective transmitter

Application

- The measuring principle is virtually independent of pressure, density, temperature and viscosity
- Fully suitable for basic applications in the chemical and process industry

Device properties

- Nominal diameter: max. DN 600 (24")
- All common process connections
- Liner made of PTFE
- 2-line display with push buttons
- Device in compact or remote version
- HART

Your benefits

- Cost-effective sensor – ideal solution for basic requirements
- Energy-saving flow measurement – no pressure loss due to cross-section constriction
- Maintenance-free – no moving parts
- Cost-effective – designed for easy applications and direct integration
- Safe operation – display provides easy readable process information
- Fully industry compliant – IEC/EN/NAMUR

Table of contents

Function and system design	3	Mechanical construction	18
Measuring principle	3	Design, dimensions	18
Measuring system	3	Weight	30
Input	3	Measuring tube specifications	31
Measured variable	3	Material	32
Measuring ranges	3	Fitted electrodes	32
Operable flow range	3	Process connections	32
Output	4	Surface roughness	32
Output signal	4	Operability	32
Signal on alarm	4	Local operation	32
Load	4	Remote operation	32
Low flow cutoff	4	Certificates and approvals	33
Galvanic isolation	4	CE mark	33
Power supply	4	C-tick symbol	33
Terminal assignment	4	Ex approval	33
Supply voltage	4	Other standards and guidelines	33
Power consumption	4	Pressure measuring device approval	33
Power supply failure	4	Ordering information	34
Electrical connection, measuring unit	5	Accessories	34
Electrical connection, remote version	5	Documentation	34
Potential equalization	5	Registered trademarks	34
Cable entries	7	35
Cable specifications, remote version	7		
Performance characteristics	8		
Reference operating conditions	8		
Maximum measured error	8		
Repeatability	8		
Installation	9		
Mounting location	9		
Orientation	10		
Inlet and outlet run	11		
Adapters	11		
Length of connecting cable	12		
Environment	13		
Ambient temperature range	13		
Storage temperature	13		
Degree of protection	13		
Shock and vibration resistance	13		
Electromagnetic compatibility (EMC)	13		
Process	14		
Medium temperature range	14		
Conductivity	14		
Pressure-temperature ratings	14		
Medium pressure range (nominal pressure)	15		
Pressure tightness	16		
Limiting flow	16		
Pressure loss	17		
Vibrations	17		

Function and system design

Measuring principle

Following *Faraday's law of magnetic induction*, a voltage is induced in a conductor moving through a magnetic field.

In the electromagnetic measuring principle, the flowing medium is the moving conductor. The voltage induced is proportional to the flow velocity and is supplied to the amplifier by means of two measuring electrodes. The flow volume is calculated by means of the pipe cross-sectional area. The DC magnetic field is created through a switched direct current of alternating polarity.

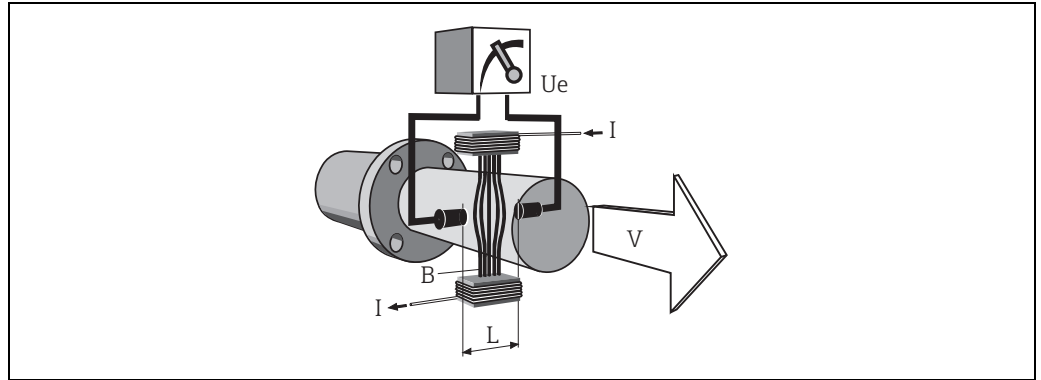

$$U_e = B \cdot L \cdot v$$

$$Q = A \cdot v$$

U_e	Induced voltage
B	Magnetic induction (magnetic field)
L	Electrode spacing
v	Flow velocity
Q	Volume flow
A	Pipe cross-section
I	Current strength

Measuring system

The measuring system consists of a transmitter and a sensor.

Two versions are available:

- Compact version: Transmitter and sensor form a mechanical unit.
- Remote version: Sensor is mounted separate from the transmitter.

Transmitter:

- Promag 10 (key operation, two-line, unilluminated display)

Sensor:

- Promag E (DN 15 to 600 / ½ to 24")

Input

Measured variable

Flow velocity (proportional to induced voltage)

Measuring ranges

Measuring ranges for liquids
Typically $v = 0.01$ to 10 m/s (0.03 to 33 ft/s) with the specified accuracy

Operable flow range

Over 1000 : 1

Output

Output signal	<p>Current output</p> <ul style="list-style-type: none"> ▪ Galvanically isolated ▪ Active: 4 to 20 mA, $R_L < 700 \Omega$ (for HART: $R_L \geq 250 \Omega$) ▪ Full scale value adjustable ▪ Temperature coefficient: typ. $2 \mu\text{A}/^\circ\text{C}$, resolution: $1.5 \mu\text{A}$ <p>Pulse/status output</p> <ul style="list-style-type: none"> ▪ Galvanically isolated ▪ Passive: 30 V DC/250 mA ▪ Open collector ▪ Can be configured as: <ul style="list-style-type: none"> – Pulse output: Pulse value and pulse polarity can be selected, max. pulse width adjustable (5 to 2000 ms), pulse frequency max. 100 Hz – Status output: for example, can be configured for error messages, empty pipe detection, flow recognition, limit value
Signal on alarm	<ul style="list-style-type: none"> ▪ Current output → Failsafe mode can be selected ▪ Pulse output → Failsafe mode can be selected ▪ Status output → "Not conductive" in the event of fault or power supply failure
Load	See "output signal"
Low flow cutoff	Switch-on points for low flow are selectable.
Galvanic isolation	All circuits for inputs, outputs and power supply are galvanically isolated from each other

Power supply

Terminal assignment	Terminal No.					
	Order code for "Input / Output"	24 (+)	25 (-)	26 (+)	27 (-)	1 (L1/L+) 2 (N/L-)
	A	Pulse/status output		HART current output		Power supply
Functional values	→  4, Section "output signal"				→ Section "Supply voltage"	

Supply voltage	<ul style="list-style-type: none"> ▪ 85 to 250 V AC, 45 to 65 Hz ▪ 20 to 28 V AC, 45 to 65 Hz ▪ 11 to 40 V DC
Power consumption	<ul style="list-style-type: none"> ▪ 85 to 250 V AC: < 12 VA (incl. sensor) ▪ 20 to 28 V AC: < 8 VA (incl. sensor) ▪ 11 to 40 V DC: < 6 W (incl. sensor) <p>Switch-on current:</p> <ul style="list-style-type: none"> ▪ Max. 3.3 A (< 5 ms) for 24 V DC ▪ Max. 5.5 A (< 5 ms) for 28 V AC ▪ Max. 16 A (< 5 ms) for 250 V AC
Power supply failure	Lasting min. ½ cycle frequency: EEPROM saves measuring system data

Electrical connection, measuring unit

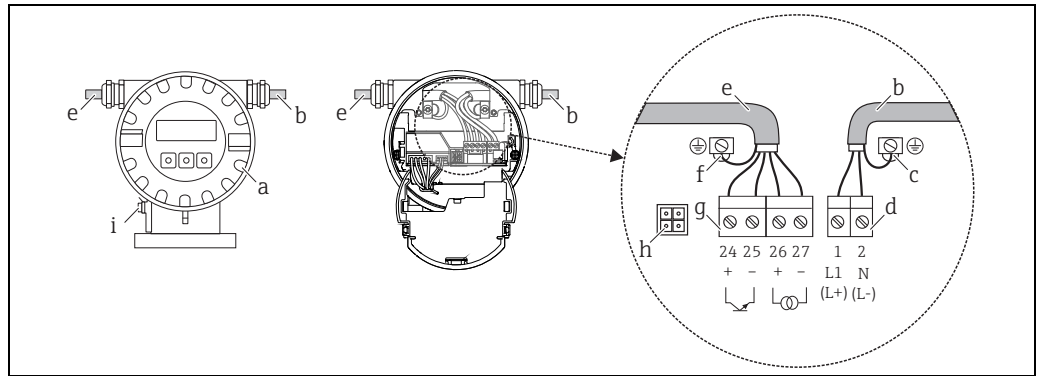

Connecting the transmitter (aluminum field housing), cable cross-section max. 2.5 mm² (14 AWG)

- a Electronics compartment cover
- b Power supply cable
- c Ground terminal for power supply cable
- d Terminal connector for power supply cable
- e Electrode cable
- f Ground terminal for electrode cable
- g Terminal connector for electrode cable
- h Service connector for connecting service interface FXA 193 (Fieldcheck, FieldCare)
- i Ground terminal for potential equalization

Electrical connection, remote version

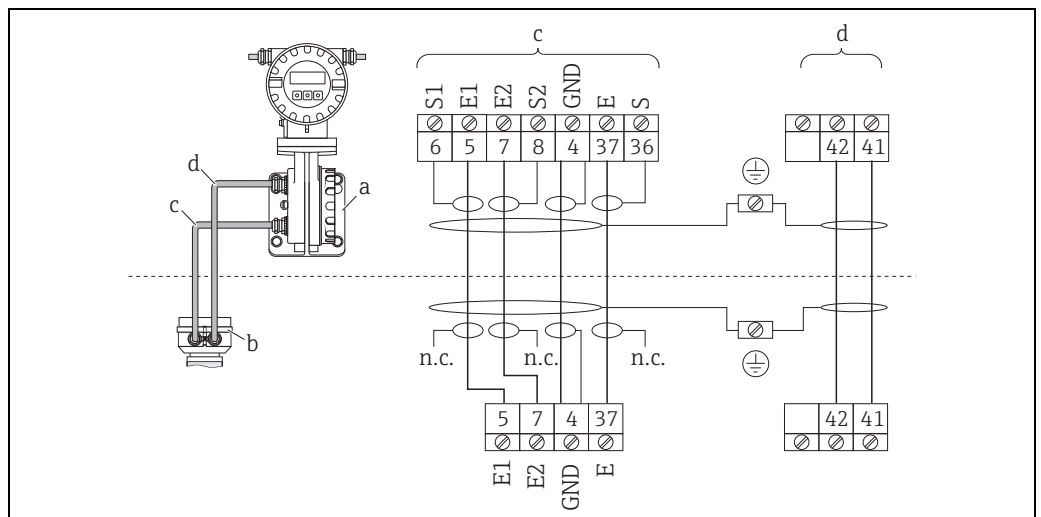

Connecting the remote version

- a Wall-mount housing connection compartment
- b Sensor connection housing cover
- c Electrode cable
- d Coil current cable
- n.c. Not connected, insulated cable shields

Terminal numbers and cable colors:
5/6 = brown, 7/8 = white, 4 = green, 37/36 = yellow

Potential equalization



Note!

The measuring system must be included in the potential equalization.

Perfect measurement is only ensured when the fluid and the sensor have the same electrical potential. This is ensured by the reference electrode integrated in the sensor as standard.

The following should also be taken into consideration for potential equalization:

- Internal grounding concepts in the company
- Operating conditions, such as the material/ grounding of the pipes (see table)

Standard situation

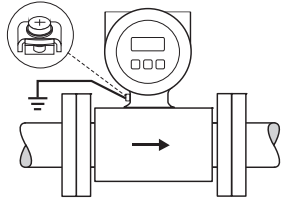
Operating conditions	Potential equalization
<p>When using the measuring device in a:</p> <ul style="list-style-type: none"> ■ Metal, grounded pipe <p>Potential equalization takes place via the ground terminal of the transmitter.</p> <p> Note! When installing in metal pipes, we recommend you connect the ground terminal of the transmitter housing with the piping.</p>	 <p style="text-align: right;">A0010831</p> <p>Via the ground terminal of the transmitter</p>

Special situations

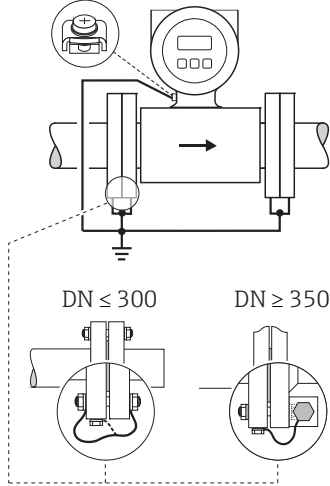
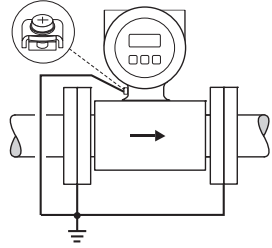
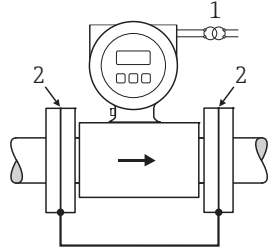
Operating conditions	Potential equalization
<p>When using the measuring device in a:</p> <ul style="list-style-type: none"> ■ Metal pipe that is not grounded <p>This connection method also applies in situations where:</p> <ul style="list-style-type: none"> ■ Customary potential equalization cannot be ensured. ■ Excessively high equalizing currents can be expected. <p>Both sensor flanges are connected to the pipe flange by means of a ground cable (copper wire, at least 6 mm² / 0.0093 in²) and grounded. Connect the transmitter or sensor connection housing, as applicable, to ground potential by means of the ground terminal provided for the purpose.</p> <ul style="list-style-type: none"> ■ DN ≤ 300 (12"): the ground cable is mounted directly on the conductive flange coating with the flange screws. ■ DN ≥ 350 (14"): the ground cable is mounted directly on the transportation metal support. <p> Note! The ground cable for flange-to-flange connections can be ordered separately as an accessory from Endress+Hauser.</p>	 <p style="text-align: right;">A0010832</p> <p>Via the ground terminal of the transmitter and the flanges of the pipe</p>
<p>When using the measuring device in a:</p> <ul style="list-style-type: none"> ■ Plastic pipe ■ Pipe with insulating lining <p>This connection method also applies in situations where:</p> <ul style="list-style-type: none"> ■ Customary potential equalization cannot be ensured. ■ Excessively high equalizing currents can be expected. <p>Potential equalization takes place using additional ground disks, which are connected to the ground terminal via a ground cable (copper wire, at least 6 mm² / 0.0093 in²). When installing the ground disks, please comply with the enclosed Installation Instructions.</p>	 <p style="text-align: right;">A0010833</p> <p>Via the ground terminal of the transmitter and the optionally available ground disks</p>
<p>When using the measuring device in a:</p> <ul style="list-style-type: none"> ■ Pipe with a cathodic protection unit <p>The device is installed potential-free in the pipe. Only the two flanges of the pipe are connected with a ground cable (copper wire, at least 6 mm² / 0.0093 in²). Here, the ground cable is mounted directly on the conductive flange coating with flange screws.</p> <p>Note the following when installing:</p> <ul style="list-style-type: none"> ■ The applicable regulations regarding potential-free installation must be observed. ■ There should be no electrically conductive connection between the pipe and the device. ■ The mounting material must withstand the applicable torques. 	 <p style="text-align: right;">A0010834</p> <p>Potential equalization and cathodic protection</p> <p>1 Power supply isolation transformer 2 Electrically isolated</p>

Cable entries

- Power supply and electrode cables (inputs/ outputs):
- Cable entry M20 × 1.5 (8 to 12 mm / 0.31 to 0.47")
 - Thread for cable entries, ½" NPT, G ½"
- Connecting cable for remote version:
- Cable entry M20 × 1.5 (8 to 12 mm / 0.31 to 0.47")
 - Thread for cable entries, ½" NPT, G ½"

Cable specifications, remote version

- Coil current cable
- 2 × 0.75 mm² (18 AWG) PVC cable with common, braided copper shield (Ø ~ 7 mm / 0.28")
 - Conductor resistance: ≤ 37 Ω/km (≤ 0.011 Ω/ft)
 - Capacitance core/core, shield grounded: ≤ 120 pF/m (≤ 37 pF/ft)
 - Operating temperature: -20 to +80 °C (-68 to +176 °F)
 - Cable cross-section: max. 2.5 mm² (14 AWG)
 - Test voltage for cable insulation: ≤ 1433 AC r.m.s. 50/60 Hz or ≥ 2026 V DC
- Electrode cable
- 3 × 0.38 mm² (20 AWG) PVC cable with common, braided copper shield (Ø ~ 7 mm / 0.28") and individual shielded cores
 - With empty pipe detection (EPD): 4 × 0.38 mm² (20 AWG) PVC cable with common, braided copper shield (Ø ~ 7 mm / 0.28") and individual shielded cores
 - Conductor resistance: ≤ 50 Ω/km (≤ 0.015 Ω/ft)
 - Capacitance core/shield: ≤ 420 pF/m (≤ 128 pF/ft)
 - Operating temperature: -20 to +80 °C (-68 to +176 °F)
 - Cable cross-section: max. 2.5 mm² (14 AWG)

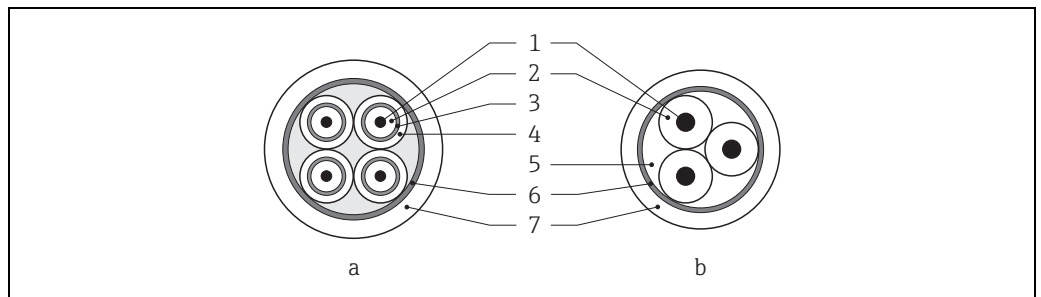

- a Electrode cable
 b Coil current cable
- 1 Core
 2 Core insulation
 3 Core shield
 4 Core jacket
 5 Core reinforcement
 6 Cable shield
 7 Outer jacket

Operation in zones of severe electrical interference

The measuring device complies with the general safety requirements in accordance with EN 61010 and the EMC requirements of IEC/EN 61326.



Note!

Grounding is by means of the ground terminals provided for the purpose inside the connection housing. Ensure that the stripped and twisted lengths of cable shield to the ground terminal are as short as possible.

Performance characteristics

Reference operating conditions

As per DIN EN 29104 and VDI/VDE 2641:

- Fluid temperature: $+28\text{ °C} \pm 2\text{ K}$ ($+82\text{ °F} \pm 2\text{ K}$)
- Ambient temperature: $+22\text{ °C} \pm 2\text{ K}$ ($+72\text{ °F} \pm 2\text{ K}$)
- Warm-up period: 30 minutes

Installation conditions:

- Inlet run $> 10 \times \text{DN}$
- Outlet run $> 5 \times \text{DN}$
- Sensor and transmitter grounded.
- The sensor is centered in the pipe.

Maximum measured error

- Current output: also typically $\pm 5\ \mu\text{A}$
- Pulse output: $\pm 0.5\% \text{ o.r.} \pm 2\text{ mm/s}$ ($\pm 0.5\% \text{ o.r.} \pm 0.08\text{ in/s}$) (o.r. = of reading)

Fluctuations in the supply voltage do not have any effect within the specified range.

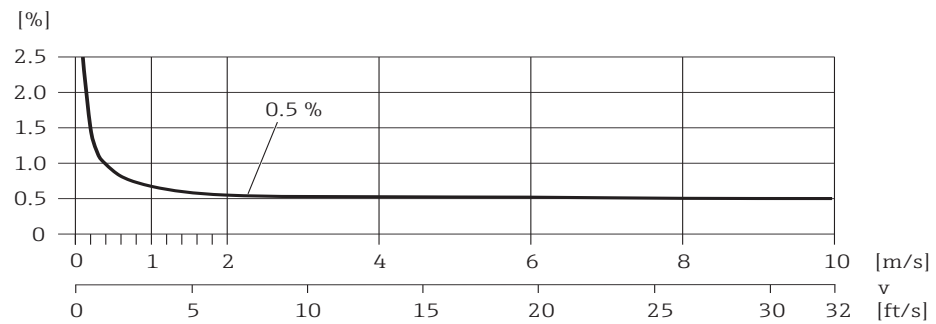

Max. measured error in % of reading

A0003200

Repeatability

Max. $\pm 0.2\% \text{ o.r.} \pm 2\text{ mm/s}$ ($\pm 0.2\% \text{ o.r.} \pm 0.08\text{ in/s}$) (o.r. = of reading)

Installation

Mounting location

Entrained air or gas bubble formation in the measuring tube can result in an increase in measuring errors.

Avoid the following installation locations in the pipe:

- Highest point of a pipeline. Risk of air accumulating!
- Directly upstream from a free pipe outlet in a vertical pipeline.

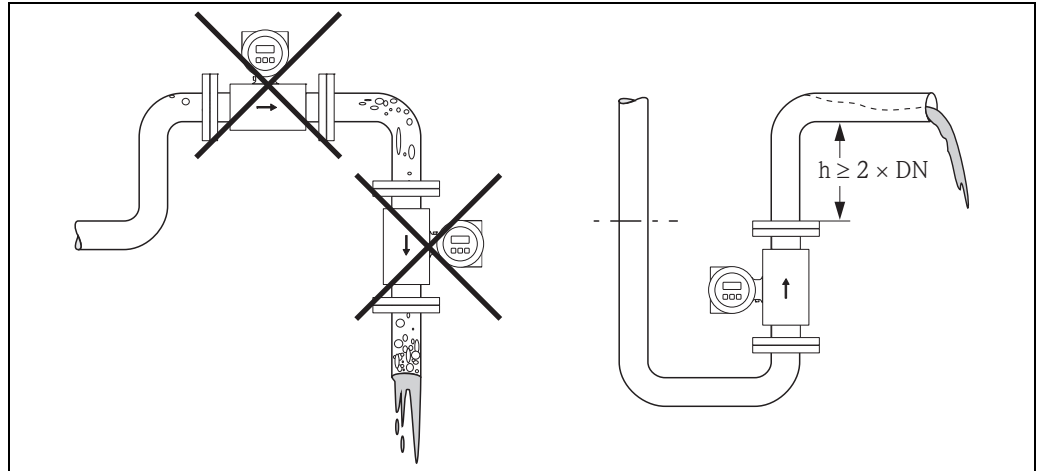

A0003202

Installation of pumps

Sensors may not be installed on the pump suction side. This precaution is to avoid low pressure and the consequent risk of damage to the lining of the measuring tube. Information on the pressure tightness of the measuring tube lining → 16, Section "Pressure tightness".

Pulsation dampers may be needed when using piston pumps, piston diaphragm pumps or hose pumps. Information on the shock and vibration resistance of the measuring system → 13, Section "Shock and vibration resistance".

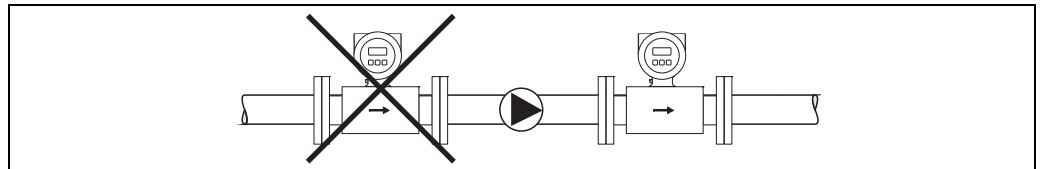

A0003203

Installation in down pipes

Install a siphon or a vent valve downstream of the sensor in down pipes $h \geq 5$ m (16.4 ft). This precaution is to avoid low pressure and the consequent risk of damage to the lining of the measuring tube. This measure also prevents the liquid current stopping in the pipe which could cause air locks. Information on the pressure tightness of the measuring tube lining → 16, Section "Pressure tightness".

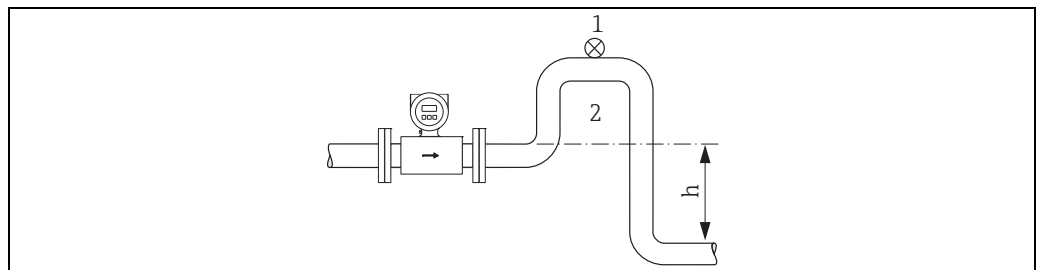

A0008157

Installation measures for vertical pipes

- 1 Vent valve
- 2 Pipe siphon
- h Length of the down pipe

Installation in partially filled pipes

Partially filled pipes with gradients necessitate a drain-type configuration.

The empty pipe detection function (EPD) provides additional security in detecting empty or partially filled pipes.



Note!

Risk of solids accumulating. Do not install the sensor at the lowest point in the drain. It is advisable to install a cleaning valve.

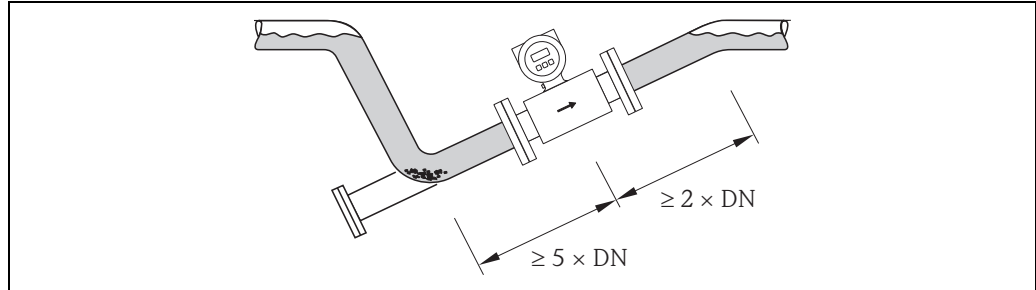

A0003204

Orientation

An optimum orientation helps avoid gas and air accumulations and deposits in the measuring tube. However, the measuring device also offers the additional function of empty pipe detection (EPD) for detecting partially filled measuring tubes or if outgassing fluids or fluctuating operating pressures are present.

Vertical orientation

This is the ideal orientation for self-emptying piping systems and for use in conjunction with empty pipe detection.

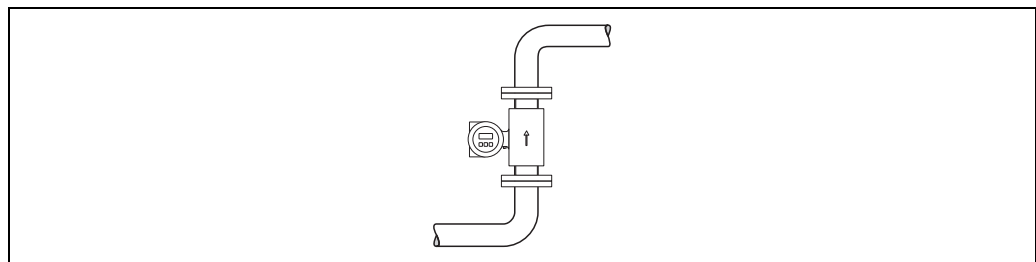

A0008158

Horizontal orientation

The measuring electrode axis should be horizontal. This prevents brief insulation of the two measuring electrodes by entrained air bubbles.



Note!

Empty pipe detection only works correctly with horizontal orientation if the transmitter housing is facing upwards. Otherwise there is no guarantee that empty pipe detection will respond if the measuring tube is only partially filled or empty.

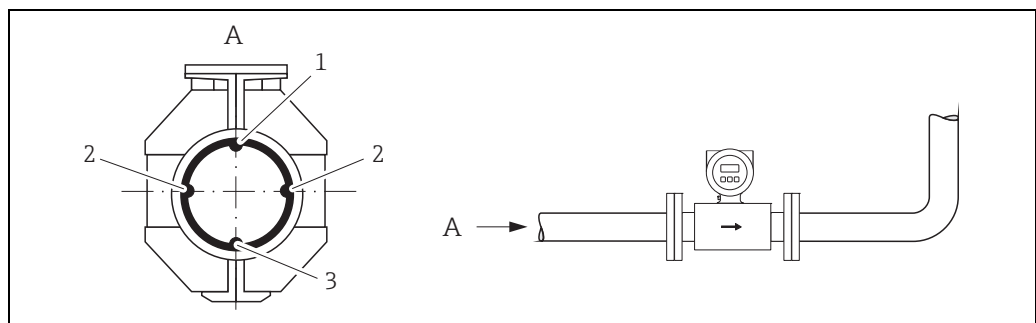

A0003207

Horizontal orientation

- 1 EPD electrode for empty pipe detection
- 2 Measuring electrodes for signal detection
- 3 Reference electrode for potential equalization

Inlet and outlet run

If possible, install the sensor well clear of assemblies such as valves, T-pieces, elbows etc.

Note the following inlet and outlet runs to comply with measuring accuracy specifications:

- Inlet run: $\geq 5 \times \text{DN}$
- Outlet run: $\geq 2 \times \text{DN}$

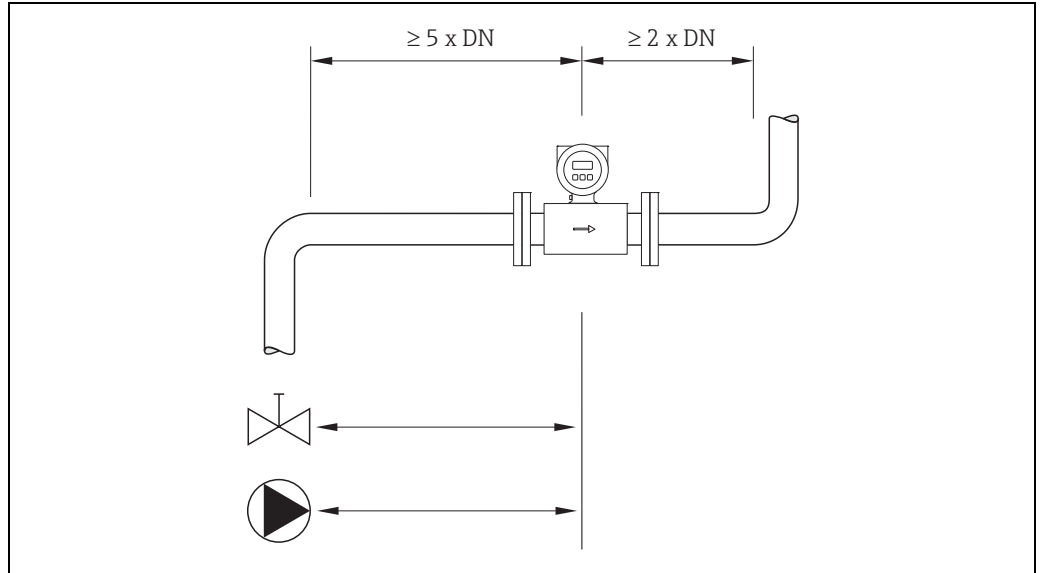

Inlet and outlet run

A0003210

Adapters

Suitable adapters to DIN EN 545 (double-flange reducers) can be used to install the sensor in larger-diameter pipes. The resultant increase in the rate of flow improves measuring accuracy with very slow-moving fluids. The nomogram shown here can be used to calculate the pressure loss caused by reducers and expanders.



Note!

The nomogram only applies to liquids of viscosity similar to water.

1. Calculate the ratio of the diameters d/D .
2. From the nomogram read off the pressure loss as a function of flow velocity (downstream from the reduction) and the d/D ratio.

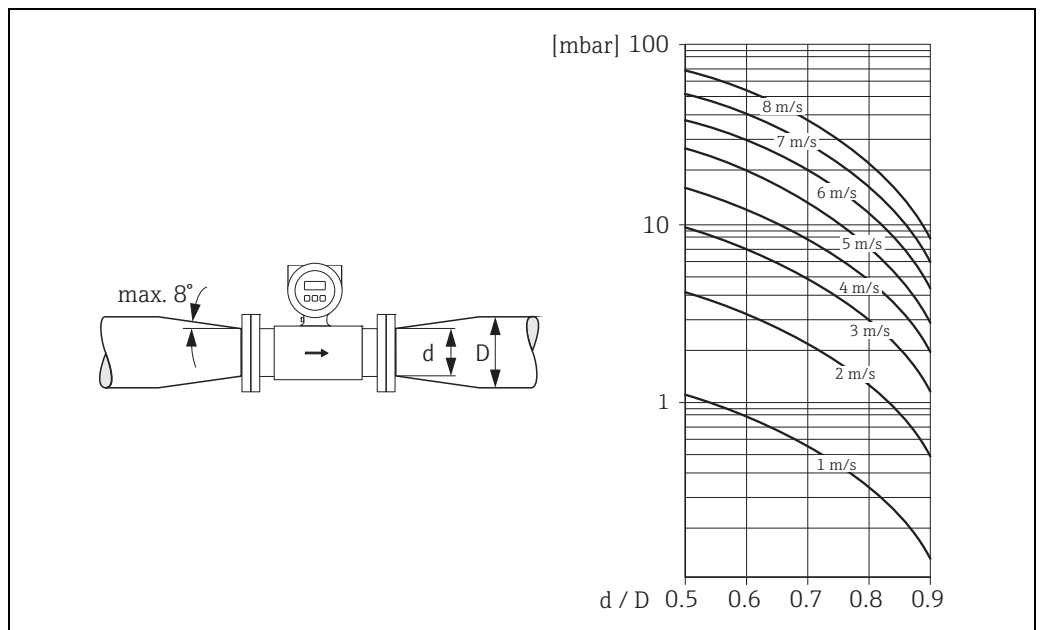

Pressure loss due to adapters

A0003213

Length of connecting cable

When mounting the remote version, please note the following to achieve correct measuring results:

- Fix cable run or lay in armored conduit. Cable movements can falsify the measuring signal especially in the case of low fluid conductivities.
- Route the cable well clear of electrical machines and switching elements.
- If necessary, ensure potential equalization between sensor and transmitter.
- The permitted cable length L_{\max} is determined by the fluid conductivity. A minimum conductivity of $50 \mu\text{S}/\text{cm}$ is needed for all fluids.
- When the empty pipe detection function is switched on (EPD), the maximum connecting cable length is 10 m (33 ft).

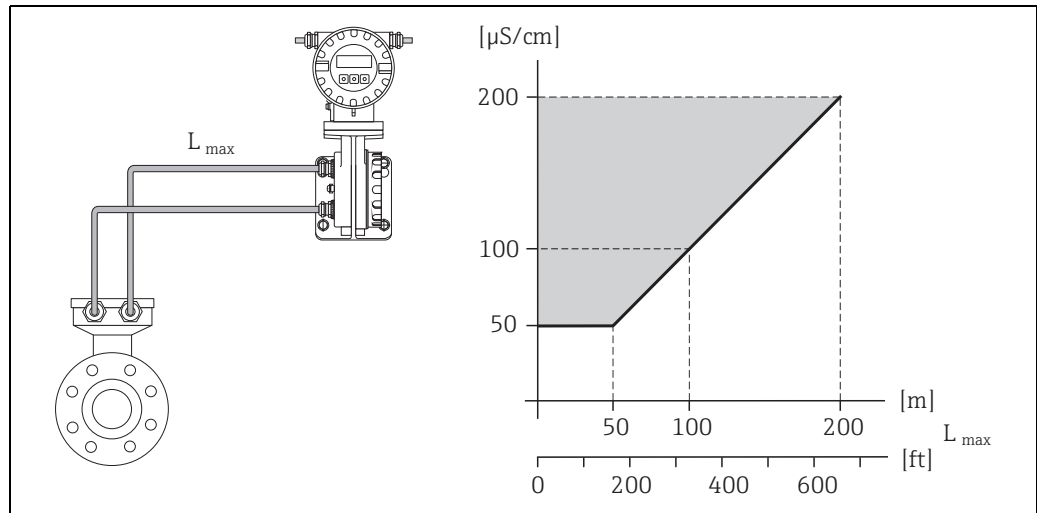

Permitted length of connecting cable for remote version

Area marked in gray = permitted range; L_{\max} = length of connecting cable in [m] ([ft]); fluid conductivity in [$\mu\text{S}/\text{cm}$]

A0003214

Environment

Ambient temperature range

Transmitter

- -20 to +60 °C (-4 to +140 °F)

Sensor

- Flange material carbon steel: -10 to +60 °C (14 to +140 °F)



Note!

The permitted temperature range of the measuring tube lining may not be undershot or overshoot (→  14, Section "Medium temperature range").

Please note the following points:

- Install the device in a shady location. Avoid direct sunlight, particularly in warm climatic regions.
 - The transmitter must be mounted separate from the sensor if both the ambient and fluid temperatures are high.
-

Storage temperature

The storage temperature corresponds to the operating temperature range of the measuring transmitter and the appropriate measuring sensors.



Note!

- The measuring device must be protected against direct sunlight during storage in order to avoid unacceptably high surface temperatures.
 - A storage location must be selected where moisture does not collect in the measuring device. This will help prevent fungus and bacteria infestation which can damage the liner.
-

Degree of protection

Standard: IP 67 (NEMA 4X) for transmitter and sensor.

Shock and vibration resistance

Acceleration up to 2 g following IEC 600 68-2-6

Electromagnetic compatibility (EMC)

- As per IEC/EN 61326
- Emission: to limit value for industry EN 55011

Process

Medium temperature range PTFE: -10 to +110 °C (+14 to +230 °F)

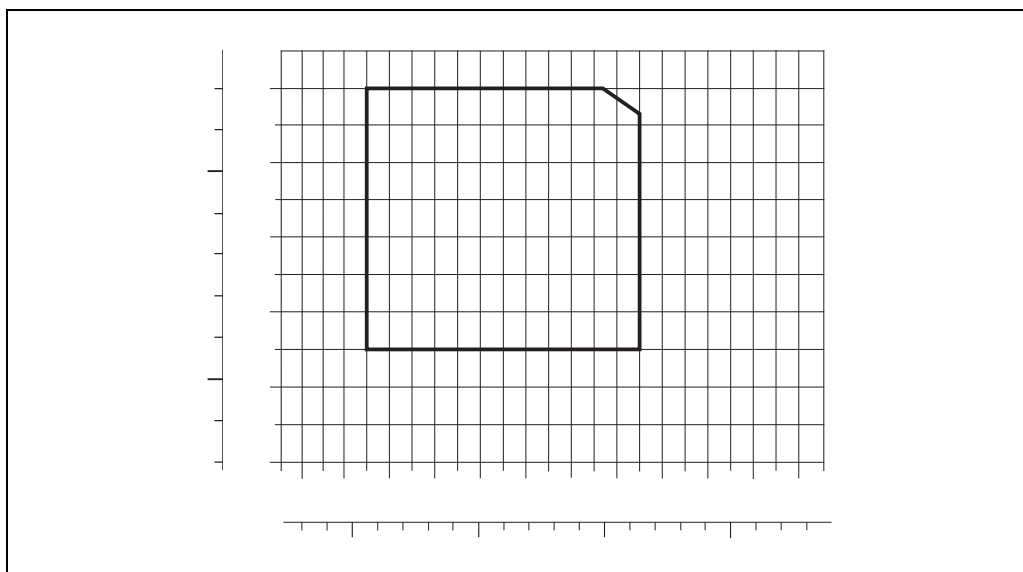

Compact and remote version (T_A = ambient temperature range, T_F = fluid temperature)

Conductivity



The minimum conductivity is: $\geq 50 \mu\text{S}/\text{cm}$

Note!

In the remote version, the necessary minimum conductivity also depends on the cable length (\rightarrow 12, Section "Length of connecting cable").

Pressure-temperature ratings



Note!

The following diagrams contain material load diagrams (reference curves) for flange materials with regard to the medium temperature. However, the maximum medium temperatures permitted always depend on the lining material of the sensor and/or the sealing material (\rightarrow 14).

Process connection: flange to EN 1092-1 (DIN 2501)

Material process connection: S235JRG2, S235JR+N, P250GH, P245GH, E250C, A105

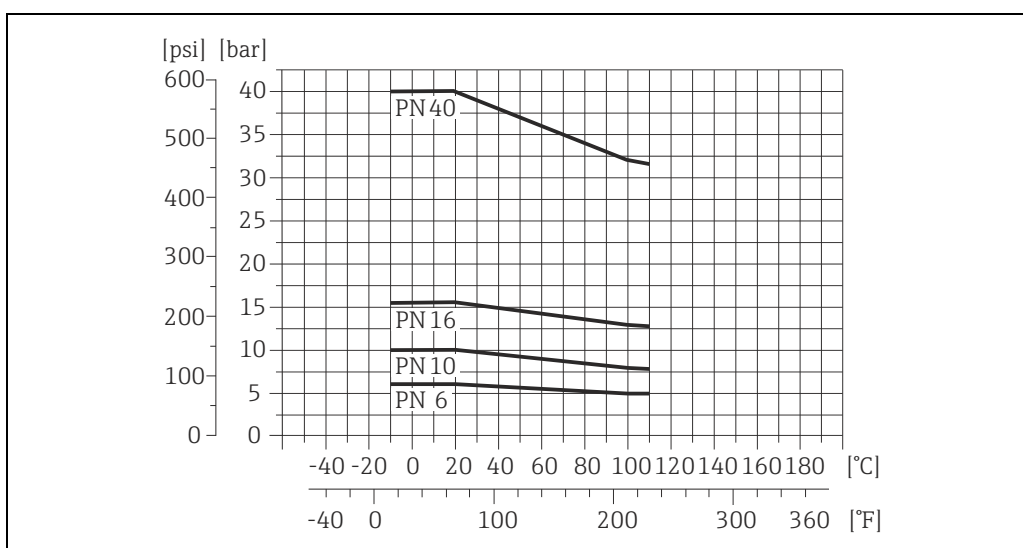

Process connection: flange to ASME B16.5

Material process connection: A105

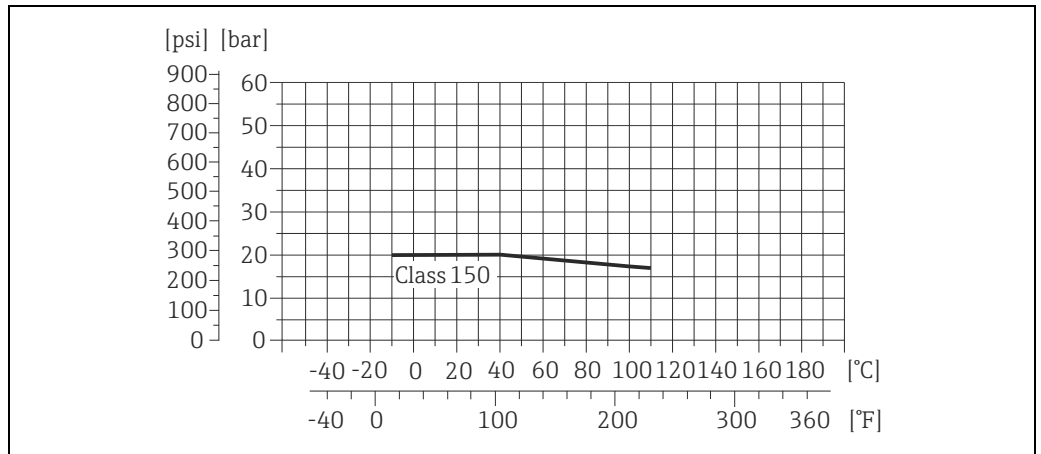

A0022939-EN

Process connection: flange to JIS B2220

Material: A105, A350 LF2, F316L

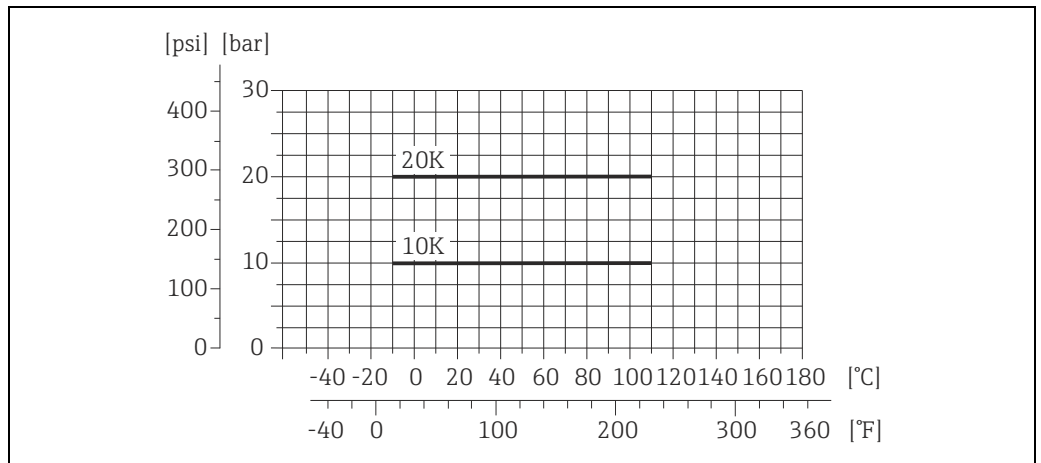

A0022940-EN

**Medium pressure range
(nominal pressure)**

- EN 1092-1 (DIN 2501)
 - PN 6 (DN 350 to 600 / 14 to 24")
 - PN 10 (DN 200 to 600 / 8 to 24")
 - PN 16 (DN 65 to 600 / 3 to 24")
 - PN 40 (DN 15 to 50 / ½ to 2")
- ASME B 16.5
 - Class 150 (DN 15 to 600 / ½ to 24")
- JIS B2220
 - 10K (DN 50 to 300 / 2 to 12")
 - 20K (DN 15 to 40 / ½ to 1½")

Pressure tightness

Measuring tube lining: PTFE

Nominal diameter		Limit values for abs. pressure [mbar] ([psi]) at fluid temperatures:							
		25 °C (77 °F)		80 °C (176 °F)		100 °C (212 °F)		110 °C (230 °F)	
[mm]	[inch]	[mbar]	[psi]	[mbar]	[psi]	[mbar]	[psi]	[mbar]	[psi]
15	½"	0	0	0	0	0	0	100	1.45
25	1"	0	0	0	0	0	0	100	1.45
32	–	0	0	0	0	0	0	100	1.45
40	1½"	0	0	0	0	0	0	100	1.45
50	2"	0	0	0	0	0	0	100	1.45
65	–	0	0	*	*	40	0.58	130	1.89
80	3"	0	0	*	*	40	0.58	130	1.89
100	4"	0	0	*	*	135	1.96	170	2.47
125	–	135	1.96	*	*	240	3.48	385	5.58
150	6"	135	1.96	*	*	240	3.48	385	5.58
200	8"	200	2.90	*	*	290	4.21	410	5.95
250	10"	330	4.79	*	*	400	5.80	530	7.69
300	12"	400	5.80	*	*	500	7.25	630	9.14
350	14"	470	6.82	*	*	600	8.70	730	10.6
400	16"	540	7.83	*	*	670	9.72	800	11.6
450	18"	Partial vacuum is impermissible!							
500	20"								
600	24"								

* No value can be specified.

Limiting flow

The diameter of the pipe and the flow rate determine the nominal diameter of the sensor. The optimum flow velocity is between 2 to 3 m/s (6.5 to 9.8 ft/s). The velocity of flow (v), moreover, has to be matched to the physical properties of the fluid:

- $v < 2$ m/s (6.5 ft/s): for abrasive fluids such as potter's clay, lime milk, ore slurry etc.
- $v > 2$ m/s (6.5 ft/s): for fluids causing build-up such as wastewater sludges etc.

Flow characteristic values (SI units)						
Diameter		Recommended flow rate Min./max. full scale value ($v \sim 0.3$ or 10 m/s)	Factory settings			
[mm]	[inch]		Full scale value, current output ($v \sim 2.5$ m/s)	Pulse value (~ 2 pulses/s)	Low flow cut off ($v \sim 0.04$ m/s)	
15	½"	4 to 100 dm ³ /min	25 dm ³ /min	0.20 dm ³	0.50 dm ³ /min	
25	1"	9 to 300 dm ³ /min	75 dm ³ /min	0.50 dm ³	1.00 dm ³ /min	
32	–	15 to 500 dm ³ /min	125 dm ³ /min	1.00 dm ³	2.00 dm ³ /min	
40	1½"	25 to 700 dm ³ /min	200 dm ³ /min	1.50 dm ³	3.00 dm ³ /min	
50	2"	35 to 1100 dm ³ /min	300 dm ³ /min	2.50 dm ³	5.00 dm ³ /min	
65	–	60 to 2000 dm ³ /min	500 dm ³ /min	5.00 dm ³	8.00 dm ³ /min	
80	3"	90 to 3000 dm ³ /min	750 dm ³ /min	5.00 dm ³	12.0 dm ³ /min	
100	4"	145 to 4700 dm ³ /min	1200 dm ³ /min	10.0 dm ³	20.0 dm ³ /min	
125	–	220 to 7500 dm ³ /min	1850 dm ³ /min	15.0 dm ³	30.0 dm ³ /min	
150	6"	20 to 600 m ³ /h	150 m ³ /h	0.03 m ³	2.50 m ³ /h	
200	8"	35 to 1100 m ³ /h	300 m ³ /h	0.05 m ³	5.00 m ³ /h	
250	10"	55 to 1700 m ³ /h	500 m ³ /h	0.05 m ³	7.50 m ³ /h	
300	12"	80 to 2400 m ³ /h	750 m ³ /h	0.10 m ³	10.0 m ³ /h	

Flow characteristic values (SI units)					
Diameter		Recommended flow rate Min./max. full scale value (v ~ 0.3 or 10 m/s)	Factory settings		
[mm]	[inch]		Full scale value, current output (v ~ 2.5 m/s)	Pulse value (~ 2 pulses/s)	Low flow cut off (v ~ 0.04 m/s)
350	14"	110 to 3300 m ³ /h	1000 m ³ /h	0.10 m ³	15.0 m ³ /h
400	16"	140 to 4200 m ³ /h	1200 m ³ /h	0.15 m ³	20.0 m ³ /h
450	18"	180 to 5400 m ³ /h	1500 m ³ /h	0.25 m ³	25.0 m ³ /h
500	20"	220 to 6600 m ³ /h	2000 m ³ /h	0.25 m ³	30.0 m ³ /h
600	24"	310 to 9600 m ³ /h	2500 m ³ /h	0.30 m ³	40.0 m ³ /h

Flow characteristic values (US units)					
Diameter		Recommended flow rate Min./max. full scale value (v ~ 0.3 or 10 m/s)	Factory settings		
[inch]	[mm]		Full scale value, current output (v ~ 2.5 m/s)	Pulse value (~ 2 pulses/s)	Low flow cut off (v ~ 0.04 m/s)
½"	15	1.0 to 26 gal/min	6 gal/min	0.10 gal	0.15 gal/min
1"	25	2.5 to 80 gal/min	18 gal/min	0.20 gal	0.25 gal/min
1½"	40	7 to 190 gal/min	50 gal/min	0.50 gal	0.75 gal/min
2"	50	10 to 300 gal/min	75 gal/min	0.50 gal	1.25 gal/min
3"	80	24 to 800 gal/min	200 gal/min	2.00 gal	2.50 gal/min
4"	100	40 to 1250 gal/min	300 gal/min	2.00 gal	4.00 gal/min
6"	150	90 to 2650 gal/min	600 gal/min	5.00 gal	12.0 gal/min
8"	200	155 to 4850 gal/min	1200 gal/min	10.0 gal	15.0 gal/min
10"	250	250 to 7500 gal/min	1500 gal/min	15.0 gal	30.0 gal/min
12"	300	350 to 10600 gal/min	2400 gal/min	25.0 gal	45.0 gal/min
14"	350	500 to 15000 gal/min	3600 gal/min	30.0 gal	60.0 gal/min
16"	400	600 to 19000 gal/min	4800 gal/min	50.0 gal	60.0 gal/min
18"	450	800 to 24000 gal/min	6000 gal/min	50.0 gal	90.0 gal/min
20"	500	1000 to 30000 gal/min	7500 gal/min	75.0 gal	120.0 gal/min
24"	600	1400 to 44000 gal/min	10500 gal/min	100.0 gal	180.0 gal/min

Pressure loss

- No pressure loss if the sensor is installed in a pipe with the same nominal diameter.
- Pressure losses for configurations incorporating adapters according to DIN EN 545 (→ 11, Section "Adapters").

Vibrations



Secure the piping and the sensor if vibration is severe.

Note!

If vibrations are too severe, we recommend the sensor and transmitter be mounted separately. Information on the permitted shock and vibration resistance → 13, Section "Shock and vibration resistance".

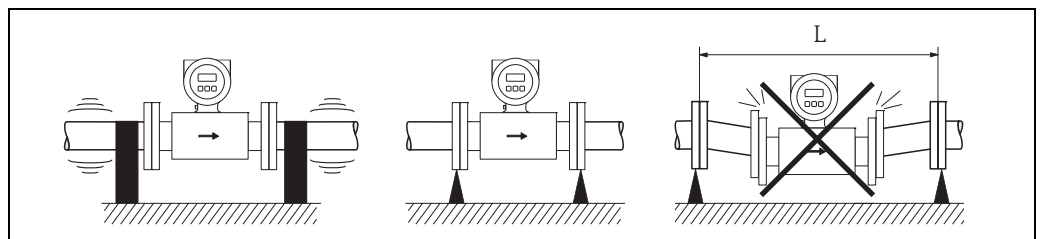

Measures to prevent vibration of the measuring device

L > 10 m (33 ft)

Mechanical construction

Design, dimensions

Compact version DN 15 to 300 (½ to 12")

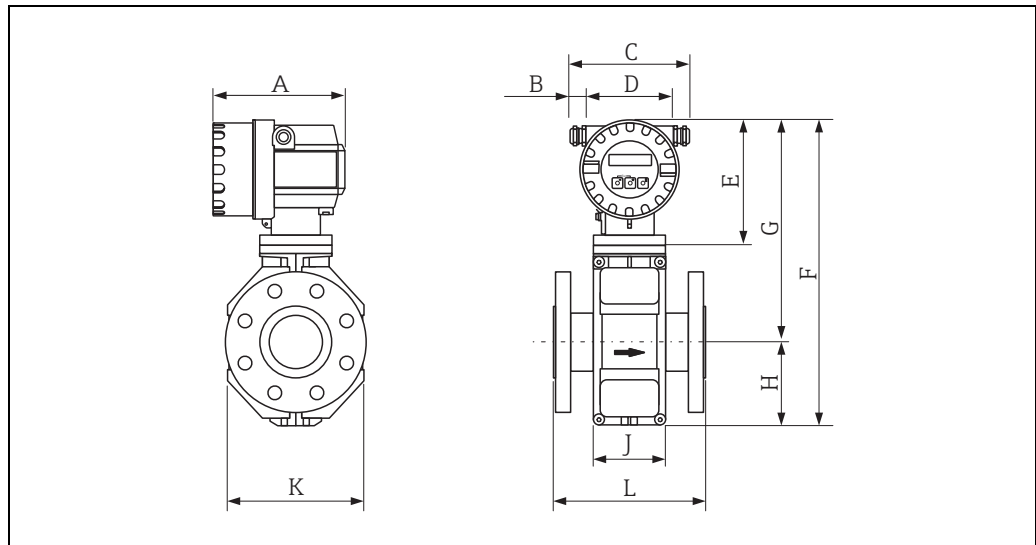

A0012464

Dimensions in SI units

DN	L ¹⁾	A	B	C	D	E	F	G	H	J	K
EN (DIN) / JIS											
15	200	178	20 to 30	161 to 181	113	150	341	257	84	94	120
25	200						341	257	84	94	120
32	200						341	257	84	94	120
40	200						341	257	84	94	120
50	200						341	257	84	94	120
65	200						391	282	109	94	180
80	200						391	282	109	94	180
100	250						391	282	109	94	180
125	250						472	322	150	140	260
150	300						472	322	150	140	260
200	350						527	347	180	156	324
250	450						577	372	205	156	400
300	500						627	397	230	166	460

¹⁾ The length (L) is regardless of the pressure rating selected. Fitting length to DVGW.
All dimensions in [mm]

Dimensions in US units

DN ASME	L ¹⁾	A	B	C	D	E	F	G	H	J	K
½"	7.87	7.01	0.79 to 1.81	6.34 to 7.13	4.45	5.91	13.4	10.1	3.32	3.70	4.72
1"	7.87						13.4	10.1	3.32	3.70	4.72
1½"	7.87						13.4	10.1	3.32	3.70	4.72
2"	7.87						13.4	10.1	3.32	3.70	4.72
3"	7.87						15.4	11.1	4.30	3.70	7.10
4"	9.84						15.4	11.1	4.30	3.70	7.10
6"	11.8						18.6	12.7	5.91	5.51	10.2
8"	13.8						20.8	13.7	7.10	6.14	12.8
10"	17.7						22.7	14.7	8.08	6.14	15.8
12"	19.7						24.7	15.6	9.06	6.54	18.1

¹⁾ The length (L) is regardless of the pressure rating selected. Fitting length to DVGW.
All dimensions in [inch]

Compact version DN 350 to 600 (14 to 24")

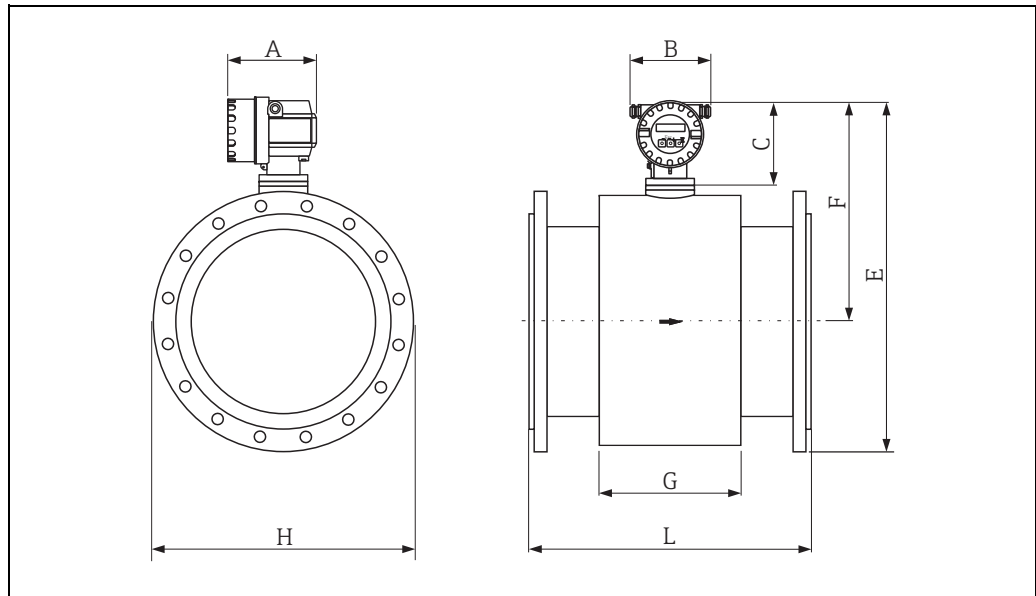

A0014993

Dimensions (SI units)

DN	L	A	B	C	F	G
350	550	178	161 to 181	150	401	290
400	600				427	290
450	600				455	290
500	600				480	290
600	600				521	290

All dimensions in [mm]

DN	E at pressure rating				H at pressure rating			
	PN 6	PN 10	PN 16	ASME	PN 6	PN 10	PN 16	ASME
350	646	653	661	667	490	505	520	533
400	697	709	717	725	540	565	580	597
450	752	762	775	772	595	615	640	635
500	802	815	837	829	645	670	715	699
600	898	911	941	927	755	780	840	813

All dimensions in [mm]

Dimensions (US units)

DN	L	A	B	C	F	G
14"	21.6	7.00	6.34 to 7.13	5.91	15.8	11.4
16"	23.6				16.8	11.4
18"	23.6				17.9	11.4
20"	23.6				18.9	11.4
24"	23.6				20.5	11.4

All dimensions in [inch]

DN	E at pressure rating				H at pressure rating			
	PN 6	PN 10	PN 16	ASME	PN 6	PN 10	PN 16	ASME
14"	25.4	25.7	26.0	26.3	19.3	19.9	20.5	21.0
16"	27.4	27.9	28.2	28.5	21.3	22.2	22.8	23.5
18"	29.6	30.0	30.5	30.4	23.4	24.2	25.2	25.0
20"	31.6	32.1	33.0	32.6	25.4	26.4	28.2	27.5
24"	35.4	35.9	37.1	36.5	29.7	30.7	33.1	32.0

All dimensions in [inch]

Transmitter, remote version

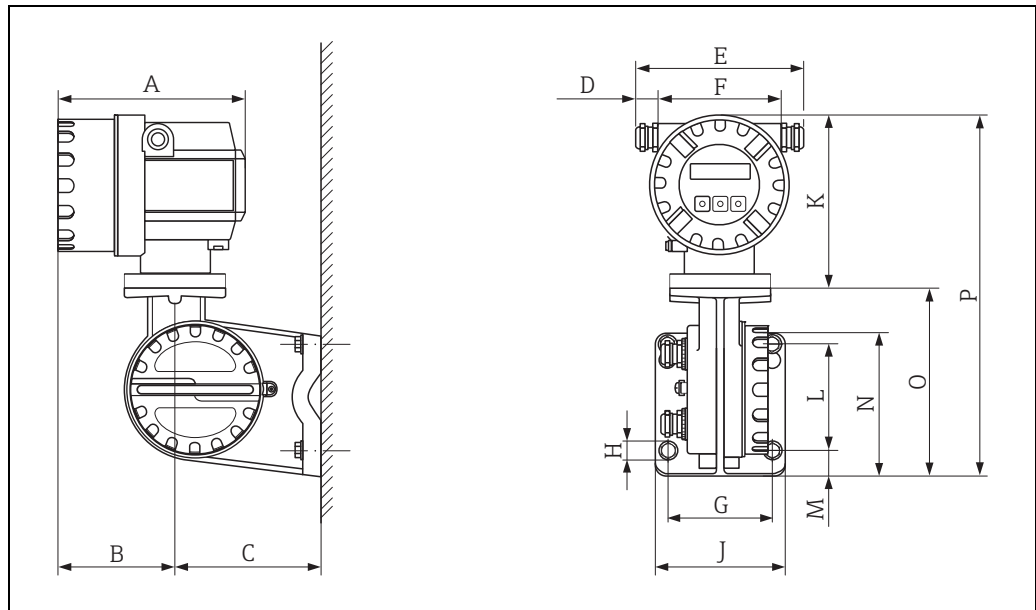

A0010718

Transmitter dimensions, remote version

Dimensions in SI units

A	B	C	D	E	F	G	Ø H
178	113	135	20 to 30	161 to 181	121	100	8.6 (M8)
J	K	L	M	N	O	P	
123	150	100	25	133	177.5	327.5	

All dimensions in [mm]

Dimensions in US units

A	B	C	D	E	F	G	Ø H
7.00	4.45	5.31	0.79 to 1.81	6.34 to 7.13	4.76	3.94	0.34 (M8)
J	K	L	M	N	O	P	
4.84	5.90	3.94	0.98	5.24	6.99	12.89	

All dimensions in [inch]

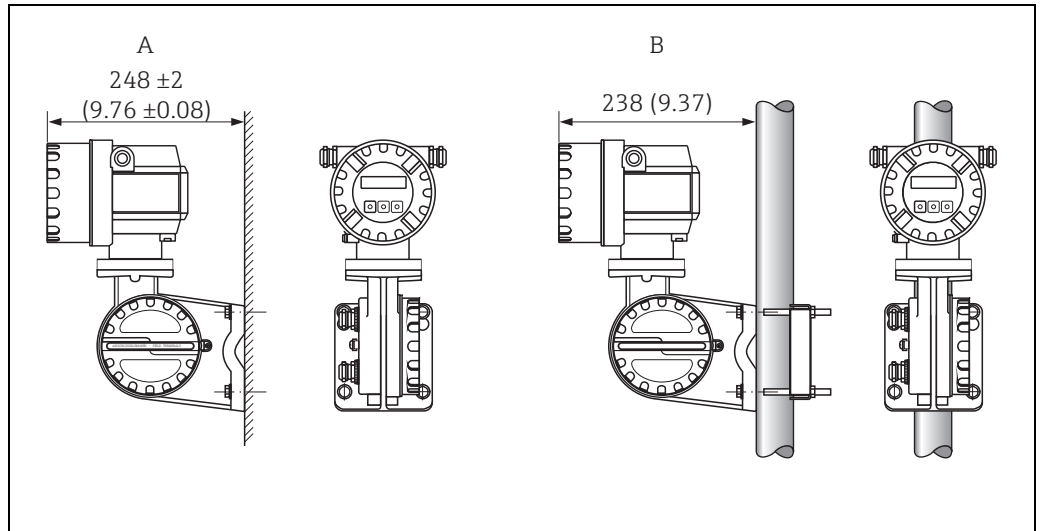

A0010719

Transmitter mounting, remote version. Engineering unit mm (in)

- A Direct wall mounting
- B Pipe mounting

Sensor, remote version DN 15 to 300 (½ to 12")

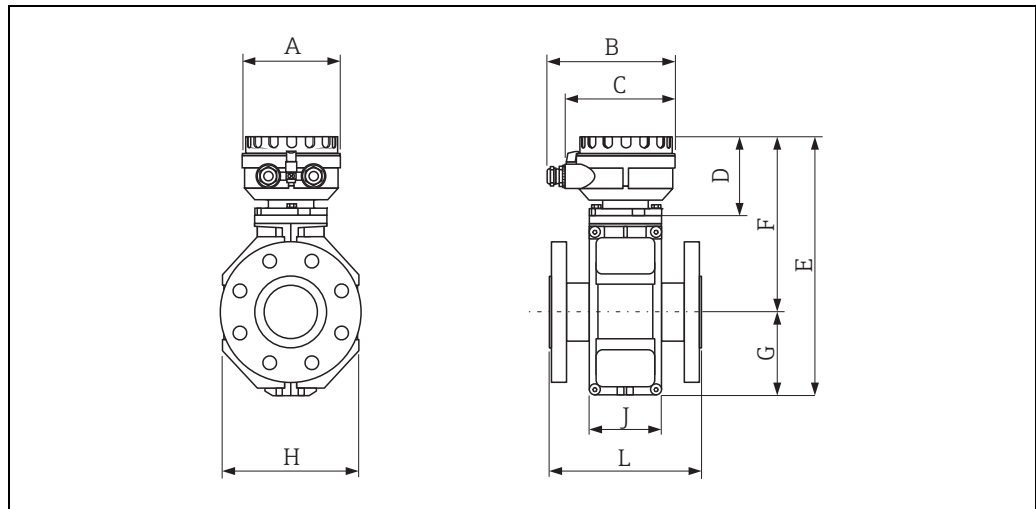

A0012462

Dimensions in SI units

DN EN (DIN) / JIS	L ¹⁾	A	B	C	D	E	F	G	H	J
15	200	129	163	143	102	286	202	84	120	94
25	200					286	202	84	120	94
32	200					286	202	84	120	94
40	200					286	202	84	120	94
50	200					286	202	84	120	94
65	200					336	227	109	180	94
80	200					336	227	109	180	94
100	250					336	227	109	180	94
125	250					417	267	150	260	140
150	300					417	267	150	260	140
200	350					472	292	180	324	156
250	450					522	317	205	400	156
300	500					572	342	230	460	166

¹⁾ The length (L) is regardless of the pressure rating selected. Fitting length to DVGW.
All dimensions in [mm]

Dimensions in US units

DN ASME	L ¹⁾	A	B	C	D	E	F	G	H	J
½"	7.87	5.08	6.42	5.63	4.02	11.3	7.95	3.32	4.72	3.70
1"	7.87					11.3	7.95	3.32	4.72	3.70
1½"	7.87					11.3	7.95	3.32	4.72	3.70
2"	7.87					11.3	7.95	3.32	4.72	3.70
3"	7.87					13.2	8.94	4.30	7.10	3.70
4"	9.84					13.2	8.94	4.30	7.10	3.70
6"	11.8					16.4	10.5	5.91	10.2	5.51
8"	13.8					18.6	11.5	7.10	12.8	6.14
10"	17.7					20.6	12.5	8.08	15.8	6.14
12"	19.7					22.5	13.5	9.06	18.1	6.54

¹⁾ The length (L) is regardless of the pressure rating selected. Fitting length to DVGW.
All dimensions in [inch]

Sensor, remote version DN 350 to 600 (14 to 24")

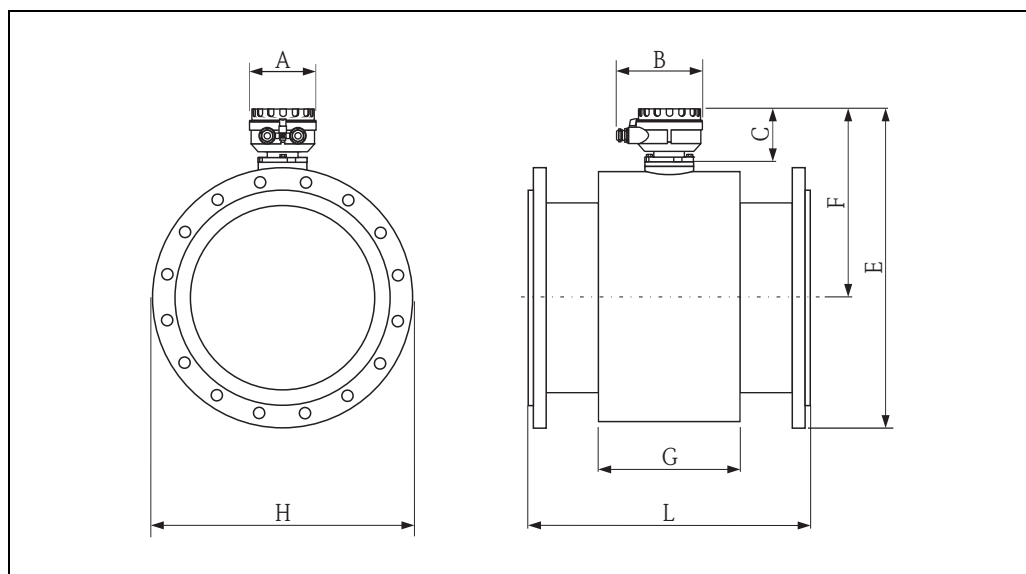

Dimensions (SI units)

DN	L	A	B	C	F	G
350	550	129	163	102	353	290
400	600				379	290
450	600				407	290
500	600				432	290
600	600				473	290

All dimensions in [mm]

DN	E at pressure rating				H at pressure rating			
	PN 6	PN 10	PN 16	ASME	PN 6	PN 10	PN 16	ASME
350	598	605	613	619	490	505	520	533
400	649	661	669	677	540	565	580	597
450	704	714	727	724	595	615	640	635
500	754	767	789	781	645	670	715	699
600	850	863	893	879	755	780	840	813

All dimensions in [mm]

Dimensions (US units)

DN	L	A	A*	B	C	D	F	G
14"	21.6	5.08	6.42	4.02	13.9	11.4	21.6	5.08
16"	23.6				14.9	11.4	23.6	
18"	23.6				16.0	11.4	23.6	
20"	23.6				17.0	11.4	23.6	
24"	23.6				18.6	11.4	23.6	

All dimensions in [inch]

DN	E at pressure rating				H at pressure rating			
	PN 6	PN 10	PN 16	ASME	PN 6	PN 10	PN 16	ASME
14"	23.5	23.8	24.1	24.4	19.93	19.9	20.5	21.0
16"	25.6	26.0	26.3	26.7	21.3	22.2	22.8	23.5
18"	27.7	28.1	28.6	28.5	23.4	24.2	25.2	25.0
20"	29.7	30.2	31.1	30.7	25.4	26.4	28.1	27.5
24"	33.5	34.0	35.2	34.6	29.7	30.7	33.1	32.0

All dimensions in [inch]

Ground disk for flange connections

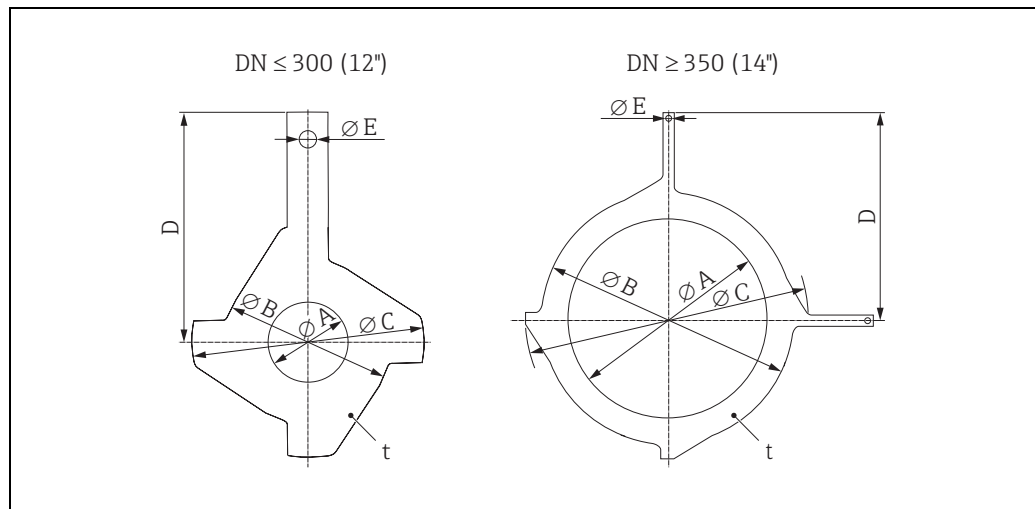

A0009221

Dimensions (SI units)

DN ¹⁾ EN (DIN) / JIS	A	B	C	D	E	t
15	16	43	761.5	73.0	6.5	2
25	26	62	77.5	87.5		
32	35	80	87.5	94.5		
40	41	82	101	103		
50	52	101	115.5	108		
65	68	121	131.5	118		
80	80	131	154.5	135		
100	104	156	186.5	153		
125	130	187	206.5	160		
150	158	217	256	184		
200	206	267	288	205		
250	260	328	359	240		
300 ²⁾	312	375	413	273		
300 ³⁾	310	375	404	268		
350 ²⁾	343	420	479	365	9.0	
400 ²⁾	393	470	542	395		
450 ²⁾	439	525	583	417		
500 ²⁾	493	575	650	460		
600 ²⁾	593	676	766	522		

¹⁾ Ground disks at DN 15 to 250 (½ to 10") can be used for all flange standards/pressure ratings.

²⁾ PN 10/16

³⁾ JIS 10K

All dimensions in [mm]

Dimensions (US units)

DN ¹⁾ ASME	A	B	C	D	E	t	
½"	0.63	1.69	2.42	2.87	0.26	0.08	
1"	1.02	2.44	3.05	3.44			
1½"	1.61	3.23	3.98	4.06			
2"	2.05	3.98	4.55	4.25			
3"	3.15	5.16	6.08	5.31			
4"	4.09	6.14	7.34	6.02			
6"	6.22	8.54	10.1	7.24			
8"	8.11	10.5	11.3	8.07			
10"	10.2	12.9	14.1	9.45			
12"	12.3	14.8	16.3	10.8			
14"	13.5	16.5	18.9	14.4			0.35
16"	15.5	18.5	21.3	15.6			
18"	17.3	20.7	23.0	16.4			
20"	19.4	22.6	25.6	18.1			
24"	23.4	26.6	30.2	20.6			

¹⁾ Ground disks can be used for all flange standards/pressure ratings.
All dimensions in [inch]

Weight

Weight in SI units

Weight data in kg							
Nominal diameter		Compact version					
		EN (DIN)				ASME	JIS
[mm]	[inch]	PN 6	PN 10	PN 16	PN 40	Class 150	10K
15	½"	-	-	-	6.5	6.5	6.5
25	1"	-	-	-	7.3	7.3	7.3
32	-	-	-	-	8.0	-	7.3
40	1½"	-	-	-	9.4	9.4	8.3
50	2"	-	-	-	10.6	10.6	9.3
65	-	-	-	12.0	-	-	11.1
80	3"	-	-	14.0	-	14.0	12.5
100	4"	-	-	16.0	-	16.0	14.7
125	-	-	-	21.5	-	-	21.0
150	6"	-	-	25.5	-	25.5	24.5
200	8"	-	45.0	46.0	-	45.0	41.9
250	10"	-	65.0	70.0	-	75.0	69.4
300	12"	-	70.0	81.0	-	110.0	72.3
350	14"	77.4	88.4	104	-	137.4	-
400	16"	89.4	104.4	125	-	168.4	-
450	18"	103	118	149	-	193	-
500	20"	115	132.4	190	-	228.4	-
600	24"	155.4	181	300	-	329	-

- Transmitter (compact version): 1.8 kg
- Weight data without packaging material

Weight data in kg								
Nominal diameter		Remote version (without cable)						Transmitter
		Sensor				ASME		
[mm]	[inch]	EN (DIN)				Class 150	10K	Wall-mount housing
		PN 6	PN 10	PN 16	PN 40			
15	½"	-	-	-	4.5	4.5	4.5	6.0
25	1"	-	-	-	5.3	5.3	5.3	
32	-	-	-	-	6.0	-	5.3	
40	1½"	-	-	-	7.4	7.4	6.3	
50	2"	-	-	-	8.6	8.6	7.3	
65	-	-	-	10.0	-	-	9.1	
80	3"	-	-	12.0	-	12.0	10.5	
100	4"	-	-	14.0	-	14.0	12.7	
125	-	-	-	19.5	-	-	19.0	
150	6"	-	-	23.5	-	23.5	22.5	
200	8"	-	43.0	44.0	-	43.0	39.9	
250	10"	-	63.0	68.0	-	73.0	67.4	
300	12"	-	68.0	79.0	-	108.0	70.3	
350	14"	73.1	84.1	100	-	133.1		
400	16"	85.1	100.1	121	-	164.1		
450	18"	99	114	145	-	189		
500	20"	111	128.1	186	-	224.1		
600	24"	158.1	177	296	-	325		

- Transmitter (remote version): 3.1 kg
- Weight data without packaging material

Weight in US units (ASME only)

Nominal diameter		Compact version	Remote version (without cable)	
		ASME	Sensor ASME	Transmitter
[mm]	[inch]	Class 150	Class 150	Wall-mount housing
15	½"	14.3	9.92	13.2
25	1"	16.1	11.7	
40	1½"	20.7	16.3	
50	2"	23.4	19.0	
80	3"	30.9	26.5	
100	4"	35.3	30.9	
150	6"	56.2	51.8	
200	8"	99.2	94.8	
250	10"	165.4	161.0	
300	12"	242.6	238.1	
350	14"	303.0	293.5	
400	16"	371.3	361.8	
450	18"	424	417	
500	20"	503.6	494.1	
600	24"	725	717	

- Transmitter: 4.0 lbs (compact version); 6.8 lbs (remote version)
- Weight data without packaging material

Measuring tube specifications

Diameter		Pressure rating			Internal diameter	
[mm]	[inch]	EN (DIN) [bar]	ASME [lbs]	JIS	PTFE [mm]	[inch]
15	½"	PN 40	Cl. 150	20K	14	0.55
25	1"	PN 40	Cl. 150	20K	26	1.02
32	-	PN 40	-	20K	34	1.34
40	1½"	PN 40	Cl. 150	20K	40	1.57
50	2"	PN 40	Cl. 150	10K	51	2.01
65	-	PN 16	-	10K	67	2.64
80	3"	PN 16	Cl. 150	10K	79	3.11
100	4"	PN 16	Cl. 150	10K	103	4.06
125	-	PN 16	-	10K	128	5.04
150	6"	PN 16	Cl. 150	10K	155	6.10
200	8"	PN 10/16	Cl. 150	10K	203	7.99
250	10"	PN 10	-	-	257	10.1
250	10"	PN 16	Cl. 150	10K	255	10.0
300	12"	PN 16	Cl. 150	10K	302	11.9
350	14"	PN 6/10	-	-	338	13.3
350	14"	PN 16	Cl. 150	10K	336	13.2
400	16"	PN 6/10	-	-	388	15.3
400	16"	PN 16	-	-	386	15.2
400	16"	-	Cl. 150	10K	384	15.1
450	18"	PN 6/10	-	-	440	17.3
450	18"	PN 16	-	-	438	17.2
450	18"	-	Cl. 150	10K	436	17.2
500	20"	PN 6/10	-	-	491	19.3
500	20"	PN 16	-	-	487	19.2
500	20"	-	Cl. 150	10K	485	19.1
600	24"	PN 6	-	-	592	23.3
600	24"	PN 10	-	-	590	23.2
600	24"	PN 16	-	-	588	23.2
600	24"	-	Cl. 150	10K	586	23.1

Material	<ul style="list-style-type: none"> ▪ Transmitter housing: powder-coated die-cast aluminum ▪ Sensor housing <ul style="list-style-type: none"> - DN 15 to 300 (½ to 12"): powder-coated die-cast aluminum - DN 350 to 600 (14 to 24"): with protective lacquering ▪ Measuring tube <ul style="list-style-type: none"> - DN ≤ 300 (12"): stainless steel 1.4301 (304) or 1.4306 (304L) (with Al/Zn protective coating) - DN ≥ 350 (14"): stainless steel 1.4301 (304) or 1.4306 (304L) (with protective lacquering) ▪ Electrodes: 1.4435 (316, 316L), Alloy C22 ▪ Flanges (with protective lacquering) <ul style="list-style-type: none"> - EN 1092-1 (DIN2501): carbon steel, S235JRG2, S235JR+N, P250GH, P245GH, E250C - ASME B16.5: carbon steel, A105 - JIS B2220: carbon steel, A105, A350 LF2 ▪ Seals: to DIN EN 1514-1 form IBC ▪ Ground disks: 1.4435 (316, 316L) or Alloy C22
Fitted electrodes	<p>Measuring electrodes, reference electrodes and empty pipe detection electrodes available as standard with:</p> <ul style="list-style-type: none"> ▪ 1.4435 (316, 316L) ▪ Alloy C22
Process connections	<p>Flange connection:</p> <ul style="list-style-type: none"> ▪ EN 1092-1 (DIN 2501), DN ≤ 300 (12") form A, DN ≥ 350 (14") form B (Dimensions to DIN 2501, DN 65 PN 16 and DN 600 (24") PN 16 exclusively to EN 1092-1) ▪ ASME B16.5 ▪ JIS B2220 ▪ AS 2129 ▪ AS 4087
Surface roughness	<p>Electrodes with 1.4435 (316, 316L), Alloy C22: ≤ 0.3 to 0.5 µm (11.8 to 19.7 µin) (All data refer to parts in contact with medium)</p>

Operability

Local operation	<p>Display elements</p> <ul style="list-style-type: none"> ▪ Liquid crystal display: unilluminated, two-line, 16 characters per line ▪ Display (operating mode) preconfigured: volume flow and totalizer status ▪ 1 totalizer <p>Operating elements</p> <p>Local operation via three keys (□ ⊕ ⊞)</p>
Remote operation	<p>Operation via HART protocol and FieldCare</p>

Certificates and approvals

CE mark	The measuring system is in conformity with the statutory requirements of the EC Directives. Endress+Hauser confirms successful testing of the device by affixing to it the CE mark.
C-tick symbol	The measuring system meets the EMC requirements of the "Australian Communications and Media Authority (ACMA)".
Ex approval	Information about currently available Ex versions (ATEX, FM, CSA etc.) can be supplied by your Endress+Hauser Sales Center on request. All explosion protection data are given in a separate documentation which is available upon request.
Other standards and guidelines	<ul style="list-style-type: none"> ■ EN 60529 Degrees of protection by housing (IP code) ■ EN 61010 Protection Measures for Electrical Equipment for Measurement, Control, Regulation and Laboratory Procedures. ■ IEC/EN 61326 "Emission in accordance with requirements for Class A". Electromagnetic compatibility (EMC requirements). ■ ANSI/ISA-S82.01 Safety Standard for Electrical and Electronic Test, Measuring, Controlling and related Equipment – General Requirements Pollution degree 2, Installation Category II. ■ CAN/CSA-C22.2 No. 1010.1-92 Safety requirements for Electrical Equipment for Measurement and Control and Laboratory Use. Pollution degree 2, Installation Category II
Pressure measuring device approval	<p>The devices can be ordered with or without a PED approval. If a device with a PED approval is required, this must be explicitly stated in the order. For devices with nominal diameters less than or equal to DN 25 (1"), this is neither possible nor necessary.</p> <ul style="list-style-type: none"> ■ With the PED/G1/x (x = category) marking on the sensor nameplate, Endress+Hauser confirms compliance with the "Essential Safety Requirements" specified in Annex I of the Pressure Equipment Directive 2014/68/EU. ■ Devices bearing this marking (PED) are suitable for the following types of medium: Media in Group 1 and 2 with a vapor pressure greater than, or smaller and equal to 0.5 bar (7.3 psi) ■ Devices not bearing this marking (PED) are designed and manufactured according to good engineering practice. They meet the requirements of Art.4 Section 3 of the Pressure Equipment Directive 2014/68/EU. The range of application is indicated in tables 6 to 9 in Annex II of the Pressure Equipment Directive 2014/68/EU.

Ordering information

Detailed ordering information is available from the following sources:

- In the Product Configurator on the Endress+Hauser website: www.endress.com → Select country → Instruments → Select device → Product page function: Configure this product
- From your Endress+Hauser Sales Center: www.endress.com/worldwide



Note!

Product Configurator - the tool for individual product configuration

- Up-to-the-minute configuration data
- Depending on the device: Direct input of measuring point-specific information such as measuring range or operating language
- Automatic verification of exclusion criteria
- Automatic creation of the order code and its breakdown in PDF or Excel output format
- Ability to order directly in the Endress+Hauser Online Shop

Accessories

Various accessories, which can be ordered separately from Endress+Hauser, are available for the transmitter and the sensor. Your Endress+Hauser service organization can provide detailed information on the order codes in question.

Documentation

- System Information Promag 10 (SI00042D/06)
- Operating Instructions Promag 10 (BA00082D/06)

Registered trademarks

HART®

Registered trademark of the HART Communication Foundation, Austin, USA

FieldCare®, Fieldcheck®

Registered or registration-pending trademarks of the Endress+Hauser Group