

# Measuring insert for resistance thermometer Model TR10-A

WIKA data sheet TE 60.01



for further approvals  
see page 6

## Applications

- Replacement measuring insert for servicing
- For all industrial and laboratory applications

## Special features

- Application ranges from -200 ... +600 °C  
(-328 ... +1,112 °F)
- Made of mineral-insulated sheathed cable
- Functional safety (SIL) with model T32 temperature transmitter
- Spring-loaded design
- Explosion-protected versions



Fig. left: Standard version

Fig. right: With recessed soldering lugs (option)

## Description

The measuring inserts per DIN 43735 for resistance thermometers described here are designed for installation in a protective fitting. Operation without a thermowell is only advisable in special cases. The measuring insert is manufactured from bendable, mineral-insulated sheathed cable. The sensor is located in the tip of the measuring insert. The measuring inserts are delivered with loading springs to ensure a good contact to the thermowell floor.

Apart from the DIN versions, customer specific versions are available, for example:

- other measuring insert lengths (also intermediate lengths)
- with mounted sleeve to suit inner diameter of the thermowell
- without terminal block
- with transmitter

Type and number of sensors, accuracy and method of connection can each be selected to suit the respective application.

The range of applications is completed by designs without terminal block for direct transmitter installation. Optionally, analogue or digital transmitters from the WIKA range can be installed.







## Explosion protection

The classification/suitability of the instrument (permissible power  $P_{max}$  as well as the permissible ambient temperature) for the respective category can be seen on the EC-type examination certificate, the Ex certificate or in the operating instructions.

### Attention:

Depending on the version, the measuring inserts can be used in “intrinsically safe Ex i” or “non-incendive Ex n” ignition protection types when built into model TR10-B, TR10-C, TR10-F or TR81 resistance thermometers. With the correspondingly suitable protective fitting, operation in dust Ex hazardous areas is possible.

**The use of a model TR10-A measuring insert is not permitted in hazardous areas without a suitable protective housing!**

Explosion protection	Ignition protection type	Zone
ATEX 	Ex i	Zone 1, gas [Ex ia ... Gb]
	Ex n	Zone 2, gas
IECEX (in conjunction with ATEX) 	Ex i	Zone 1, gas [Ex ia ... Gb]
EAC 	Ex i	Zone 1, gas Ex ib IIC T3/T4/T5/T6
	Ex n	Zone 2, gas Ex nA/Ex nL IIC T6 ... T1
NEPSI 	Ex i	Zone 1, gas [Ex ia ... Gb]
	Ex n	Zone 2, gas [Ex nA II T1 ... T6]
KOSHA 	Ex i	Zone 1, gas [Ex ib IIC T4 ... T6]
INMETRO 	Ex i	Zone 1, gas [Ex ia ... Gb]
PESO	Ex i	Zone 1, gas [Ex ia ... Gb]
NAMUR NE24 	Ex i	-

# Sensor

## Measuring element

Pt100 (measuring current: 0.1 ... 1.0 mA) <sup>1)</sup>

Connection method	
Single elements	1 x 2-wire 1 x 3-wire 1 x 4-wire
Dual elements	2 x 2-wire 2 x 3-wire 2 x 4-wire <sup>2)</sup>

Tolerance value of the measuring insert per EN 60751		
Class	Sensor construction	
	Wire-wound	Thin-film
Class B	-200 ... +600 °C	-50 ... +500 °C
Class A <sup>3)</sup>	-100 ... +450 °C	-30 ... +300 °C
Class AA <sup>3)</sup>	-50 ... +250 °C	0 ... 150 °C

1) For detailed specifications for Pt100 sensors, see Technical information IN 00.17 at [www.wika.com](http://www.wika.com).

2) Not with 3 mm diameter

3) Not for 2-wire connection method

## Electrical connection

(Colour code per EN/IEC 60751)

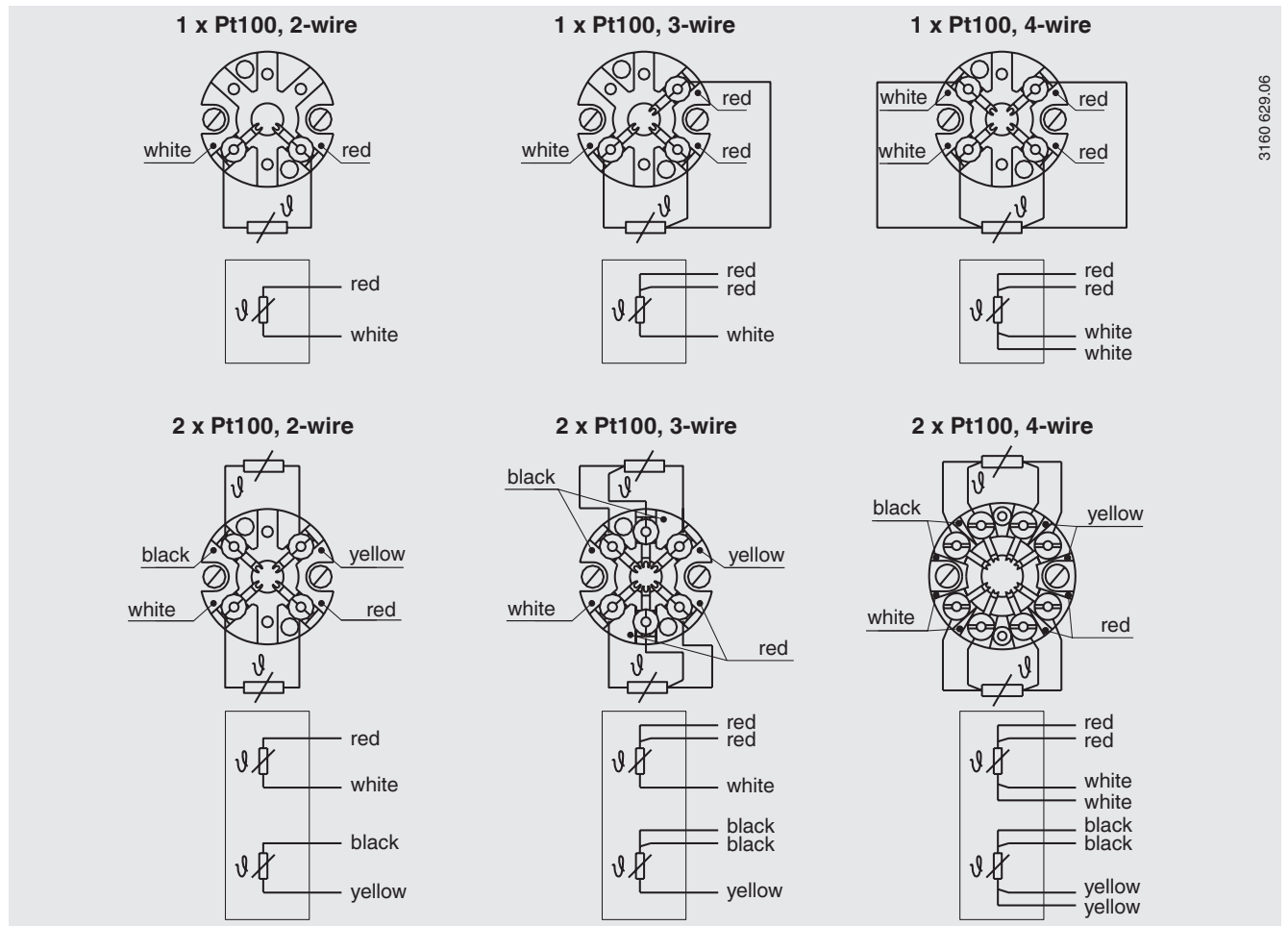

3160 629.06

For the electrical connections of built-in temperature transmitters see the corresponding data sheets or operating instructions.

## Transmitter (option)

A transmitter can be built upon the measuring insert. In this case, the transmitter replaces the terminal block and is directly attached to the terminal plate of the measuring insert. The temperature transmitter should be protected from temperatures over 85 °C.

Output signal 4 ... 20 mA, HART® protocol, FOUNDATION™ fieldbus and PROFIBUS® PA					
Transmitter (selectable versions)	Model T19	Model T24	Model T12	Model T32	Model T53
Data sheet	TE 19.03	TE 24.01	TE 12.03	TE 32.04	TE 53.01
<b>Output</b>					
■ 4 ... 20 mA	x	x	x	x	
■ HART® protocol				x	
■ FOUNDATION™ Fieldbus and PROFIBUS® PA					x
<b>Connection method</b>					
■ 1 x 3-wire	x	x	x	x	x
■ 1 x 4-wire			x	x	x
Measurement current	0.8 mA	0.5 mA	0.2 mA	0.3 mA	0.2 mA

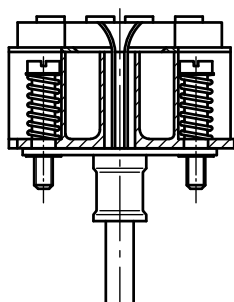

Measuring insert with mounted transmitter  
(here: model T32)

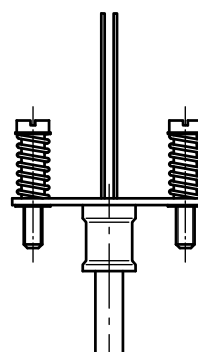

Measuring insert prepared for transmitter mounting

## Functional safety (option) with temperature transmitter model T32



In safety-critical applications, the entire measuring chain must be taken into consideration in terms of the safety parameters. The SIL classification allows the assessment of the risk reduction reached by the safety installations.

Selected TR10-A measuring inserts in combination with a suitable temperature transmitter (e.g. model T32.1S, TÜV certified SIL version for protection systems developed in accordance with IEC 61508) are suitable as sensors for safety functions to SIL 2.

Matched thermowells allow easy dismounting of the measuring insert for calibration. The optimally matched measuring point consists of a thermowell, a thermometer with built-in TR10-A measuring insert and a T32.1S transmitter developed in accordance with IEC 61508. Thus, the measuring point provides maximum reliability and a long service life.

## Dimensions in mm

The replaceable measuring insert is made of a vibration-resistant, sheathed, mineral-insulated cable (MI cable).

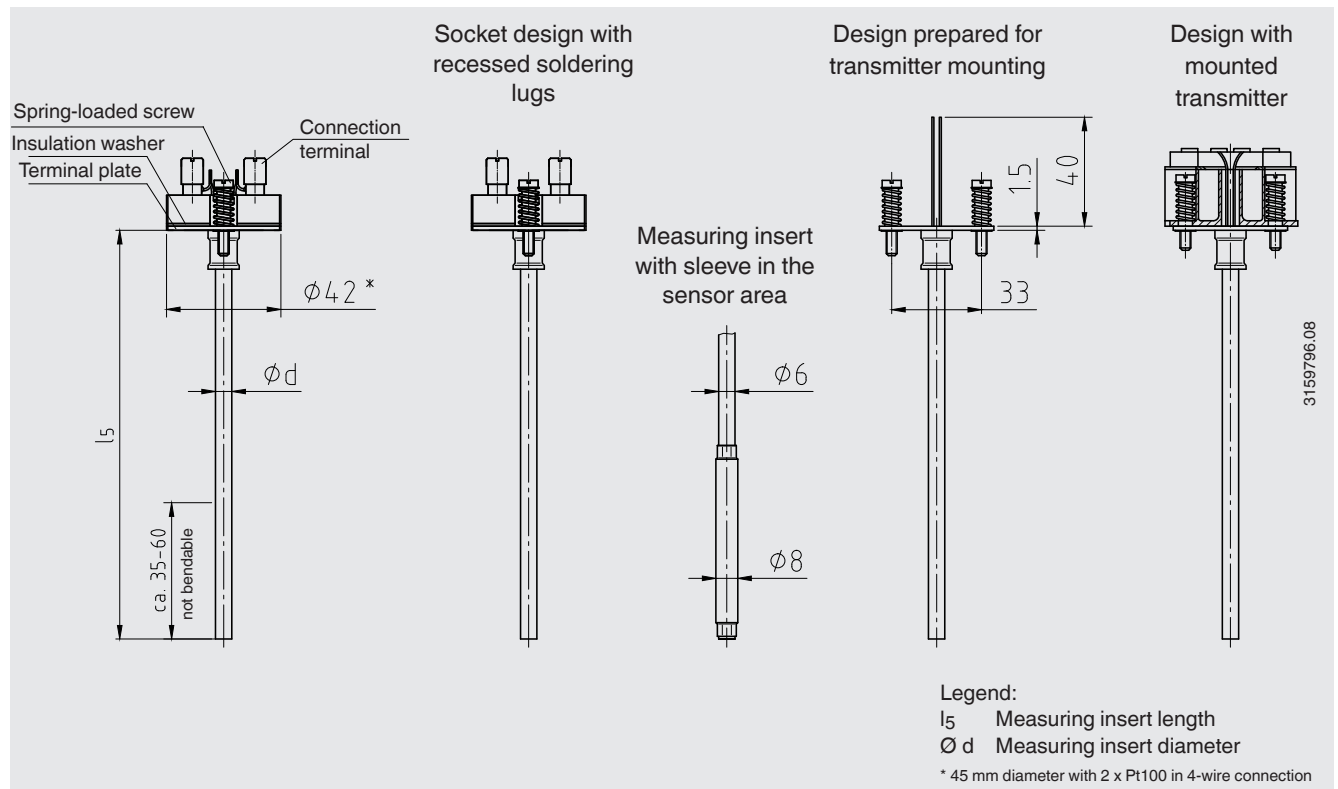

Measuring insert length $l_5$ in mm	Tolerance in mm
75 ... 825	+2 0
> 825	+3 0

Measuring insert diameter $\varnothing d$ in mm		Index per DIN 43735	Tolerance in mm
3 <sup>1)</sup>	Standard	30	3 ±0.05
6	Standard	60	6 <sup>0</sup> -0,1
8 (6 mm with sleeve)	Standard	-	8 <sup>0</sup> -0,1
8	Standard	80	8 <sup>0</sup> -0,1
1/8 inch (3.17 mm) <sup>1)</sup> 1/4 inch (6.35 mm) 3/8 inch (9.53 mm)	Option, on request	-	-

1) Not possible with 2 x Pt100, 4-wire

Only correct measuring insert length and correct measuring insert diameter ensure sufficient heat transfer from thermowell to the measuring insert.

The bore diameter of the thermowell should be a max. 1 mm larger than the measuring insert diameter.

Gaps of more than 0.5 mm between thermowell and the measuring insert will have a negative effect on the heat transfer, and they will result in unfavourable response behaviour from the thermometer.

When fitting the measuring insert into a thermowell, it is very important to determine the correct insertion length (= thermowell length for bottom thicknesses of ≤ 5.5 mm). In order to ensure that the measuring insert is firmly pressed down onto the bottom of the thermowell, the insert must be spring-loaded (spring travel: max 10 mm).

## Materials

Material	
Sheath material	Stainless steel 316 <sup>1)2)</sup>
	Stainless steel 1.4571

## CE conformity

### EMC directive <sup>3)</sup>

2004/108/EC, EN 61326 emission (group 1, class B) and interference immunity (industrial application)

### ATEX directive (option)

94/9/EC

## Approvals (option)

- **IECEX**, international certification for the Ex area
- **NEPSI**, ignition protection type "i" - intrinsic safety, ignition protection type "n", China
- **EAC**, import certificate, customs union Russia/Belarus/Kazakhstan
- **GOST**, metrology/measurement technology, Russia
- **INMETRO**, Institute of Metrology, Brazil
- **KOSHA**, ignition protection type "i" - intrinsic safety, South Korea
- **PESO (CCOE)**, ignition protection type "i" - intrinsic safety, India

## Certificates (option)

Certification type	Measuring accuracy	Material certificate
2.2 test report	x	x
3.1 inspection certificate	x	-
DKD/DAkkS calibration certificate	x	-

The different certifications can be combined with each other.

Approvals and certificates, see website

## Ordering information

Model / Explosion protection / Ignition protection type / Zone / Sensor / Accuracy class / Application range of the thermometer / Measuring insert length  $l_5$  / Measuring insert diameter  $\varnothing d$  / Sheath material / Mechanical requirements / Certificates / Options

© 2003 WIKA Alexander Wiegand SE & Co. KG, all rights reserved.  
The specifications given in this document represent the state of engineering at the time of publishing.  
We reserve the right to make modifications to the specifications and materials.

## Operating conditions

### Mechanical requirements

Version (per EN 60751)	
Standard	6 g, peak-to-peak
Option	Vibration resistant sensor tip, max. 20 g peak-to-peak (thin-film measuring resistor)
	Highly vibration resistant sensor tip, max. 50 g peak-to-peak (thin-film measuring resistor)

The replaceable measuring insert is made of a vibration-resistant, sheathed, mineral-insulated cable (MI cable).

### Response time (in water, per EN 60751)

$t_{50} < 10$  s

$t_{90} < 20$  s

Specifications for measuring insert diameter 6 mm

The thermowell required for operation increases the response time dependent upon the actual parameters for the thermowell and the process.

### Ambient and storage temperature

{-50} -40 ... +80 °C

### Ingress protection

IP 00 per IEC 529/EN 60530

The model TR10-A measuring inserts are designed for mounting into a resistance thermometer.

These resistance thermometers feature connection housings/cable glands/protective fittings which ensure a high IP protection.

{ } Items in curved brackets are available optional extras

1) Not with 2-wire versions

2) Not with socket design with recessed soldering lugs

3) Valid only with built-in transmitters