

Resistance thermometer Model TR30, compact design

WIKA data sheet TE 60.30



for further approvals
see page 8

Applications

- Machine building, plant and vessel construction
- Propulsion technology, hydraulics
- General applications

Special features

- Measuring ranges from -50 ... +250 °C (-58 ... +482 °F), accuracy class per DIN EN 60751
- TR30-W: integrated transmitter, programmable and able to be calibrated via software
- Electrical connection via DIN angular connector or circular connector
- Process connection and sensor tube from stainless steel
- Explosion-protected versions Ex i



Fig. left: with circular connector M12 x 1
Fig. right: with DIN angular connector

Description

Resistance thermometers of this series are used as universal thermometers for the measurement of liquid and gaseous media.

They can be used for pressures up to 40 bar (special designs to 400 bar dependent on insertion length and diameter). All electrical components are protected against splashed water and are designed to withstand vibration.

The TR30 resistance thermometer consists of a sensor tube, which can be fixed into the process using a permanently-welded threaded connection or a compression fitting. A version with no process connection is also available. The electrical connection is made via a DIN angular connector or an M12 x 1 circular connector.

Output signal Pt100

The model TR30-P resistance thermometer is available with a direct Pt100 signal. An intrinsically safe variant can be supplied as an option.

Output signal 4 ... 20 mA

In the model TR30-W resistance thermometer, a software-programmable transmitter with a 4 ... 20 mA output signal is built in. Thus the measured temperature values can be transmitted safely and simply.

The model TR30-W resistance thermometer is available, as an option, in an intrinsically safe variant.

Specifications

Thermometer with direct sensor output with Pt100 output signal, model TR30-P	
Temperature range	
■ Class A	Without neck tube -30 ... +150 °C (-22 ... +302 °F) With neck tube -30 ... +250 °C (-22 ... +482 °F)
■ Class B	Without neck tube -50 ... +150 °C (-58 ... +302 °F) With neck tube -50 ... +250 °C (-58 ... +482 °F)
Measuring element (measuring current: 0.1 ... 1.0 mA)	Pt100 measuring resistor
Connection method	■ 2-wire ■ 3-wire ■ 4-wire
Measuring element tolerance value per IEC 60751	■ Class B ■ Class A
Electrical connection	■ M12 x 1 circular connector (4-pin) ■ DIN angular connector form A for cables with Ø 6 ... 8 mm, cross section max. 1.5 mm ²
Explosion protection (option)	Intrinsically safe to Ex i gas/dust

For detailed specifications for Pt sensors, see Technical information IN 00.17 at www.wika.com.

Thermometer with transmitter and 4 ... 20 mA output signal, model TR30-W	
Temperature range ¹⁾	
■ Class A	Without neck tube -30 ... +150 °C (-22 ... +302 °F) With neck tube -30 ... +250 °C (-22 ... +482 °F)
■ Class B	Without neck tube -50 ... +150 °C (-58 ... +302 °F) With neck tube -50 ... +250 °C (-58 ... +482 °F)
Measuring element (measuring current: 0.5 mA)	Pt100 measuring resistor
Tolerance value of the measuring element ¹⁾ per IEC 60751	■ Class B ■ Class A
Measuring span	Minimum 20 K, maximum 300 K
Basic configuration	Measuring range 0 ... 150 °C, other measuring ranges are adjustable
Analogue output	4 ... 20 mA, 2-wire
Measuring deviation per IEC 60770, 23 °C ±5 K	1 % (Transmitter) ²⁾
Linearisation	Linear to temperature per IEC 60751
Linearisation error	±0.1 % ³⁾
Switch-on delay, electrical	< 10 ms
Current signal for fault signal	Configurable in accordance with NAMUR NE43 downscale ≤ 3.6 mA upscale ≥ 21.0 mA
Sensor short-circuit	Not configurable, generally NAMUR downscale ≤ 3.6 mA
Load R_A	$R_A \leq (U_B - 9 \text{ V}) / 0.023 \text{ A}$ with R _A in Ω and U _B in V
Effect of load	±0.05 % / 100 Ω
Power supply U_B	DC 10 ... 35 V
Max. permissible residual ripple	10 % at 24 V / maximum 300 Ω load
Power supply input	Protected against reverse polarity
Power supply effect	±0.025 % / V
Electromagnetic compatibility (EMC)	EN 61326 emission (group 1, class B) and interference immunity (industrial application) ⁴⁾ , and also per NAMUR NE21
Temperature units	Configurable °C, °F, K
Info data	TAG No., descriptor and message can be stored in transmitter
Configuration and calibration data	Permanently stored in EEPROM
Electrical connection	■ M12 x 1, 4-pin circular connector ■ DIN angular connector form A for cables with Ø 6 ... 8 mm, cross section max. 1.5 mm ²
Explosion protection (option)	Intrinsically safe to Ex i gas/dust Safety-related maximum values for the current loop (+ and - connections): U _i = DC 30 V C _i = 6.2 nF I _i = 120 mA L _i = 110 µH P _i = 800 mW

Readings in % refer to the measuring span

For a correct determination of the overall measuring error, both sensor and transmitter measuring deviations have to be considered.

1) The temperature transmitter should therefore be protected from temperatures over 85 °C (185 °F)

2) For measuring spans smaller than 50 K additional 0.1 K

3) ±0.2 % for measuring ranges with a lower limit less than 0 °C (32 °F)

4) Use resistance thermometers with shielded cable, and ground the shield on at least one end of the lead, if the lines are longer than 30 m or leave the building.

Ambient conditions	
Ambient and storage temperature	-40 ... +85 °C (-40 ... +185 °F) Model TR30-P with DIN angular connector: -40 ... +125 °C (-40 ... +257 °F)
Ingress protection	IP67 per IEC 529 / EN 60529 for circular connector M12 x 1 IP65 per IEC 529 / EN 60529 for DIN angular connector form A The stated ingress protection only applies when plugged in using mating connectors that have the appropriate ingress protection.
Accuracy ⁵⁾	-1 Kelvin
Response time	t ₅₀ < 5 s t ₉₀ < 10 s (for sensor diameter 6 mm)
Materials (case and process connection)	Stainless steel
Vibration resistance	<ul style="list-style-type: none"> ■ 3 g (IEC 60751, standard) ■ 20 g (IEC 60751, special designs, up to a max. insertion length of 160 mm, no compression fittings)

Sensor tube	
Materials	Stainless steel 1.4571 (316Ti)
Process connection (welded / compression fitting) Thread per DIN 3852, form A	<ul style="list-style-type: none"> ■ G ¼ B (not for sensor diameter 8 mm) ■ G ⅜ B ■ G ½ B ■ ¼ NPT (not for sensor diameter 8 mm) ■ ½ NPT ■ without
Sensor insertion lengths	25, 50, 75, 100, 120, 150, 200, 300, 400 or 500 mm (other insertion lengths possible; ask for delivery times)
Sensor diameter	<ul style="list-style-type: none"> ■ 3 mm (only for insertion length 25 mm) ⁶⁾ ■ 6 mm (insertion lengths 50 ... 500 mm) ■ 6 mm, tapered to 3 mm (insertion lengths 50 ... 500 mm) ■ 8 mm (insertion lengths 50 ... 500 mm)

5) Measured at 100 °C (212 °F)

6) The use of a compression fitting is excluded.

Note:

The resistance thermometers of the series TR30 are designed for direct installation into the process. Using it in an additional thermowell makes no sense.

Dimensions in mm

Process connection with parallel threads (or without process connection)

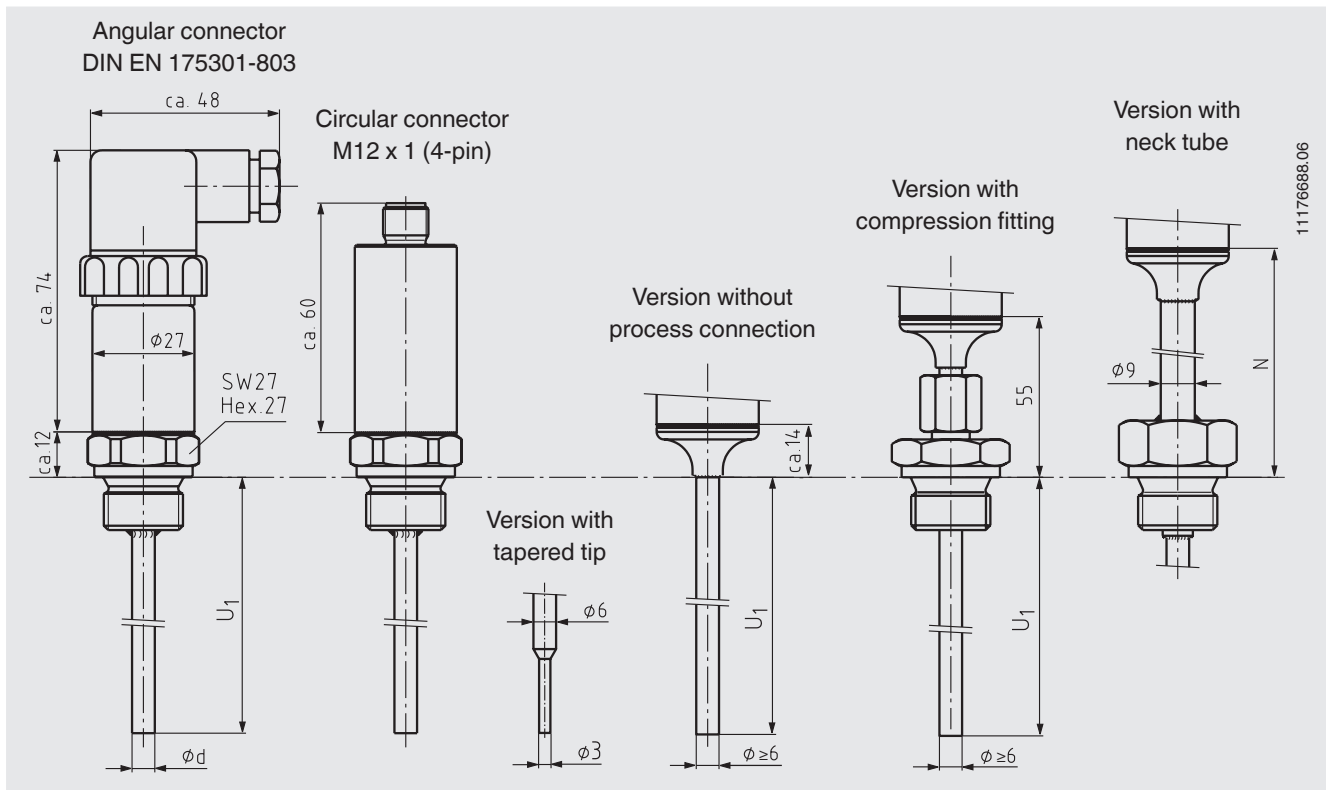

Process connection with tapered threads

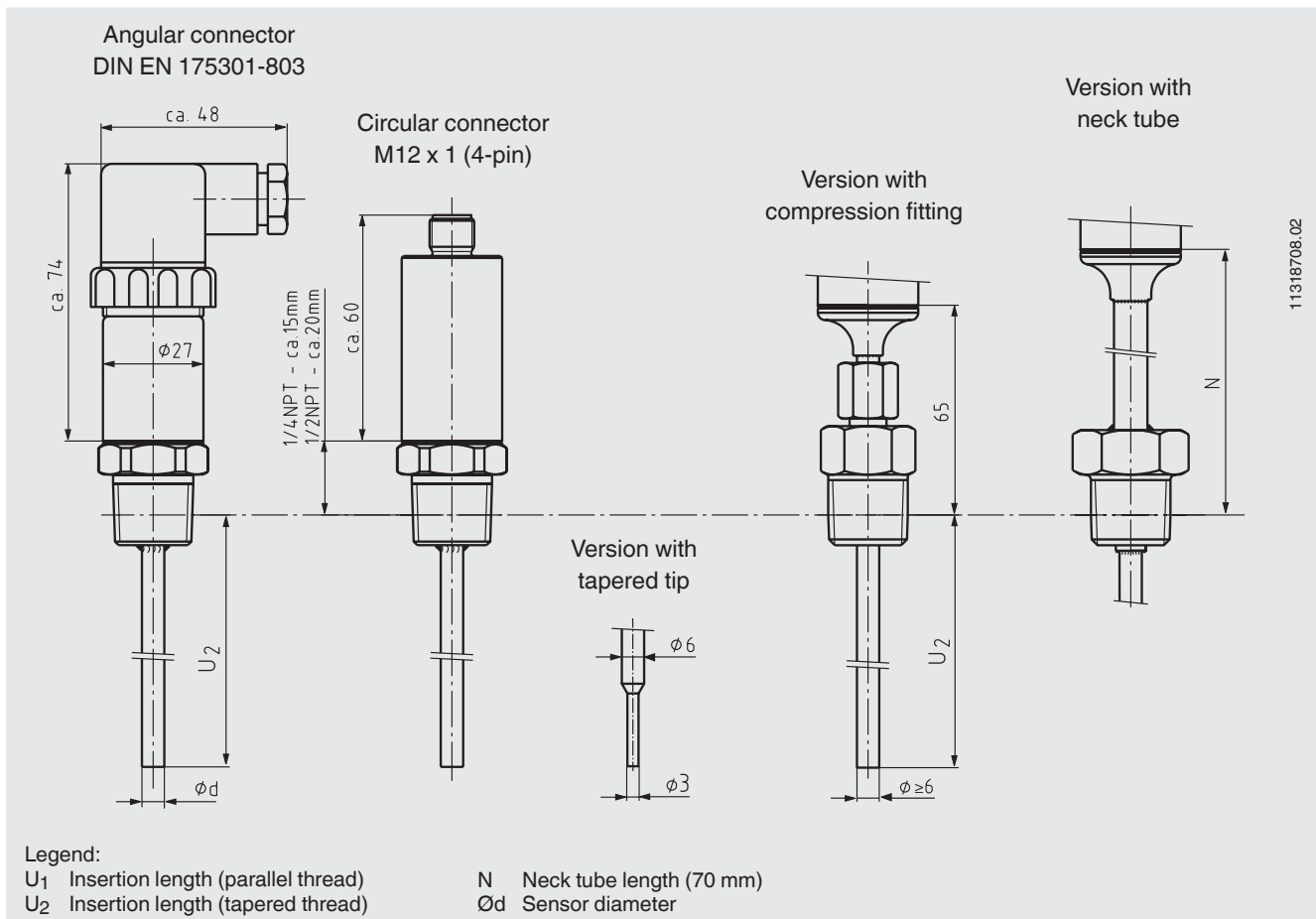

Explosion protection (option)

Resistance thermometers of the TR30 series are available with certificates (NEPSI and EACEx) for the ignition protection type “intrinsic safety” Ex i.

These instruments comply with the requirements for gas and dust.

The classification/suitability of the instrument for the respective category can be seen on the corresponding certificates.

Configuration software WIKAsoft-TT

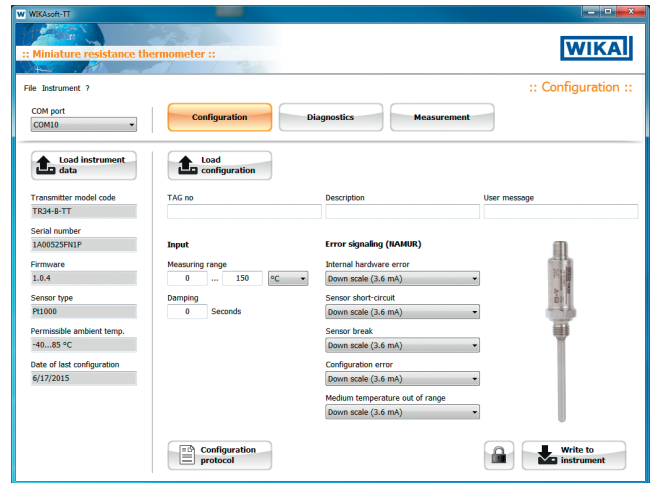

Configuration software (multilingual) as a download from www.wika.com

Accessories

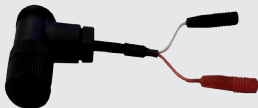
Model	Special features	Order no.
Programming unit model PU-448 	<ul style="list-style-type: none"> ■ Easy to use ■ LED status/diagnostic displays ■ Compact design ■ No further voltage supply is needed for either the programming unit or for the transmitter 	11606304
Adapter cable M12 to PU-448 	Adapter cable for the connection of model TR30-W resistance thermometer to the model PU-448 programming unit	14003193
Adapter cable DIN angular connector to PU-448	Adapter cable of the DIN angular connector for the connection of a model TR30-W resistance thermometer with a DIN EN 175301-803 form A angular connector to the model PU-448 programming unit	14005324

Connecting PU-448 programming unit

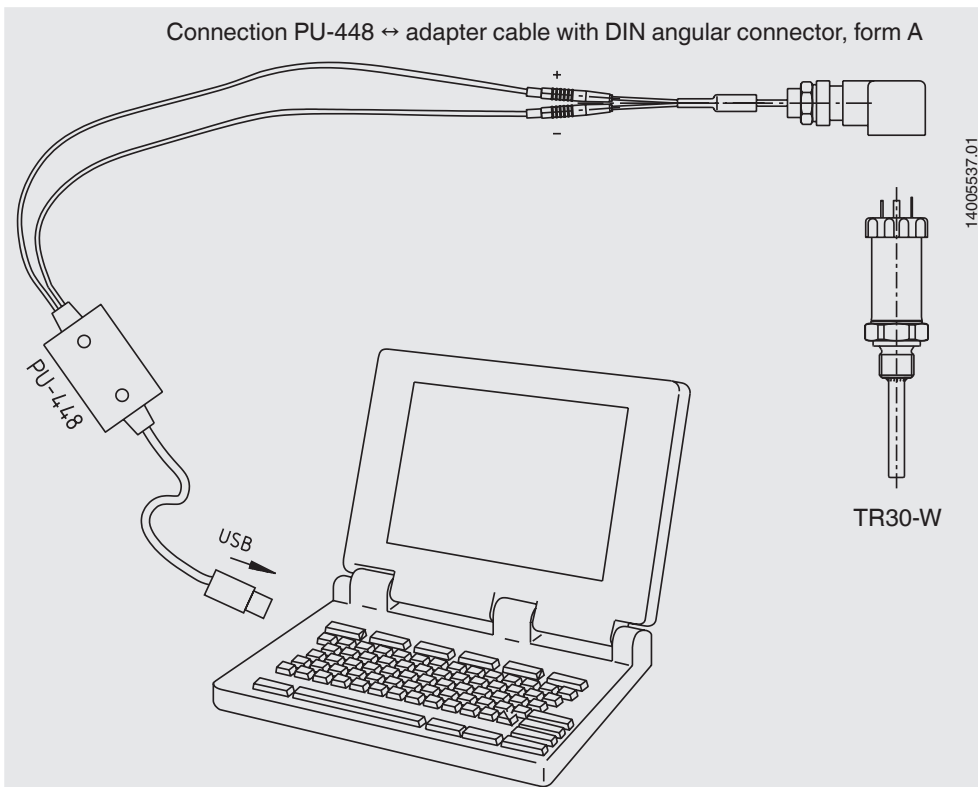
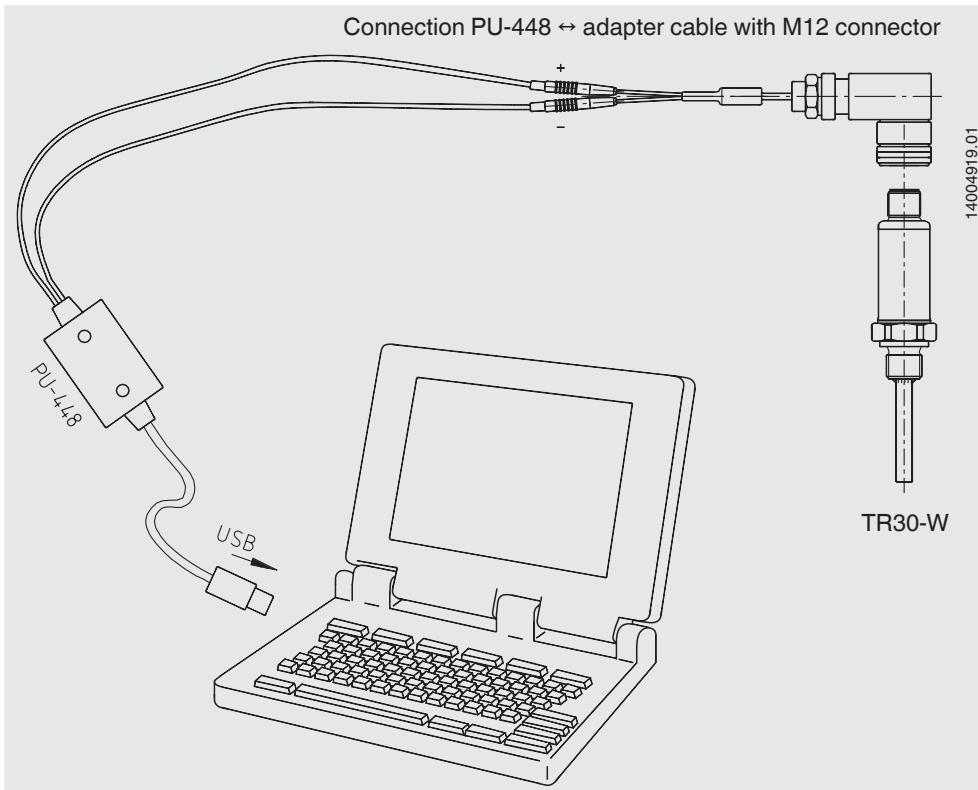

Electrical connection

■ Output signal Pt100, model TR30-P

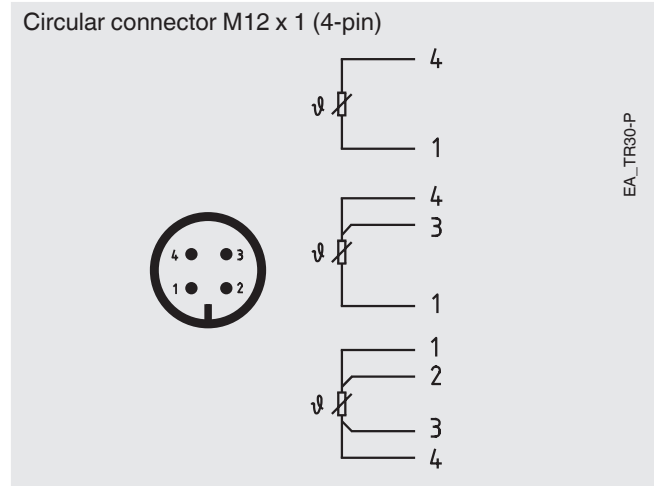
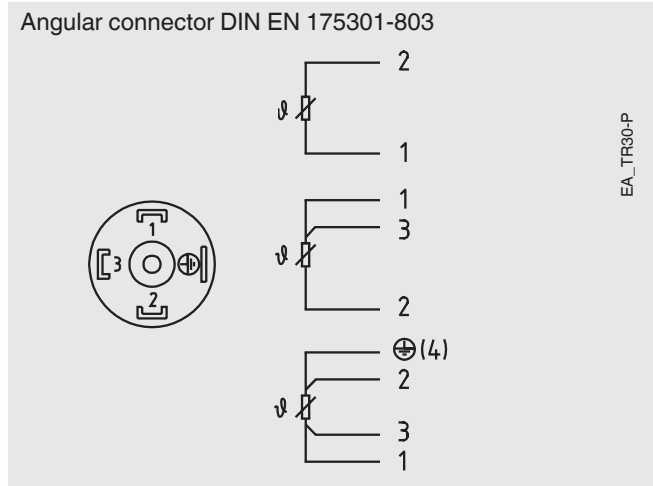

■ Output signal 4 ... 20 mA, model TR30-W

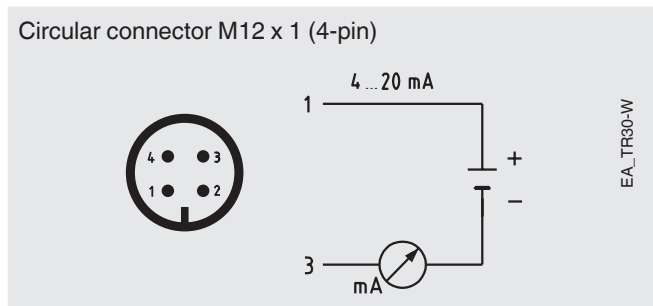
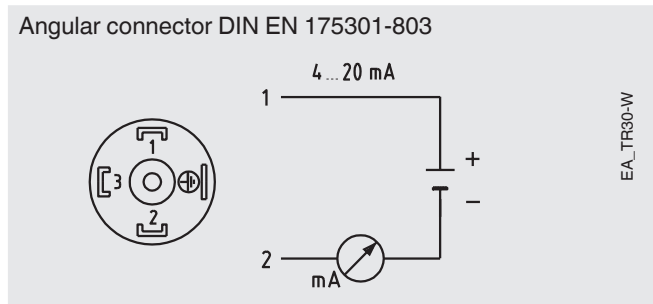





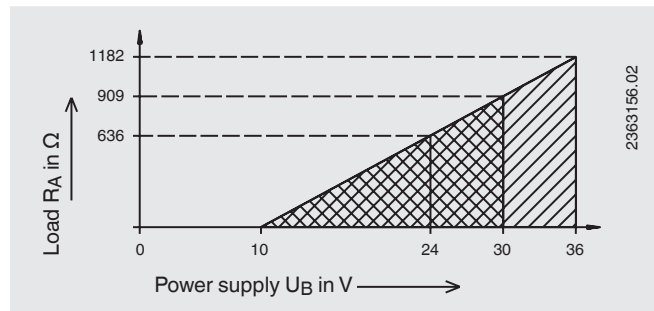

Load diagram for model TR30-W

The permissible load depends on the loop supply voltage.



Approvals

Logo	Description	Country																		
	EU declaration of conformity EMC directive ¹⁾ EN 61326 emission (group 1, class B) and interference immunity (industrial application)	European Community																		
	EAC (option) ■ Electromagnetic compatibility ¹⁾ ■ Hazardous areas 0 Ex ia IIC T6 ... T1 or DIPA21 TA 60 °C/TA 90 °C/TA 120 °C	Eurasian Economic Community																		
	GOST (option) Metrology, measurement technology	Russia																		
	KazInMetr (option) Metrology, measurement technology	Kazakhstan																		
-	MTSCHS (option) Permission for commissioning	Kazakhstan																		
	Uzstandard (option) Metrology, measurement technology	Uzbekistan																		
	NEPSI (option) Hazardous areas II 1G Ex ia IIC T* or II 2D Ex iaD 21 T*	China																		
	DNV (option) ■ Ships, shipbuilding (e.g. offshore) ■ Hazardous areas Location classes:	International																		
	<table border="1"> <thead> <tr> <th>Model</th> <th>Temperature</th> <th>Humidity</th> <th>Vibration</th> <th>EMC</th> <th>Enclosure</th> </tr> </thead> <tbody> <tr> <td>TR30-P</td> <td>D</td> <td>B</td> <td>B</td> <td>-</td> <td>C</td> </tr> <tr> <td>TR30-W</td> <td>D</td> <td>B</td> <td>B</td> <td>A/B ²⁾</td> <td>C</td> </tr> </tbody> </table>	Model	Temperature	Humidity	Vibration	EMC	Enclosure	TR30-P	D	B	B	-	C	TR30-W	D	B	B	A/B ²⁾	C	
Model	Temperature	Humidity	Vibration	EMC	Enclosure															
TR30-P	D	B	B	-	C															
TR30-W	D	B	B	A/B ²⁾	C															

1) Only for built-in transmitter

2) EMC class B when supplied from a dedicated DC 24 V power supply
EMC class A when supplied directly from the ship's distribution board

Certificates (option)

- 2.2 test report
- 3.1 inspection certificate
- DKD/DAkkS calibration certificate

Approvals and certificates, see website

Ordering information

Model / Output signal / Explosion protection / Mechanical tests / Electrical connection / Neck tube / Process connection / Measuring element / Connection method / Temperature range / Transmitter initial value / Transmitter end value / Sensor diameter / Sensor insertion length / Certificates / Options

© 2008 WIKA Alexander Wiegand SE & Co. KG, all rights reserved.
The specifications given in this document represent the state of engineering at the time of publishing.
We reserve the right to make modifications to the specifications and materials.