

Diaphragm pressure switch

For the process industry

Model MW

WIKA data sheet PV 31.10



for further approvals,
see page 6

Process Performance Series

Applications

- Pressure monitoring and control of processes
- Safety-critical applications in general process instrumentation, especially in the chemical and petrochemical industries, oil and gas industries, power generation incl. nuclear power plants, water/wastewater industries, mining
- For gaseous and liquid, aggressive and highly viscous or contaminated media, also in aggressive environments

Special features

- Case from 316L, IP66, NEMA 4X
- Setting ranges from 16 mbar to 600 bar, also all other equivalent vacuum or combined pressure and vacuum ranges
- Intrinsic safety Ex ia available
- 1 or 2 independent switch points, high switching power up to AC 250 V, 20 A
- Switch point repeatability < 1 %

Description

These high-quality mechanical pressure switches have been developed especially for safety-critical applications. The great advantage of mechanical pressure switches is that no supply voltage is required for the switching process.

In production, the switches are traced by quality assurance software at every step and subsequently are 100 % tested. The robust switch enclosure from stainless steel 316L can withstand the rough and corrosive operating conditions of the process industry with working ranges of up to 600 bar. The pressure switch is fitted with 1 or 2 microswitches, which make it possible to switch an electrical load of up to AC 250 V, 20 A directly.

For lower switching power ratings, such as for PLC applications, argon gas-filled microswitches with gold-plated contacts are available.



Fig. left: Model MW with threaded connection
Fig. right: Model MW with flange connection

Depending on the application, the appropriate variant for the contact version and the electrical connection can be selected; e.g. adjustable dead band instead of fixed dead band is often a feature necessary for control processes.

By using a diaphragm measuring system, the model MW pressure switch is extremely robust and guarantees optimal operating characteristics. Flanged process connections are excellently suited for measuring highly viscous, contaminated or crystallising media.

For applications with special requirements on the wetted parts, versions with materials from PTFE, Monel or Hastelloy are available.

For safety applications, the pressure switch is optionally available in a SIL 2-qualified or a SIL 3-qualified version.

Specifications

Basic information	
Version	Diaphragm pressure switch
Special design feature	<ul style="list-style-type: none"> ■ Version for hazardous areas (Ex ia) ■ For oxygen, oil- and grease-free ■ Per NACE ¹⁾ MR0175 / ISO 15156, use in H₂S-containing environments in oil and gas production ■ Per NACE ¹⁾ MR0103 / ISO 17945, metals resistant to sulphide stress cracking ■ Version compliant with EN 1854, pressure sensing devices for gas burners and gas burning appliances ■ Version compliant with EN 12952 and EN 12953, limiting devices in water-tube and shell boilers ■ Drying of wetted parts ■ Offshore version ■ Tropical version (suitable for environments with increased air humidity) ■ Version for ammonia applications ■ Geothermal version ■ Low-temperature version to -60 °C ■ Assembled as a diaphragm seal system ■ Additional protection from stainless steel 316L or Hastelloy for setting ranges 2.5 ... 25 bar ■ Sealing towards the pressure chamber from PTFE/NBR
Contact version	→ See table "Contact version"
Function	<ul style="list-style-type: none"> ■ 1 x SPDT (single pole double throw) ■ 2 x SPDT (single pole double throw) ■ 1 x DPDT (double pole double throw) <p>The DPDT function is realised with 2 simultaneously triggering SPDT microswitches, within 0.2 % of span.</p>
Dead band	<ul style="list-style-type: none"> ■ 1 or 2 contacts with fixed dead band ■ 1 or 2 contacts with adjustable dead band ■ 1 contact with fixed dead band and 1 contact with adjustable dead band
Dielectric strength	Safety class I (IEC 61298-2: 2008)
Switch enclosure	
Design	Case cover with bayonet lock, protection against unauthorised access by lead sealing possible. Laser-engraved product label from stainless steel.
Material	Stainless steel 316L
Mounting ²⁾	<ul style="list-style-type: none"> ■ Direct mounting ■ Wall bracket from stainless steel AISI 304 ■ Mounting bracket for 2" pipe mounting from stainless steel AISI 304

1) General information about NACE standards; see data sheet IN 00.21

2) → See page 8 for permissible mounting positions

Contact version		Electrical rating (resistive load)		Suitable for Ex ia option
		AC	DC	
With fixed dead band				
UN	1 x SPDT, silver	250 V, 15 A	24 V, 2 A, 125 V, 0.5 A, 220 V, 0.25 A	No
US	1 x SPDT, silver, hermetically sealed, argon gas filling ¹⁾	250 V, 15 A	24 V, 2 A, 220 V, 0.5 A	Yes
UO	1 x SPDT, gold-plated, hermetically sealed, argon gas filling ¹⁾	125 V, 1 A	24 V, 0.5 A	Yes
UG	1 x SPDT, gold-plated	125 V, 1 A	24 V, 0.5 A	Yes
DN	2 x SPDT or 1 x DPDT, silver	250 V, 15 A	24 V, 2 A, 125 V, 0.5 A, 220 V, 0.25 A	No
DS	2 x SPDT or 1 x DPDT, silver, hermetically sealed, argon gas filling ¹⁾	250 V, 15 A	24 V, 2 A, 220 V, 0.5 A	Yes

Contact version		Electrical rating (resistive load)		Suitable for Ex ia option
		AC	DC	
DO	2 x SPDT, or 1 x DPDT gold-plated, hermetically sealed, argon gas filling ¹⁾	125 V, 1 A	24 V, 0.5 A	Yes
DG	2 x SPDT or 1 x DPDT, gold-plated	125 V, 1 A	24 V, 0.5 A	Yes
With adjustable dead band				
UR	1 x SPDT, silver	250 V, 20 A	24 V, 2 A, 220 V, 0.5 A	Yes ²⁾
RR ³⁾	2 x SPDT or 1 x DPDT, silver	250 V, 15 A	24 V, 2 A, 220 V, 0.5 A	Yes ²⁾
With fixed dead band and adjustable dead band				
DR ³⁾	2 x SPDT, silver (1 x UN + 1 x UR)	250 V, 15 A	24 V, 2 A, 220 V, 0.5 A	Yes ²⁾

1) Permissible ambient temperature range: -30 ... +70 °C

2) WIKA recommends argon gas-filled contact versions, use of adjustable dead band allowed.

3) Information on switching performance for this contact version on request

Sensor element		Model	Wetted parts		Permissible medium temperature ¹⁾
			Sensor element	Process connection	
Setting range 0 ... 16 mbar to 0 ... 40 bar					
XX ²⁾	Diaphragm element	MWB, MW	Stainless steel 316 ³⁾	Stainless steel 316L	-30 ... +85 °C
TX	Diaphragm element	MWB, MW	Stainless steel 316 ³⁾ + PTFE ⁴⁾	Stainless steel 316L	-30 ... +85 °C
TT	Diaphragm element	MWB, MW	Stainless steel 316 ³⁾ + PTFE ⁴⁾	Stainless steel 316L + PTFE	-30 ... +85 °C
KK ²⁾	Diaphragm element	MWB, MW	Monel ⁵⁾	Monel	-30 ... +85 °C
KX ²⁾	Diaphragm element	MWB, MW	Monel ⁵⁾	Stainless steel 316L	-30 ... +85 °C
Setting range 4 ... 40 bar to 30 ... 600 bar					
GXX ⁶⁾	Piston with welded diaphragm element	MWG	Hastelloy C276	Stainless steel 316L	-40 ... +85 °C
HXX ⁷⁾	Piston with O-ring sealing from FPM	MWH	Stainless steel 316	Stainless steel 316L	0 ... 85 °C
	Piston with O-ring sealing from NBR	MWH	Stainless steel 316	Stainless steel 316L	-10 ... +85 °C

1) Permissible medium temperature range in the main process line. Depending on the measuring assembly, this may differ from the permissible temperature at the process connection. For further information, see operating instructions.

2) Standard sealing: Model MWB with O-Ring from PTFE and model MW with O-Ring from FPM

3) Other diaphragm element material depending on setting range: Stainless steel 304: -1 ... 5, 0 ... 6, -1 ... 9, 0 ... 10 bar; Inconel 718: -1 ... 15, 0 ... 16, 0 ... 25, 0 ... 40 bar

4) PTFE coating is not available for all setting ranges → See table "Setting range"

5) Only for setting ranges ≤ 10 bar

6) Particularly suited for gaseous media

7) Particularly suited for liquid media

Other materials for wetted parts on request

Accuracy specifications	
Set point repeatability	≤ 1 % of span of setting range
Dead band	→ See table "Setting range"

Setting range for model MWB								
Span of setting range from 16 mbar to max. 100 mbar								
Standard		Variant 1		Variant 2		Dead band		
Setting range (= working range)	Proof pressure	Working range	Proof pressure	Working range	Proof pressure	1 contact, fixed	2 contacts, fixed	1 contact, adjustable
in mbar		in bar	in bar	in bar	in bar	in mbar	in mbar	in mbar
0 ... 16	250	0 ... 8	10	-1 ... 8 ¹⁾	10	≤ 2.0	≤ 2.8	-
0 ... 25	250	0 ... 8	10	-1 ... 8 ¹⁾	10	≤ 2.0	≤ 3	8 ... 18
0 ... 40	300	0 ... 8	10	-1 ... 8 ¹⁾	10	≤ 2.6	≤ 3.4	8 ... 20

Setting range for model MWB Span of setting range from 16 mbar to max. 100 mbar								
Standard		Variant 1		Variant 2		Dead band		
Setting range (= working range)	Proof pressure	Working range	Proof pressure	Working range	Proof pressure	1 contact, fixed	2 contacts, fixed	1 contact, adjustable
in mbar		in bar	in bar	in bar	in bar	in mbar	in mbar	in mbar
0 ... 60	300	0 ... 8	10	-1 ... 8 ¹⁾	10	≤ 3.0	≤ 4.2	12 ... 25
0 ... 100	600	0 ... 8	10	-1 ... 8 ¹⁾	10	≤ 3.6	≤ 5	17 ... 40
-16 ... 0	-21	-1 ... 0 ¹⁾	0.25	-	-	≤ 2.0	≤ 2.8	-
-25 ... 0	-35	-1 ... 0 ¹⁾	0.25	-	-	≤ 2.0	≤ 3	8 ... 18
-40 ... 0	-55	-1 ... 0 ¹⁾	0.30	-	-	≤ 2.6	≤ 3.4	8 ... 20
-60 ... 0	-90	-1 ... 0 ¹⁾	0.30	-	-	≤ 3.0	≤ 4.2	12 ... 25
-100 ... 0	-150	-1 ... 0 ¹⁾	0.40	-	-	≤ 3.6	≤ 5	17 ... 40
-12.5 ... +12.5	-25 / 250	-	-	-	-	≤ 2.0	≤ 3	8 ... 18
-30 ... +30	-60 / 250	-	-	-	-	≤ 3.0	≤ 4.2	12 ... 25
-50 ... +50	-100 / 250	-	-	-	-	≤ 3.6	≤ 5	17 ... 40

1) Diaphragm element with PTFE coating is not available

2) Proof pressure of 100 bar not available for wetted parts from PTFE and Monel

Setting range for model MW Span of setting range from 0.2 bar to max. 40 bar								
Standard		Variant 1		Variant 2		Dead band		
Setting range (= working range)	Proof pressure	Working range	Proof pressure	Working range	Proof pressure	1 contact, fixed	2 contacts, fixed	1 contact, adjustable
in bar		in bar	in bar	in bar	in bar	in mbar	in mbar	in mbar
0 ... 0.2	0.4	0 ... 32	40	-1 ... 32 ¹⁾	40	≤ 10	≤ 13	30 ... 70
0 ... 0.4	1	0 ... 32	40	-1 ... 32 ¹⁾	40	≤ 15	≤ 20	40 ... 95
-0.2 ... 0	-0.3	-1 ... 0 ¹⁾	-1	-1 ... 8	10	≤ 10	≤ 13	30 ... 70
-0.4 ... 0	-0.6	-1 ... 0 ¹⁾	-1	-1 ... 8	10	≤ 15	≤ 20	40 ... 95
-0.1 ... + 0.1	-0.2 / 1	-	-	-	-	≤ 10	≤ 13	30 ... 70
-0.5 ... 0.5	-1 / 4	-	-	-	-	≤ 15	≤ 50	75 ... 170
-1 ... 0	-1	-1 ... 8	10	-	-	≤ 15	≤ 50	75 ... 170
-1 ... 1.5	2	-1 ... 8	10	-	-	≤ 48	≤ 67	200 ... 500
-1 ... 5	12	-1 ... 32	40	-1 ... 80	100 ²⁾	≤ 100	≤ 160	400 ... 1,000
-1 ... 9	20	-1 ... 32	40	-1 ... 80	100 ²⁾	≤ 100	≤ 180	600 ... 1,400
-1 ... 15	25	-1 ... 32	40	-1 ... 80	100 ²⁾	≤ 150	≤ 250	1,000 ... 2,400
0 ... 1	4	0 ... 32	40	-1 ... 32	40	≤ 15	≤ 50	75 ... 170
0 ... 1.2	4	0 ... 32	40	-1 ... 32	40	≤ 15	≤ 50	75 ... 170
0 ... 2.5	5	0 ... 32	40	-1 ... 80	100 ²⁾	≤ 48	≤ 67	200 ... 500
0 ... 6	12	-1 ... 32	40	-1 ... 80	100 ²⁾	≤ 100	≤ 160	400 ... 1,000
0 ... 10	20	-1 ... 32	40	-1 ... 80	100 ²⁾	≤ 100	≤ 180	600 ... 1,400
0 ... 16	25	-1 ... 32	40	-1 ... 80	100 ²⁾	≤ 150	≤ 250	1,000 ... 2,400
0 ... 25	40	-1 ... 32	40	-1 ... 80	100 ²⁾	≤ 300	≤ 450	1,700 ... 4,000
0 ... 40	50	-	-	-	-	≤ 400	≤ 800	2,200 ... 5,800

1) Diaphragm element with PTFE coating is not available

2) Proof pressure of 100 bar not available for wetted parts from PTFE and Monel

Setting range for models MWG and MWH Setting range to 600 bar				
Standard		Dead band		
Setting range (= working range)	Proof pressure	1 contact, fixed	2 contacts, fixed	1 contact, adjustable ¹⁾
in bar		in bar	in bar	in bar
4 ... 40	100	≤ 3	≤ 4	5 ... 11 to 8 ... 15
10 ... 100	200	≤ 4	≤ 6	10 ... 22 to 15 ... 28
10 ... 250	400	≤ 10	≤ 13	15 ... 38 to 27 ... 55
20 ... 400	600	≤ 10	≤ 25	35 ... 80 to 43 ... 90
30 ... 600	700	≤ 20	≤ 25	45 ... 105 to 83 ... 155

1) The adjustable dead band is depending on the switch point setting. The indicated ranges are valid for start and end of the setting range. Other setting ranges are proportional.

Distance between set points

For versions with 2 x SPDT the distance between the set points must be > 5 % of the respective span.

Set point adjustment

The set point can be specified by the customer or factory-set within the setting range.

After unscrewing the cover, set point adjustment can be made using the adjustment screw, which is fastened to the switch and thus secured against loss.

The set point (SP) and the switching direction need to be specified (e.g. SP1: 0.5 bar falling and SP2: 3 bar rising).

The set point is selectable within the entire setting range. For optimal performance we suggest to adjust the set point between 25 ... 75 % of the setting range. In the following example, the maximum possible setting range is shown to be dependent upon the switching direction.

Example

Setting range: 0 ... 1 bar with one switch contact

Repeatability: 1 % of 1 bar = 10 mbar

Dead band: ≤ 15 mbar → See table "Setting range"

Non-settable range: 2 x repeatability + dead band = 2 x 10 mbar + 15 mbar = 35 mbar

Rising pressure: Set point can be adjusted between 35 ... 1,000 mbar

Falling pressure: Set point can be adjusted between 0 ... 965 mbar

→ See operating instructions for further details.

Process connection	
Standard	<ul style="list-style-type: none"> ■ ANSI/ASME B1.20.1 ■ DIN EN ISO 228 ■ ASME B16.5¹⁾ ■ EN 1092-1¹⁾
Size	
ANSI/ASME B1.20.1	<ul style="list-style-type: none"> ■ ¼ NPT, female thread ■ ½ NPT, female thread via adapter ■ ½ NPT, male thread via adapter
DIN EN ISO 228	<ul style="list-style-type: none"> ■ G ¼, female thread via adapter ■ G ½ A, male thread via adapter ■ G ¾ A, male thread via adapter
ASME B16.5 ¹⁾	Flange variant "S" : With fixed stud bolts and included nuts and washers Flange variant "T" : With through-holes and extension pipe → See dimensions from page 9
EN 1092-1 ¹⁾	
Material (wetted)	
Sensor element	Depending on the selected sensor element → See table "Sensor element"
Process connection	
Sealing	PTFE, FPM, NBR, without sealing: welded diaphragm element, depending on setting range and operating conditions. → See table "Setting range"

1) Only available for models MWB and MW

Other process connections on request

Electrical connection	
Connection type	<ul style="list-style-type: none"> ■ Female thread ½ NPT ■ Female thread M20 x 1.5 ■ Female thread ¾ NPT, G ½, G ¾, M 20 x 1.5 ■ Cable gland non-armoured, nickel-plated brass ■ Cable gland non-armoured, stainless steel (AISI 304) ■ Cable gland armoured, nickel-plated brass ■ Cable gland armoured, stainless steel (AISI 304) ■ MIL connector, 7-pin, DTL 5015
Wire cross-section	<p>Use 0.5 ... 1.5 mm² (20 ... 16 AWG) for internal terminal block (also suitable for cable lugs).</p> <p>For the grounding cable connection to the protective conductor use max. 4 mm² for the internal and external screw.</p>
Pin assignment	<p>Connection details are given on the product label of the instrument.</p> <p>Connection terminals and the ground terminal are appropriately marked.</p>





Operating conditions	
Medium temperature range	Depending on sensor element and sealing → See table "Sensor element"
Ambient temperature range	T6/T85°C T _a -60 ... +60 °C
	T4/T135°C T _a -60 ... +85 °C
	Non-Ex versions ■ -40 ... +85 °C ■ -60 ... +85 °C
Ingress protection of the complete instrument	IP66 per EN/IEC 60529 (NEMA 4X)
Weight	Approx. 1.0 kg for models MW, MWG, MWH Approx. 1.5 kg for model MWB

Approvals

Logo	Description	Region
	EU declaration of conformity	European Union
	Pressure equipment directive PED, annex 1, category IV, safety accessories, module B + D	
	Low voltage directive	
	RoHS directive	

Optional approvals

Logo	Description	Region
 	EU declaration of conformity	European Union
	ATEX directive ¹⁾ I M 1 II 1 GD	
 	IECEx ¹⁾ Ex ia I Ma Ex ia IIC T6/T4 ²⁾ Ga Ex ia IIIC T85°C/T135°C ²⁾ Da IP66	International

Logo	Description	Region
	UKCA	United Kingdom
	Pressure equipment (safety) regulations	
	Electrical equipment designed for use within certain voltage limits in support of the electrical equipment (safety) regulations	
	Restriction of hazardous substances (RoHS) regulations	
	Equipment and protective systems intended for use in potentially explosive atmospheres regulations ¹⁾	
	EAC	Eurasian Economic Community
	Low voltage directive (applies only for non-Ex versions)	
	Hazardous areas ¹⁾	
	Ex Ukraine Hazardous areas ¹⁾	Ukraine
	CCC Hazardous areas ¹⁾	China
	KCs Hazardous areas ¹⁾	South Korea
-	ECAS Hazardous areas ¹⁾	United Arab Emirates

1) Double marking ATEX and IECEx on the same product label. Country-specific Ex marking according to selected option.
2) The temperature class is related to the ambient temperature range

Manufacturer's information and certificates

Logo	Description
	SIL 3-capable (option) Functional safety per IEC 61508 Contains performance level calculation per ISO 13849-1

Certificates (option)

Certificates	
Certificates	<ul style="list-style-type: none"> ■ 2.2 test report per EN 10204 (e.g. state-of-the-art manufacturing, indication accuracy) ■ 3.1 inspection certificate per EN 10204 (e.g. indication accuracy)
Recommended calibration interval	1 year (dependent on conditions of use)

→ For approvals and certificates, see website

Safety-related characteristic values (only for Ex version)

Safety-related characteristic values (Ex)	
Voltage	U _i = DC 30 V
Current	I _i = 100 mA
Power	P _i = 750 mW
Effective internal capacitance	C _i = 0 µF
Effective internal inductance	L _i = 0 mH

Dimensions in mm [in]

Model MWB

Span of setting range from 16 mbar to max. 100 mbar

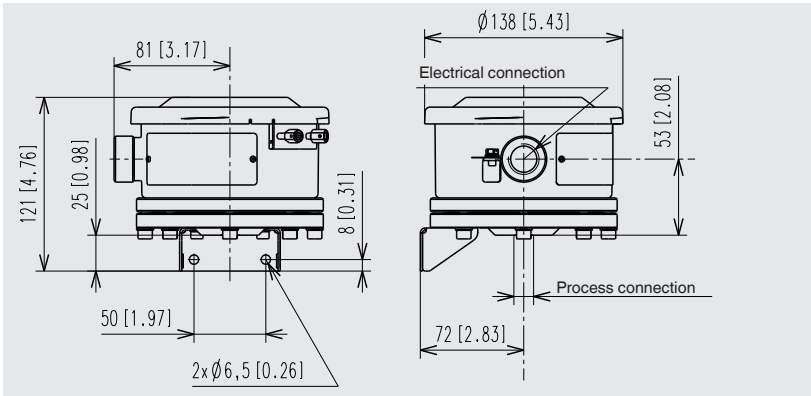

Models MW, MWG, MWH

Span of setting range from 0.2 bar to max. 600 bar

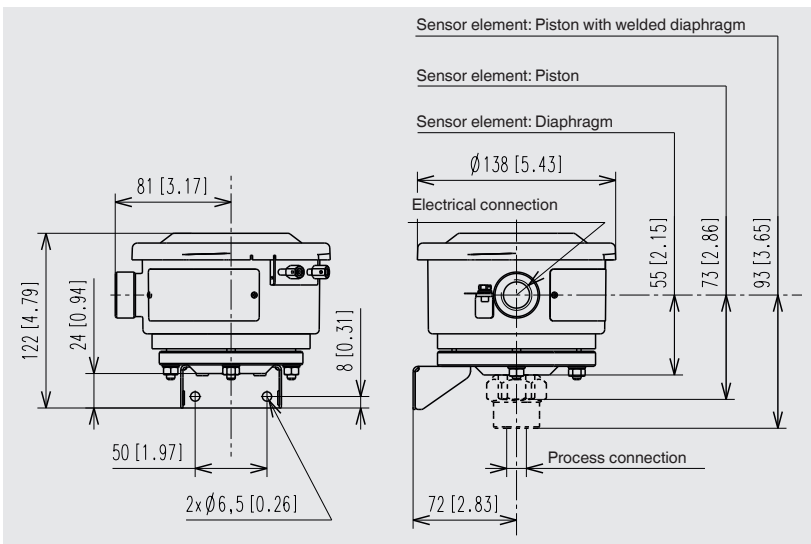

Permissible mounting positions

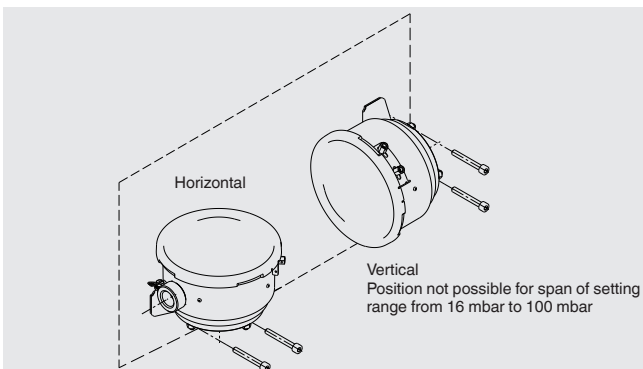

With affixed lead seal

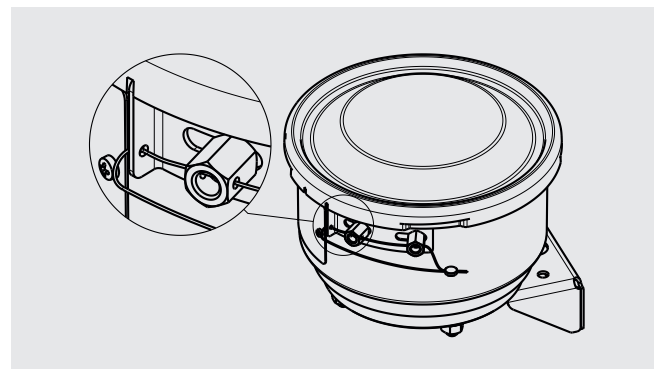

Models MWB and MW, flange variant "S"
Span of setting range from 16 mbar to max. 40 bar

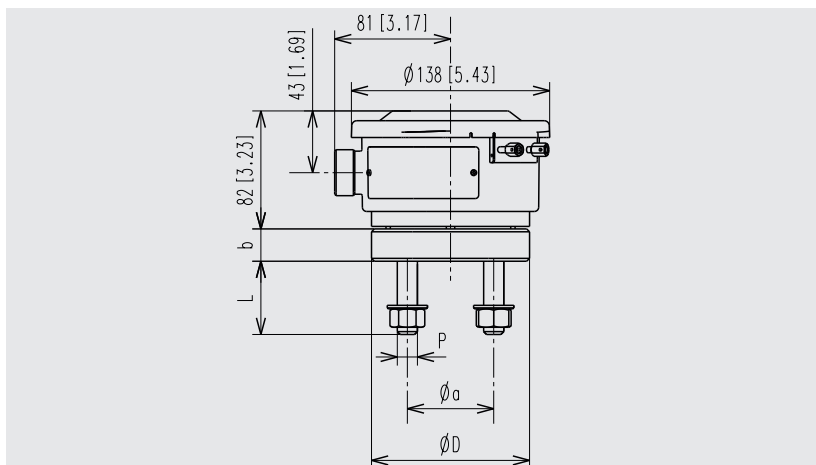

Flange variant "S" has fixed metric stud bolts and the delivery includes nuts and washers.

Material

Stud bolts: ASTM A193-B7 zinc-plated Fe/Zn 8c2C

Nuts: ASTM A194-2H zinc-plated Fe/Zn 8c2C

Flange connection per ASME B 16.5, FF or RF

DN	Class	Dimensions in mm [in]				
		D	b	a	P	L
½"	150	110 [43,31]	25 [9,84]	60,3 [23,74]	4 x M14	51 [20,08]
	300	110 [43,31]	25 [9,84]	66,7 [26,26]	4 x M14	51 [20,08]
¾"	150	110 [43,31]	25 [9,84]	69,8 [27,48]	4 x M14	51 [20,08]
1"	150	110 [43,31]	25 [9,84]	79,4 [31,26]	4 x M14	51 [20,08]
	300	150 [59,06]	25 [9,84]	88,9 [35]	4 x M16	54 [21,26]
1 ½"	150	150 [59,06]	25 [9,84]	98,4 [38,74]	4 x M14	51 [20,08]
	300	150 [59,06]	25 [9,84]	114,3 [45]	4 x M20	60 [23,62]
2"	150	150 [59,06]	25 [9,84]	120,6 [47,48]	4 x M16	54 [21,26]
	300	165 [64,96]	22 [8,66]	127 [50]	8 x M16	54 [21,26]

Flange connection per EN 1092-1, form A or B1

DN	PN	Dimensions in mm [in]				
		D	b	a	P	L
15	10/40	110 [43,31]	25 [9,84]	65 [25,59]	4 x M12	48 [18,9]
20	10/40	110 [43,31]	25 [9,84]	75 [29,53]	4 x M12	48 [18,9]
25	10/40	110 [43,31]	25 [9,84]	85 [33,46]	4 x M12	48 [18,9]
40	10/40	150 [59,06]	25 [9,84]	110 [43,31]	4 x M16	54 [21,26]

Note: The maximum pressure limitation of the pressure switch is the lower value between proof pressure and flange pressure rating.

Models MWB and MW, flange variant "T"
Span of setting range from 16 mbar to max. 40 bar

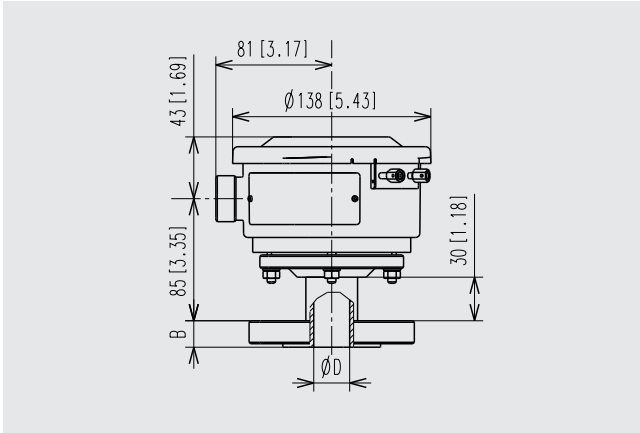

Flange variant "T" has an extension pipe to allow mounting the standard flange connections.

Flange connection per ASME B 16.5, FF, RF or RJ







DN	Class	Dimensions in mm [in]			D
		B			
		FF	RF	RJ	
½"	300	12,6 [4,96]	14,2 [5,59]	-	12 [4,72]
	600	-	20,6 [8,11]	19,8 [7,8]	12 [4,72]
¾"	150	11,2 [4,41]	12,8 [5,04]	-	12 [4,72]
	300	14,3 [5,63]	15,9 [6,26]	-	11 [4,33]
	600	-	22,1 [8,7]	22,1 [8,7]	11 [4,33]
1"	150	12,6 [4,96]	14,2 [5,59]	-	11 [4,33]
	300	15,9 [6,26]	17,5 [6,89]	-	11 [4,33]
	600	-	23,9 [9,41]	23,9 [9,41]	11 [4,33]
1 ½"	150	15,9 [6,26]	17,5 [6,89]	-	26,7 [10,51]
	300	19,1 [7,52]	20,7 [8,15]	-	26,7 [10,51]
	600	-	28,7 [11,3]	28,7 [11,3]	26,7 [10,51]
2"	150	17,5 [6,89]	19,1 [7,52]	-	26,7 [10,51]
	300	20,7 [8,15]	22,3 [8,78]	-	26,7 [10,51]
	600	-	31,7 [12,48]	32,2 [12,68]	26,7 [10,51]

Flange connection per EN 1092-1, form A or B1

DN	PN	Dimensions in mm [in]		D
		B		
		Form A	Form B1	
20	10/40	18 [7,09]	18 [7,09]	16 [6,3]
25	10/40	18 [7,09]	18 [7,09]	25 [9,84]
40	10/40	-	18 [7,09]	25 [9,84]

Note: The maximum pressure limitation of the pressure switch is the lower value between proof pressure and flange pressure rating.

Accessories and spare parts

Model	Description
	910.15 Syphons → See data sheet AC 09.06
	910.13 Overpressure protector → See data sheet AC 09.04
	IV10, IV11 Needle valve and multiport valve → See data sheet AC 09.22
	IV20, IV21 Block-and-bleed valve → See data sheet AC 09.19
	IVM Monoflange, process and instrument version → See data sheet AC 09.17
	BV Ball valve, process and instrument version → See data sheet AC 09.28

Ordering information

Model / Unit / Setting range of set point / Contact version / Process connection / Electrical connection / Wetted parts / Options

© 12/2010 WIKA Alexander Wiegand SE & Co. KG, all rights reserved.
 The specifications given in this document represent the state of engineering at the time of publishing.
 We reserve the right to make modifications to the specifications and materials.